

TAKE A *Giant*[®]
STEP FORWARD,
HELP STOP
THE GREENHOUSE
EFFECT



Eco-friendly
foam insulation
unique to Giant
No HCFC's
No CFC'S
No VOC'S



LIGHT DUTY COMMERCIAL GAS WATER HEATERS

Available in
73 gallon capacity

**BUILT
TO LAST
LONGER**



The following outstanding technical features are why Giant water heaters are “BUILT TO LAST LONGER”.

1- AUTOMATIC TEMPERATURE CONTROL

A justable thermostat will provide years of reliable trouble-free service at desired water temperature and an energy cut-off (E.C.O.) is provided for abnormal conditions.

2- INSULATION

A two (2) inch thick uniform blanket of **GREENFOAM** eco-friendly insulation keeps the water hotter for longer periods, reduces stand-by losses and energy costs. **GREENFOAM** contains no HCFC'S (hydrochlorofluorocarbons), no CFC'S (chlorofluorocarbons) nor VOC's (volatile organic compounds).

3- GLASS LINED INNER TANK

A uniquely formulated blue cobalt glass enriched with zircon is fused to specially treated steel at 1,600°F (871°C) to provide the best coating available against corrosion for many years. The tank is certified at a test pressure of 300 PSI (2,068 kPa) and a working pressure of 150 PSI (1,034 kPa).

4- FACTORY INSTALLED 3/4" NPT DI-ELECTRIC NIPPLES

Extend the life of the water heater by providing excellent corrosion protection.

5- SIDE TAPPINGS

Provide a wider range of installation options. All models are approved for combination potable water and space heating.

NOTE : Toxic chemicals, such as those used for boiler treatment, must NEVER be introduced into this system. These units must NEVER be connected to any existing heating system or component(s) previously used with a non-potable water heating appliance.

6- FACTORY INSTALLED T&P RELIEF VALVE

Protects the tank from the damaging effects of excessive temperature and pressure.

7- DUAL HIGH QUALITY MAGNESIUM ANODES

Provide excellent protection against the corrosive effects of water and extend tank life.

8- DRAIN VALVE

Excellent quality one-piece brass drain valve is installed for easy drainage.

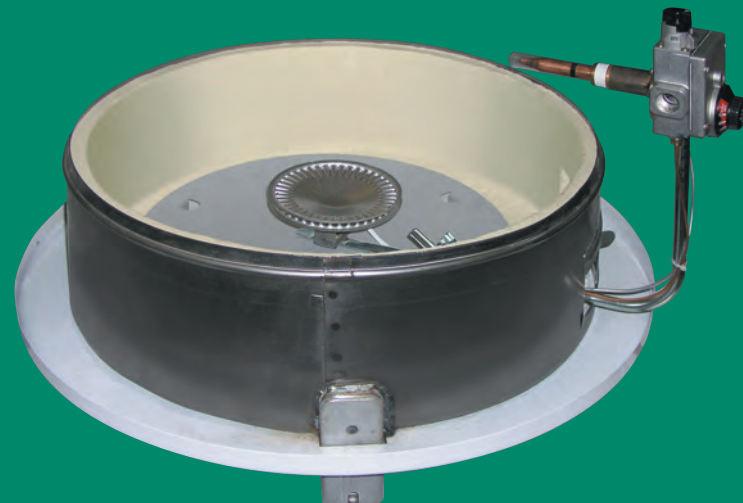
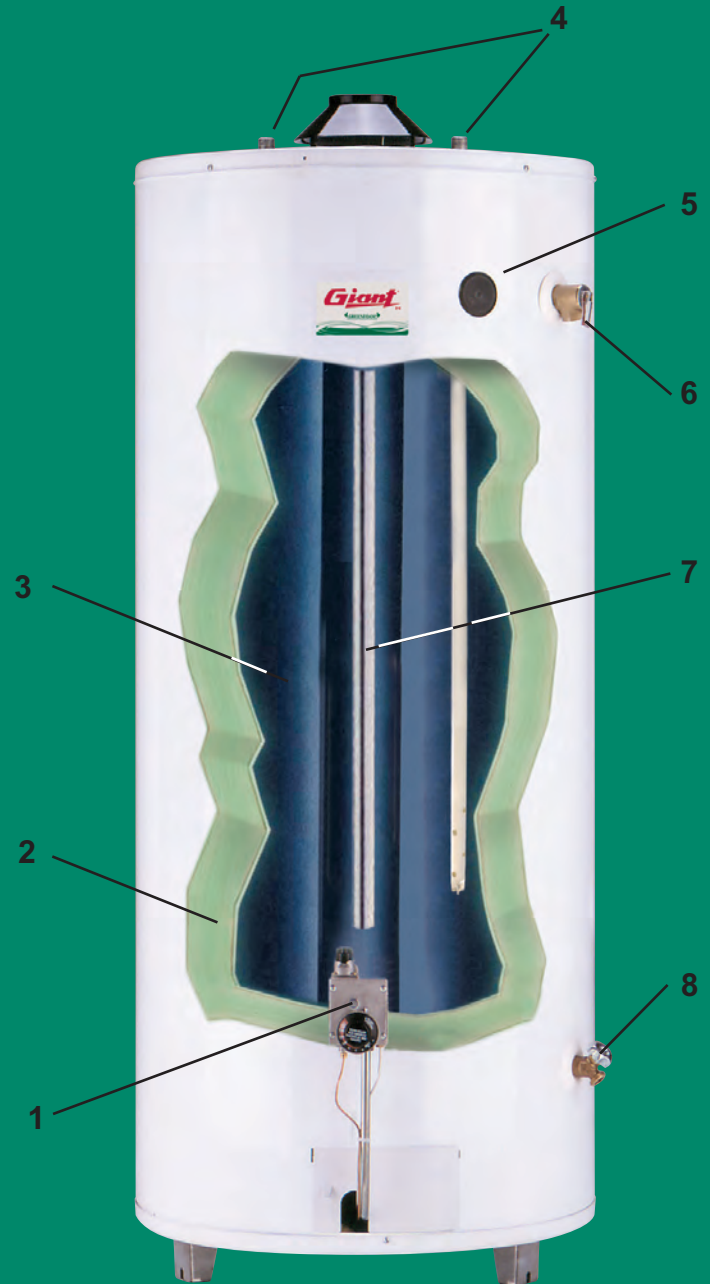

HIGH PERFORMANCE LIGHT DUTY COMMERCIAL GAS WATER HEATERS

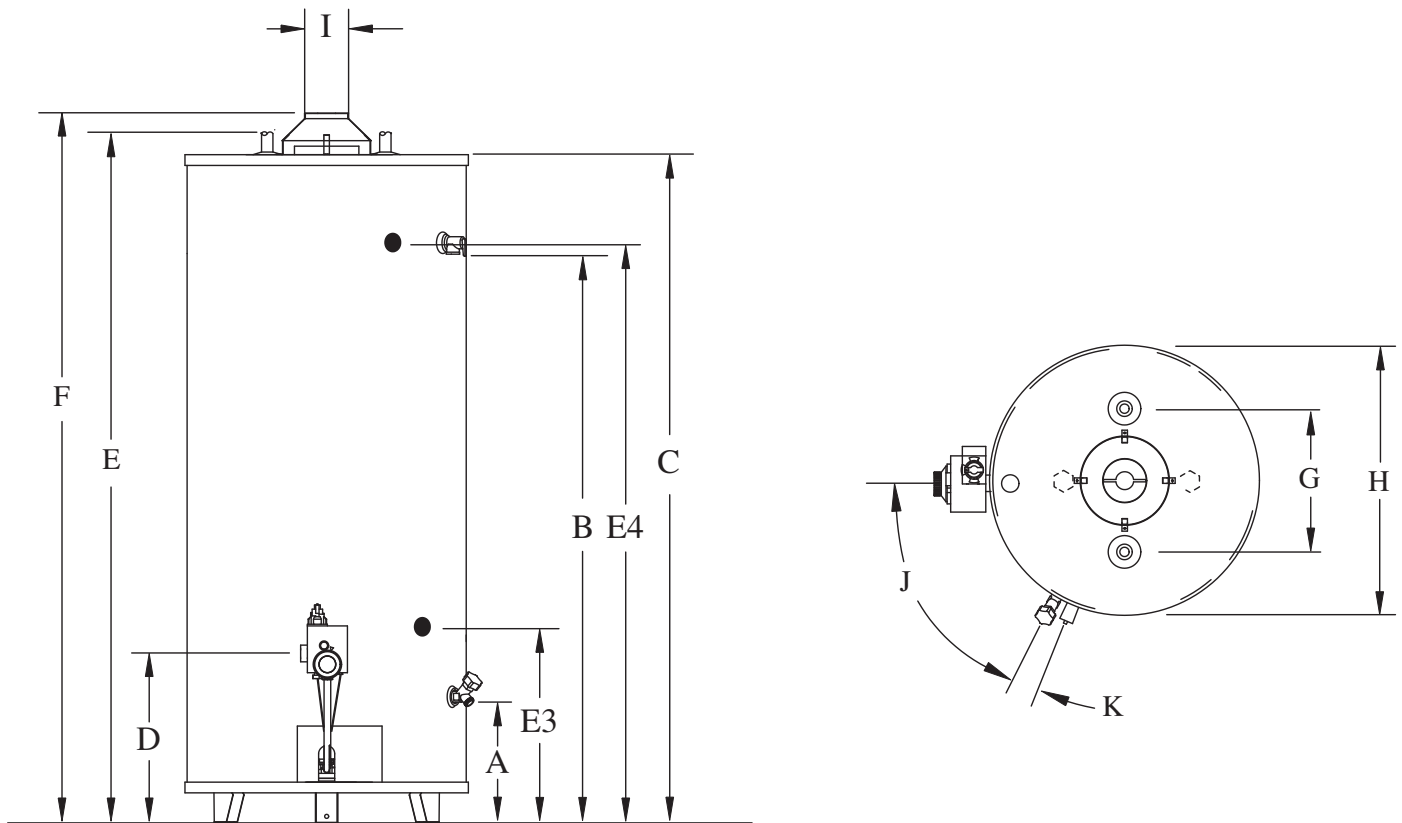

SPECIFICATIONS

Models	Storage Capacity			Input BTU	Recovery 90°F / 50°C			Estimated shipping weight	
	U.S. gal.	L	Imp. gal.		U.S. gal.	L	Imp. gal.	lb	kg
Natural Gas									
UG75-76ME-N2U	73	276	60.8	76,000	76.8	291	63.9	315	143

DIMENSIONS inches (cm)

Model	A	B	C	D	E	E3	E4	F	G	H	I	J	K
UG75	11 1/4 (29)	52 7/8 (134)	62 3/8 (158)	15 3/4 (40)	64 1/8 (163)	18 7/8 (48)	54 1/4 (138)	70 3/4 (180)	11 (28)	26 (66)	4 (10)	63.6°	7.8°

Input ratings are for 0 - 2,000 feet (0 - 610 metres) of altitude; de-rate 10% for high altitude models.

All models are suitable for combination potable water and space heating applications.

Toxic chemicals, such as those used for boiler treatment, must NEVER be introduced into this system. These units must NEVER be connected to any existing heating system or component(s) previously used with a non-potable water heating appliance.

WARRANTY

Giant light duty commercial gas water heaters have a six (6) year limited warranty against inner tank leakage from the date of installation. One (1) year limited warranty on component parts. For more specific warranty details including exceptions, consult the owner's manual that comes with each water heater.

Giant[®]
PROUDLY CANADIAN 

40 Lesage Avenue
Montréal-East, Québec, Canada, H1B 5H3
Telephone: (514) 645-8893
Toll free: 1 (800) 363-9354
General fax: (514) 640-0969
Customer Service fax: (514) 645-8413

giantinc.com

In accordance with our company policy of on-going product improvement, Giant Factories Inc. reserves the right to make changes without prior notice.