

# RESIDENTIAL GAS-FIRED POWER DIRECT VENT WATER HEATERS (EQUIPPED WITH FVIR TECHNOLOGY)

## OWNER'S MANUAL

### INSTALLATION AND OPERATING INSTRUCTIONS

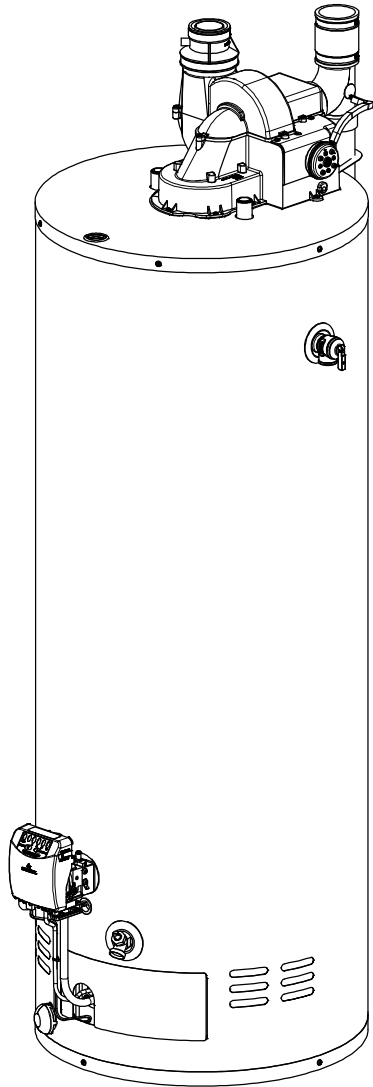

#### ⚠ WARNING

This water heater **IS NOT** design certified for installation in a mobile home or for installation outdoors.

#### ⚠ WARNING

If the information in these instructions is not followed exactly, a fire or explosion may result causing property damage, personal injury, or death.

**DO NOT** store or use gasoline or other flammable vapours and liquids in the vicinity of this or any other appliance.

#### WHAT TO DO IF YOU SMELL GAS

- **DO NOT** try to light any appliance.
- **DO NOT** touch any electrical switch.
- **DO NOT** use any phone in your building.
- **From a neighbour's phone, immediately call your gas supplier.** Follow the gas supplier's instructions.
- If you cannot reach your gas supplier, call the fire department.

Installation and service must be performed by a qualified installer, service agency, or the gas supplier.

#### IMPORTANT

READ THESE INSTRUCTIONS CAREFULLY BEFORE BEGINNING THE INSTALLATION. PROPER INSTALLATION WILL PROVIDE SAFE AND EFFICIENT SERVICE, AND AVOID NEEDLESS EXPENSES NOT COVERED BY THE WARRANTY. READ THE PRODUCT WARRANTY IN THE OWNER'S MANUAL AND REMEMBER TO FILL OUT AND RETURN TO THE MANUFACTURER ALL RELEVANT WARRANTY CARDS AND CERTIFICATES. SHOULD YOU HAVE ANY QUESTIONS, PLEASE CONTACT YOUR LOCAL DEALER OR REFER TO THE **SERVICE PROCEDURE** SECTION OF THE OWNER'S MANUAL. **SAVE THIS INSTRUCTION MANUAL FOR FUTURE REFERENCE.**

For your records, write the model and serial number here:

**Model #** \_\_\_\_\_

**Serial #** \_\_\_\_\_



C US  
LOW LEAD  
CONTENT



# TABLE OF CONTENTS

<b>Safety Information</b> .....	<b>3</b>	Installation Instructions for Water Heaters Approved for Combination Space Heating and Potable Water Heating .....	15
<b>Installation Instructions</b> .....	<b>4</b>	Installation Checklist .....	17
Altitude .....	4	<b>Operating Instructions</b> .....	<b>18</b>
Location .....	4	Operating the Water Heater .....	18
Minimum Clearances .....	4	Operating instructions .....	18
Venting .....	4	Water Temperature Regulation .....	19
Venting Connection to the water heater .....	5	Out of Fuel .....	20
Through-the-Wall Venting Installation .....	8	<b>General Maintenance</b> .....	<b>20</b>
Concentric Vent Termination Kit Installation (horizontal) .....	8	Housekeeping .....	20
Through-the-Roof Venting Installation .....	9	Flammable Vapour Sensor .....	20
Concentric Vent Termination Kit Installation (vertical) .....	10	Condensation .....	20
Pipe Assembly .....	10	Burner Ignitor Assembly .....	21
Vent Termination Through-The-Wall .....	11	Temperature and Pressure-Relief Valve .....	21
Vent Termination Through-The-Roof .....	12	Venting System Inspection .....	21
Restrictor Screens .....	12	Anode .....	21
Condensation in the Venting System .....	13	Draining the Water Heater .....	21
Water Piping .....	13	Vacation .....	21
Temperature and Pressure-Relief Valve .....	13	Service Procedure .....	22
Pressure Build-up in a Water System .....	14	<b>Replacement Parts</b> .....	<b>23</b>
Filling the Water Heater .....	14	<b>Troubleshooting Guide</b> .....	<b>24</b>
Gas Connections .....	14	<b>Model Dimensions</b> .....	<b>27</b>
Wiring .....	15	<b>Warranty</b> .....	<b>28</b>

## **WARNING**

### **Flammable Vapour Sensor**

Do not remove the protective cover. Do not spray water or leak detector products on this sensor. Do not expose this sensor to bleach or other liquid cleaning products. Avoid humid environments and freezing temperatures.

If the sensor detects the presence of flammable vapours, the gas control will switch to lock-out mode and the water heater will shut down. Do not try and restart the water heater. Have the water heater inspected immediately by a qualified service technician or the gas supplier.

If flammable vapours are detected:

- **DO NOT** try to light any appliance.
- **DO NOT** touch any electrical switch.
- **DO NOT** use any phone in your building.
- **From a neighbour's phone, immediately call your gas supplier.** Follow the gas supplier's instructions.
- If you cannot reach your gas supplier, call the fire department.

After the flammable vapours have been evacuated, contact a qualified service technician or the gas supplier to have the water heater inspected immediately. **Replacement of a FVIR technology equipped water heater due to a flammable vapour shutdown is not covered under the terms of the Standard Basic Limited Warranty.**

# SAFETY INFORMATION

Your safety and the safety of others is extremely important during the installation, operation and servicing of this water heater. Many safety-related messages have been provided in this manual and on your water heater. Always read and abide by all safety messages. These messages will point out the potential hazard, tell you how to reduce the risk of injury and tell you what will happen if the instructions are not followed.



This is the safety alert symbol. This symbol alerts you to potential hazards that can kill or hurt you and others. All safety messages will follow the safety alert symbol and either the word “**DANGER**” or “**WARNING**”.

## **DANGER**

Serious injury or death can occur if you do not follow the instructions **immediately**.

## **WARNING**

Serious injury or death can occur if you do not follow the instructions.

## **WARNING**

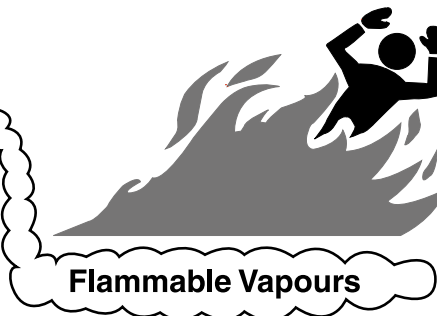

### **FIRE AND EXPLOSION HAZARD**

Can result in serious injury or death

 Do not store or use gasoline or other flammable vapours and liquids in the vicinity of this or any other appliance. Storage or use of gasoline or other flammable vapours or liquids in the vicinity of this or any other appliance can result in serious injury or death.

## **WARNING**

**DO NOT** use this water heater if any part has been under water. Immediately call a qualified service technician to inspect the water heater and to replace any part of the control system and any gas control which has been under water. Failure to follow this instruction can result in property damage, personal injury, or death.

# INSTALLATION INSTRUCTIONS

## IMPORTANT

These instructions have been written as a guide for the proper installation and operation of your water heater, and the manufacturer of this water heater will not accept any liability where these instructions have not been followed. However, for your safety and to avoid damage caused by improper installation, this water heater must be installed by a Certified Licensed Professional, and meet all local codes or, in the absence of local codes, the latest edition of CSA B149.1, Natural Gas and Propane Installation Code, in Canada, and/or the latest edition of the National Fuel Gas Code, ANSI Z223.1/NFPA 54, in the United States.

### Before proceeding with the installation instructions:

- 1) Inspect the water heater and its component parts for possible damage. **DO NOT** install or attempt to repair any damaged component parts. If you detect any damage, contact the dealer where the water heater was purchased or the manufacturer listed on the warranty card.
- 2) Verify that the type of gas being supplied corresponds to that which is marked on the rating plate and gas control of the water heater.

### Altitude

Input rating of this water heater is based on sea level operation. At higher elevations the actual input rate will be lower than the value listed on the rating plate due to the natural derating of natural gas and propane. This water heater can be installed at elevation up to 7,800 feet (2,377 m) without any change or modification. Do not attempt to adjust the input rate by changing the manifold pressure.

## ▲ WARNING

Failure to install a water heater suitable for the elevation at the location it is intended to serve, can result in improper operation of the appliance resulting in property damage and/or producing carbon monoxide gas, which could result in personal injury or death.

### Location

This water heater should be located close enough to the outside wall so that it is within the venting requirements listed in these installation instructions and as close as possible to the main use of hot water. This location must not be subject to freezing temperatures. The water heater should be positioned, so that there is easy access to the burner, gas control, and drain valve. It must be located close to a suitable free-flowing floor drain. Where a floor drain is not adjacent to the water heater, a suitable drain pan must be installed under the water heater (**see Figure 8**). In Canada, according to the National Plumbing Code, this drain pan shall be at least two (2) inches (5.1 cm) larger than the diameter of the water heater, and at least one (1) inch (2.5 cm) deep, providing access to the drain valve. Local codes may be more rigorous. This pan must be piped to a suitable drain to prevent damage to property in the event of a water leak from the piping, the relief valve, or the water heater.

**Sooner or later, all water heaters leak. The manufacturer, based on national building codes, has given the necessary instructions to prevent damage to the building. Under no circumstances is the manufacturer to be held liable for any water damage, in connection with this water heater.**

This water heater is approved for installation on either a combustible or non-combustible floor. However, should this water heater be installed directly on carpeting, the carpeting must be protected by a wood or metal panel beneath the water heater. This panel must extend at least three (3) inches (7.6 cm) beyond the width and depth of the water heater. Should the water heater be installed in an alcove or closet, the entire floor area must be covered by the panel.

### Minimum Clearances

The minimum clearances from combustible material for this water heater are: Two (2) inches (5.1 cm) from the sides and rear, four (4) inches (10.2 cm) from the front, and eighteen (18) inches (45.7 cm) from the top (**see Figure 1**).

**Figure 1**

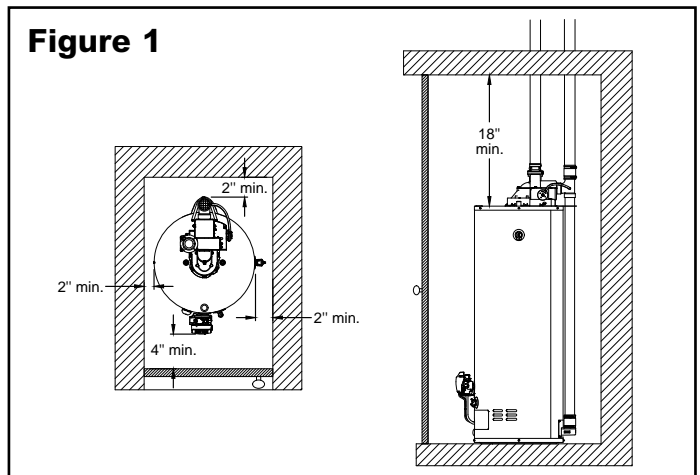

### Venting

## ▲ DANGER

When installing the venting system, make sure to follow all local codes or, in the absence of local codes, CSA B149.1, Natural Gas and Propane Gas Installation Code, in Canada and/or the National Fuel Gas Code, ANSI Z223.1/NFPA 54, in the United States. **NEVER** operate the water heater unless it is properly ventilated to the outdoors and has adequate air supply for proper operation. Failure to properly install the venting system could result in property damage, personal injury, or death.

# INSTALLATION INSTRUCTIONS

## IMPORTANT

According to the CSA B149.1, Natural Gas and Propane Installation Code, plastic vent systems installed in Canada must be certified to the STANDARD FOR TYPE BH GAS VENTING SYSTEMS, ULC S636. Components of the certified vent system must not be interchanged with other vent systems or unlisted pipe/fittings. Plastic components and specified primers and glues of the certified vent system must be from a single vent system manufacturer and not intermixed with other vent system manufacturer's vent system parts unless those are certified to be used with this system. Plastic vent systems shall also be installed such that the first three (3) feet (91 cm) of pipe from the water heater outlet are readily accessible for visual inspection. The air intake system does not have to meet the requirement of ULC S636, so regular schedule 40 PVC or CPVC pipes and fittings can be used to convey the flow of fresh air to the water heater.

This water heater is a power direct vent gas water heater that draws all of its combustion air from outside of the building and vents all of its combustion gases directly outside of the building.

This water can be vented using only one of the following options:

- Two (2) inch (5.1 cm) or three (3) inch (7.6 cm) schedule 40 PVC or CPVC pipe and fittings; **PVC CPVC**
- Two (2) inch (5.1 cm) or three (3) inch (7.6 cm) polypropylene rigid pipe and fittings from Centrotherm™ (InnoFlue® single wall vent system); **InnoFlue® Centrotherm™**
- Two (2) inch (5.1 cm) or three (3) inch (7.6 cm) polypropylene rigid pipe and fittings from DuraVent® (PolyPro® single wall vent system). **PolyPro® DuraVent®**

Use of cellular core PVC (ASTM F891), cellular core CPVC, or Radel® (polyphenolsulfone) in non-metallic venting systems is prohibited.

Before installing the vent piping, make sure that the vent system layout has been properly planned. Make sure that the flue baffle has been installed in the flue tube. If the baffle is not present, immediately contact the dealer where the water heater was purchased. **NEVER** operate the water heater without the flue baffle installed. Verify that the location of the water heater

**Table 1**

MAXIMUM EQUIVALENT LENGTH FOR VENT PIPE — DO NOT EXCEED		
VENT PIPE DIAMETER FOR 2" PDV MODELS ONLY	2 inches (5.1 cm)	3 inches (7.6 cm)
Maximum equivalent length*	50.0 feet (15.2 m)	180.0 feet (54.9 m)
Minimum equivalent length*	7.5 feet (2.3 m)	9.5 feet (2.9 m)
One 45° elbow is equivalent, in straight pipe, to	3.0 feet (0.9 m)	4.0 feet (1.2 m)
One 90° elbow is equivalent, in straight pipe, to	5.0 feet (1.5 m)	7.0 feet (2.1 m)
Concentric Vent Termination max. equivalent length (optional) horizontal	40.0 feet (12.2 m)	180.0 feet (54.9 m)
Concentric Vent Termination max. equivalent length (optional) vertical	40.0 feet (12.2 m)	180.0 feet (54.9 m)
Restrictor Screen	0 to 30 feet (9.1 m)	0 to 80 feet (24.4 m)
Restrictor Screen (for concentric vent termination)	0 to 25 feet (7.6 m)	0 to 80 feet (24.4 m)

\*Note: Outdoor termination elbow not to be counted when determining total length.

respects all clearances from combustible material, all venting requirements (**see Table 1**), and that the vent terminations will be installed as specified by all local codes or, in the absence of local codes, the latest edition of CSA B149.1, Natural Gas and Propane Installation Code, in Canada, and/or the latest edition of the National Fuel Gas Code, ANSI Z223.1/NFPA 54, in the United States (**see Figure 4**).

This water heater must be vented directly to the outdoors, either horizontally through the wall or vertically through the roof. The venting must not be attached to an existing chimney, or in common with any other appliance, and must not be insulated. If possible, locate the water heater so that the venting length and number of elbows are kept to the minimum necessary to reach the outside.

### Venting Connection to the water heater

#### PVC PIPE: **PVC**

A vent system adaptor should be installed when using PVC pipes for venting this water heater (**see Figure 2**). The vent system adaptor supplied with the water heater is made of IPEX parts. If another manufacturer of pipe is used to build the vent system, the vent system adaptor must be made from parts of that same manufacturer. To build the vent system adaptor, you will need a 2<sup>3/8</sup> inch (6 cm) long piece of two (2) inch CPVC pipe and a two (2) inch (5.1 cm) PVC coupling glued together with the proper cement.

#### CPVC PIPE: **CPVC**

The CPVC pipe must be inserted directly into the rubber transition fitting on the outlet of the blower assembly.

**Note:** If your installation requires three (3) inch (7.6 cm) pipe, you must start with two (2) inch (5.1 cm) pipe and add a two (2) to three (3) inch (5.1 cm to 7.6 cm) increaser to change the size of the pipe to three (3) inches (7.6 cm) (**see Figure 3**).

#### CENTROTHERM™ POLYPROPYLENE PIPE **InnoFlue® Centrotherm™** (InnoFlue® single wall vent system):

Use special appliance adapter from Centrotherm™ and insert into the rubber transition fitting on the outlet of the blower assembly. **Refer to the Table 2 and Figure 5** below for proper part number from Centrotherm™. On the three (3) inch (7.6 cm) vent pipe, an increaser is necessary.

**Table 2 — Centrotherm™**

	Appliance adapter	Increaser
2-inch (5.1 cm) pipe	ISAA0202	N/A
3-inch (7.6 cm) pipe	ISAA0202	ISIA0203

# INSTALLATION INSTRUCTIONS

## Figure 2

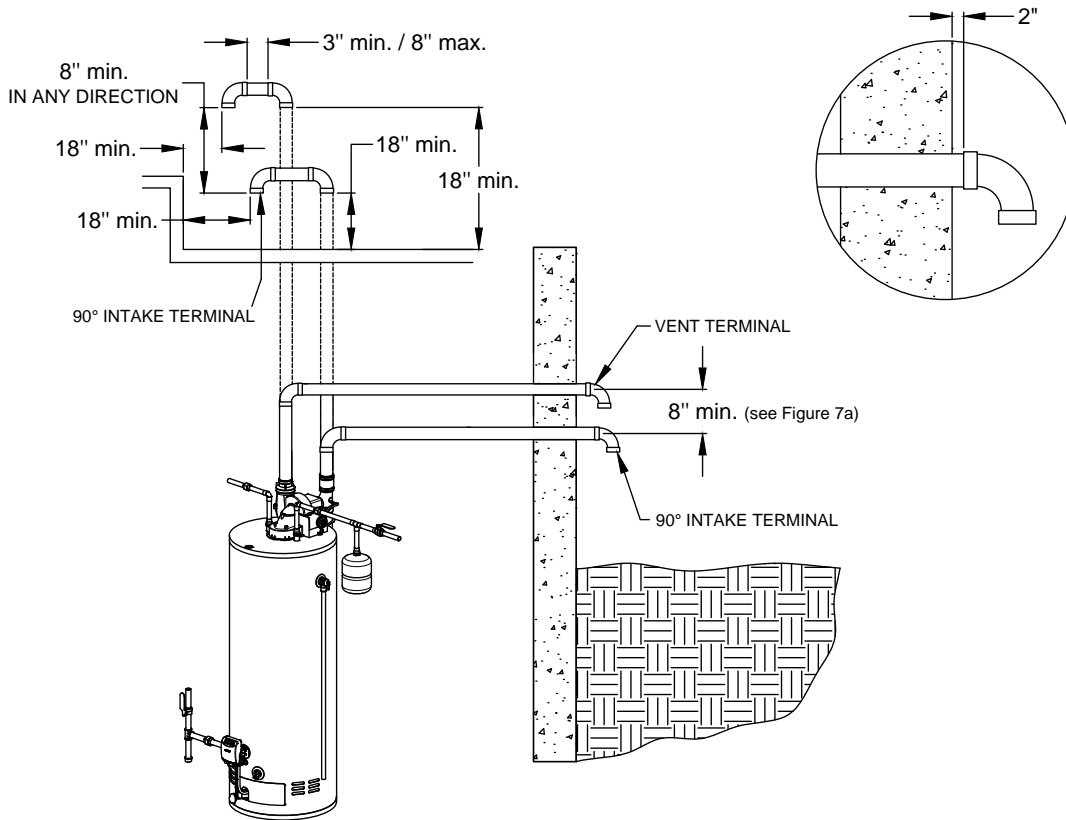

## Figure 3

Connection to a 2-inch (5.1 cm) vent system

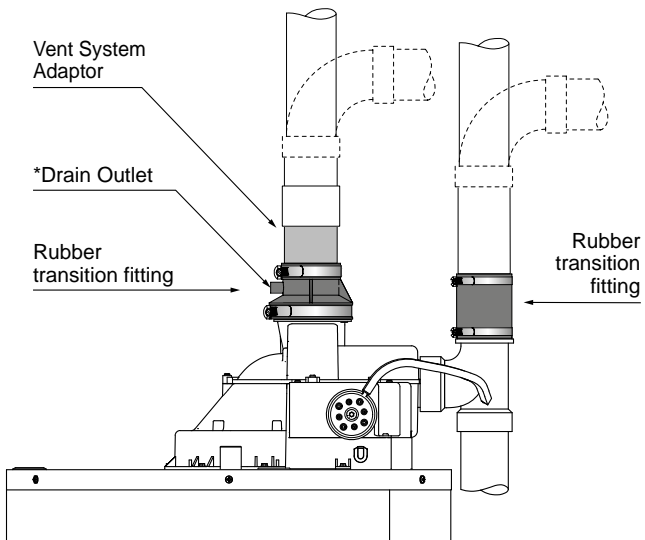

Connection to a 3-inch (7.6 cm) vent system

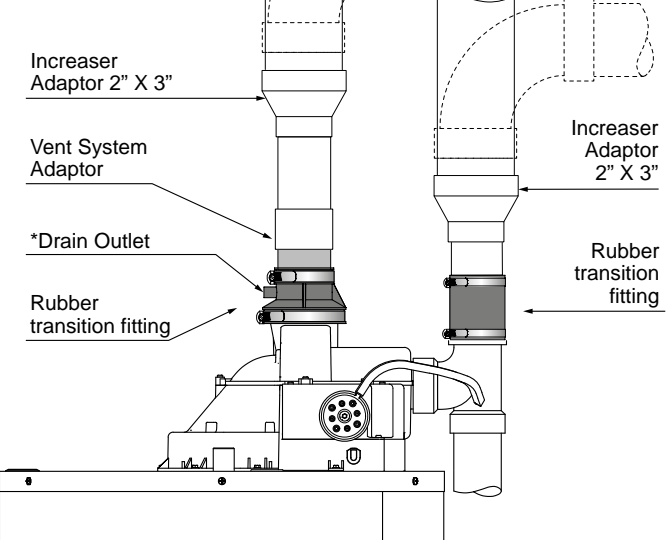

\*A plastic tube can be attached to the drain outlet to evacuate any condensate. For more information, consult the owner's manual, section Condensation in the venting system.

**The blower assembly must always have a two (2) inch (5.1 cm) rubber transition fitting. An increasing coupling 2" X 3" is necessary for a three (3) inch (7.6 cm) venting system. This coupling must be installed as close as possible after the rubber transition fitting and, in every case, before the first elbow.**

# INSTALLATION INSTRUCTIONS

**Figure 4**

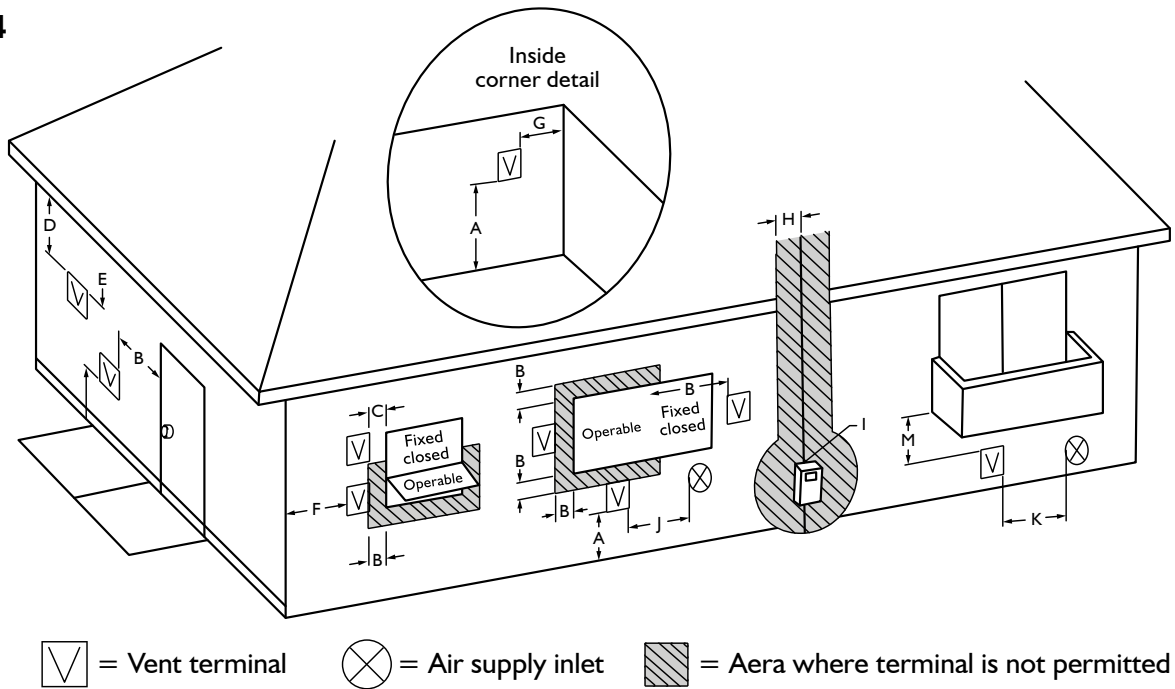

**The Vent Termination must have a:**

**Canadian Installations<sup>1</sup>**

**U.S. Installations<sup>2</sup>**

The Vent Termination must have a:	Canadian Installations <sup>1</sup>	U.S. Installations <sup>2</sup>
<b>A)</b> Clearance above grade, veranda, porch, deck, or balcony.	12 inches (30 cm)	12 inches (30 cm)
<b>B)</b> Clearance to windows or doors that may be opened.	12 inches (30 cm) for appliances > 10,000 Btuh (3 kW) and ≤ 100,000 Btuh (30 kW), 36 inches (91 cm) for appliances > 100,000 Btuh (30 kW).	12 inches (30 cm) for appliances > 10,000 Btuh (3 kW) and ≤ 100,000 Btuh (30 kW), 36 inches (91 cm) for appliances > 100,000 Btuh (30 kW).
<b>C)</b> Clearance to permanently closed windows.	*	*
<b>D)</b> Vertical clearance to ventilated soffit located above the terminal within a horizontal distance of 2 feet (61 cm) from the center line of the terminal.	*	*
<b>E)</b> Clearance to unventilated soffit.	*	*
<b>F)</b> Clearance to outside corner.	*	*
<b>G)</b> Clearance to inside corner.	*	*
<b>H)</b> Clearance to each side of center line extended above meter/regulator assembly.	*	*
<b>I)</b> Clearance to regulator vent outlet.	3 feet (91 cm) from the regulator vent outlet and 3 feet (91 cm) horizontally from the vertical center line of the regulator vent outlet to a maximum vertical distance of 15 feet (4.5 m).	*
<b>J)</b> Clearance to non-mechanical air supply inlet to building or the combustion air inlet to any other appliance.	12 inches (30 cm) for appliances > 10,000 Btuh (3 kW) and ≤ 100,000 Btuh (30 kW), 36 inches (91 cm) for appliances > 100,000 Btuh (30 kW).	12 inches (30 cm) for appliances > 10,000 Btuh (3 kW) and ≤ 100,000 Btuh (30 kW), 36 inches (91 cm) for appliances > 100,000 Btuh (30 kW).
<b>K)</b> Clearance to a mechanical air supply inlet.	6 feet (1.83 m)	3 feet (9 cm) above if within 10 feet (3 m) horizontally.
<b>L)</b> Clearance above paved sidewalk or paved driveway located on public property.	7 feet (2.13 m) <sup>†</sup>	*
<b>M)</b> Clearance under veranda, porch, deck, or balcony.	12 inches (30 cm) <sup>‡</sup>	*

**Notes:**

1) In accordance with the current CSA B149.1, Natural Gas and Propane Installation Code.

2) In accordance with the current ANSI Z223.1/NFPA 54, National Fuel Gas Code.

\* Clearance in accordance with local installation codes and the requirements of the gas supplier.

<sup>†</sup> A vent shall not terminate where it may cause hazardous frost or ice accumulation on adjacent property surfaces.

<sup>‡</sup> Permitted only if veranda, porch, deck, or balcony is fully open on a minimum of two (2) sides beneath the floor.

# INSTALLATION INSTRUCTIONS

## DURAVENT® POLYPROPYLENE PIPE

(PolyPro® single wall vent system): **PolyPro® DuraVent®**

Use special appliance adaptor from DuraVent® and insert into the vent system adaptor on the outlet of the blower assembly. **Refer to the Table 3 and Figure 6** below for proper part number from DuraVent®. On the three (3) inch (7.6 cm) vent pipe, an increaser is necessary. Make sure to use the appliance adapter clamp to connect the PolyPro® appliance adaptor to the vent system adaptor and to tighten both hose clamps on the appliance adapter clamp to ensure the connection is secure.

**Table 3 — DuraVent®**

	Appliance adaptor	Increaser	Appliance adaptor clamp
2-inch (5.1 cm) pipe	2PPS-AD	N/A	PPS-PAC
3-inch (7.6 cm) pipe	2PPS-AD	2PPS-X3	PPS-PAC

## Through-the-Wall Venting Installation

### ⚠ WARNING

When installing the vent piping make sure that the vent terminal is **NEVER** installed below the air intake terminal. The air intake terminal must always face downward. Failure to follow this instruction could result in property damage, personal injury, or death.

Two (2) vent terminal options are available to vent this water heater. The first is a standard 90-degree elbow facing downward (**see Figure 7a**) and the second is the concentric vent termination kit (**see Figure 7b**).

Cut or drill two (2) holes through the exterior wall, slightly larger than the diameter of the vent pipe selected. The larger holes will allow for final alignment with the water heater. Extend a section of pipe through each hole to the outside and attach the terminating elbow to the exterior end of each pipe. The vent and air intake terminals must be at least eight (8) inches (20.3 cm) apart and the vent terminal must **NEVER** be installed below the air intake terminal for any reason (**see Figure 7a**). The air intake terminal and the vent terminal must terminate on the same exterior wall (same atmospheric pressure zone).

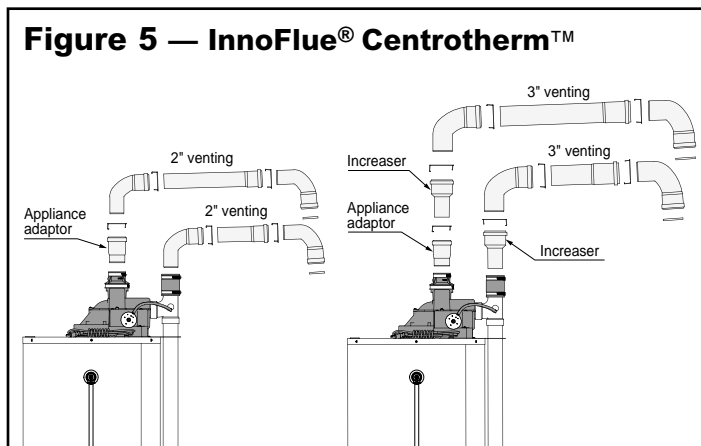

## ⚠ IMPORTANT

The air intake equivalent vent length must be equal to or less than the exhaust equivalent vent length and the air intake termination elbow shall be equipped with a standard wire mesh screen.

Connect and secure all piping and elbows from the power venter to the wall. When the installation is completed, the vent and air intake terminals must be at two (2) inches (5.1 cm) from the exterior surface of the wall (**see Figure 2**). Do not extend vent or air intake piping past this length. Make sure that all piping is properly supported. If the venting will pass through an enclosed area, make sure to leave at least one (1) inch (2.5 cm) clearance around the piping for air circulation.

## PVC AND CPVC PIPES: **PVC CPVC**

Make sure that all horizontal runs have a minimum rise of 1/4 inch per foot (21 mm/m) of run (**see Figure 8**). Horizontal runs of vent pipe must be supported every three (3) feet (91 cm).

## CENTROTHERM™ POLYPROPYLENE PIPE

(InnoFlue® single wall vent system): **InnoFlue® Centrotherm™**

Make sure that all horizontal runs have a minimum rise of 5/8 inch per foot (56 mm/m) of run. Follow instruction of the vent pipe manufacturer for proper vent support.

## DURAVENT® POLYPROPYLENE PIPE

(PolyPro® single wall vent system): **PolyPro® DuraVent®**

Make sure that all horizontal runs have a minimum rise of 1/4 inch per foot (21 mm/m) of run. Follow instruction of the vent pipe manufacturer for proper vent support.

## Concentric Vent Termination Kit Installation (horizontal)

A two (2) inch (5.1 cm) PVC or CPVC Concentric Vent Termination Kit (IPEX model #196005 or #197040) (with a two [2] inch [5.1 cm] restrictor screen from minimum equivalent length to twenty-five [25] feet [7.6 m]), or a three (3) inch (7.6 cm) PVC or CPVC Concentric Vent Termination Kit (IPEX model #196006 or #197009) (with a three (3) inch (7.6 cm) restrictor screen from minimum equivalent length to eighty [80] feet [24.4 m]) may be used for side wall termination installations. Using this

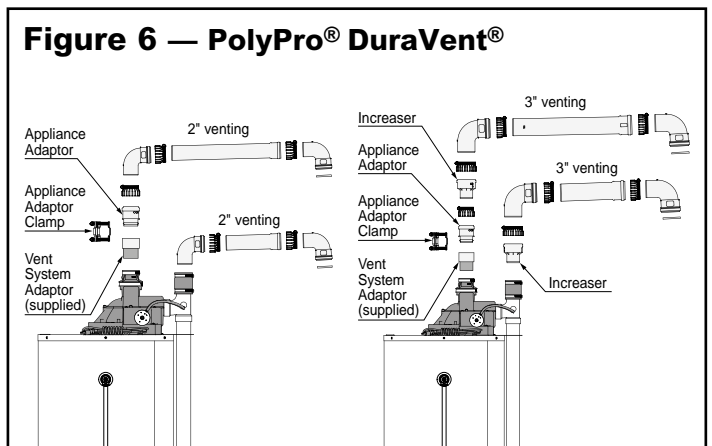



# INSTALLATION INSTRUCTIONS

**Figure 7a**

■ : Vent Terminal shall never be installed below air intake terminal and within 8" (20.3 cm) of air intake terminal.

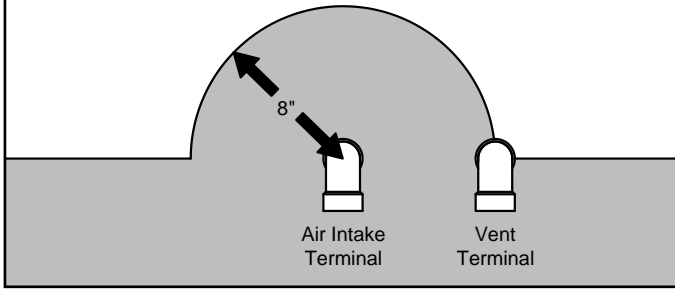

Concentric Vent Termination Kit will reduce the maximum allowable equivalent vent pipe length for both air intake and exhaust systems (see Table 1). Figure 7b illustrates the Concentric Vent Termination Kit for side wall installation. See manufacturer's instructions for complete installation details.

## Through-the-Roof Venting Installation

Cut or drill two (2) holes through the roof and ceiling, slightly larger than the diameter of the vent pipe selected. The larger holes will allow for final alignment with the water heater. Construct the vent terminal assembly. Extend a section of pipe through each hole in the roof to the outside and attach the terminal assembly to the exterior end of each pipe. The vent and air intake terminals must be at least eight (8) inches (20.3 cm) apart and the vent

**Figure 7b**

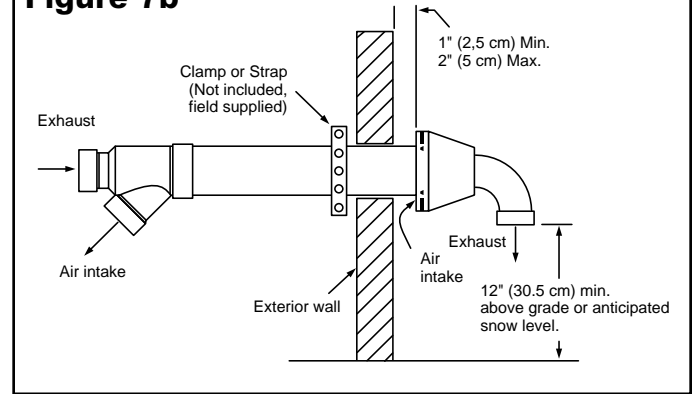

terminal must **NEVER** be installed below the air intake terminal for any reason (see Figure 2). The air intake terminal and the vent terminal must penetrate the same side of roof and be oriented facing downward in the same direction. Connect and secure all piping and elbows from the power venter to the roof. When the installation is completed, the air intake terminal must be at a minimum of eighteen (18) inches (45.7 cm) from the exterior surface of the roof or anticipated snow accumulation level (see Figure 2). The vertical terminations should be sealed with a plumbing roof boot or equivalent flashing. Make sure that all piping is properly supported. If the venting will pass through an enclosed area, make sure to leave at least one (1) inch (2.5 cm) clearance around the piping for air circulation.

**Figure 8**

Minimum slope (1/4" / foot (20.8 mm/m))

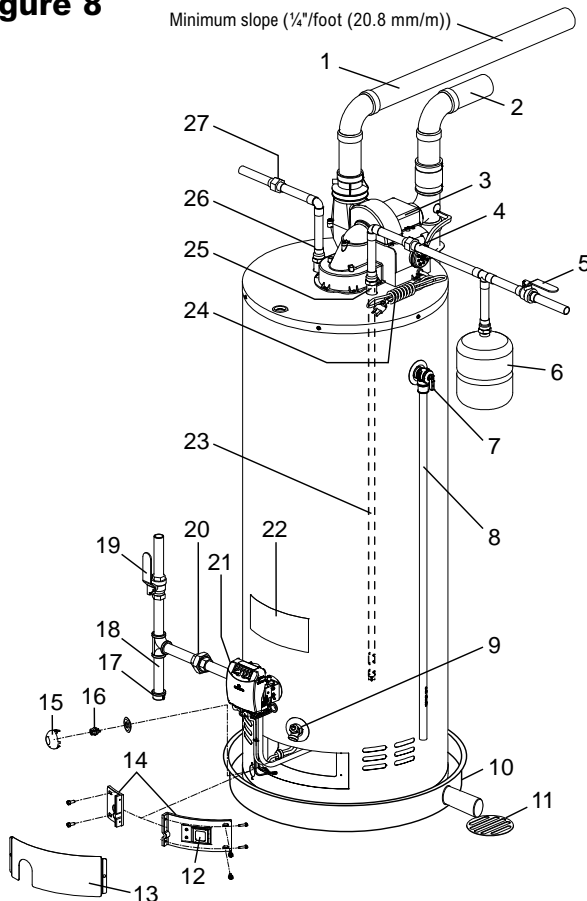

- |  |                                      |
|--|--------------------------------------|
| 1) Vent pipe                           | 17) Cap                              |
| 2) Air intake pipe                     | 18) Drip leg (Sediment trap)         |
| 3) Blower assembly                     | 19) Gas supply manual shut-off valve |
| 4) Union                               | 20) Union                            |
| 5) Cold water manual shut-off valve    | 21) Gas control                      |
| 6) Expansion tank                      | 22) Rating plate                     |
| 7) Temperature & pressure-relief valve | 23) Dip-tube                         |
| 8) Overflow tube                       | 24) Power cord                       |
| 9) Drain valve                         | 25) Cold water inlet                 |
| 10) Drain pan                          | 26) Hot water outlet                 |
| 11) Free-flowing floor drain           | 27) Union                            |
| 12) Sight glass                        | 28) Burner orifice                   |
| 13) Outer access door                  | 29) Ignitor                          |
| 14) Inner access doors                 | 30) Flame sensor                     |
| 15) Protective cover                   | 31) Burner                           |
| 16) Flammable vapour sensor            | 32) Manifold Spring (LP only)        |

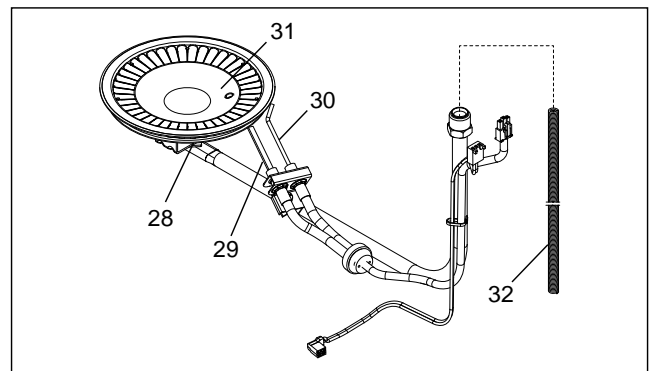

# INSTALLATION INSTRUCTIONS

## PVC AND CPVC PIPES: **PVC** **CPVC**

Make sure that all horizontal runs have a minimum rise of 1/4 inch per foot (21 mm/m) of run (see **Figure 2**). Horizontal runs of vent pipe must be supported every three (3) feet (91 cm) and vertical runs of vent pipe must be supported every five (5) feet (1.5 m).

## CENTROTHERM™ POLYPROPYLENE PIPE

(InnoFlue® single wall vent system): **InnoFlue** **Centrotherm**™

Make sure that all horizontal runs have a minimum rise of 5/8 inch per foot (56 mm/m) of run. Follow instruction of the vent pipe manufacturer for proper vent support.

## DURAVENT® POLYPROPYLENE PIPE

(PolyPro® single wall vent system): **PolyPro** **DuraVent**®

Make sure that all horizontal runs have a minimum rise of 1/4 inch per foot (21 mm/m) of run. Follow instruction of the vent pipe manufacturer for proper vent support.

## Concentric Vent Termination Kit Installation (vertical)

A two (2) inch (5.1 cm) Concentric Vent Termination Kit (IPEX model #196005 or #197040) (with a two [2] inch [5.1 cm] restrictor screen from minimum length to twenty-five (25) feet (7.6 m)), or a three (3) inch (7.6 cm) Concentric Vent Termination Kit (IPEX model #196006 or #197009) (with a three [3] inch [7.6 cm] restrictor screen from minimum length to eighty (80) feet (24.4 m)) may be used for through the roof termination installations. Using this Concentric Vent Termination Kit will reduce the maximum allowable equivalent vent pipe length for both air intake and exhaust systems (see **Table 1**). **Figure 9** and **Figure 10** illustrate the Concentric Vent Termination Kit for through the roof installation. See manufacturer's instructions for complete installation details.

**Figure 9**

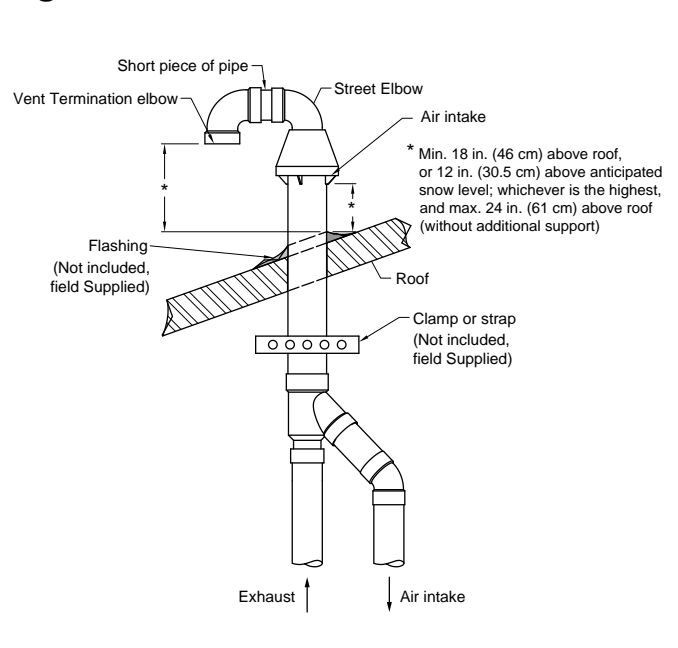

**Figure 10**

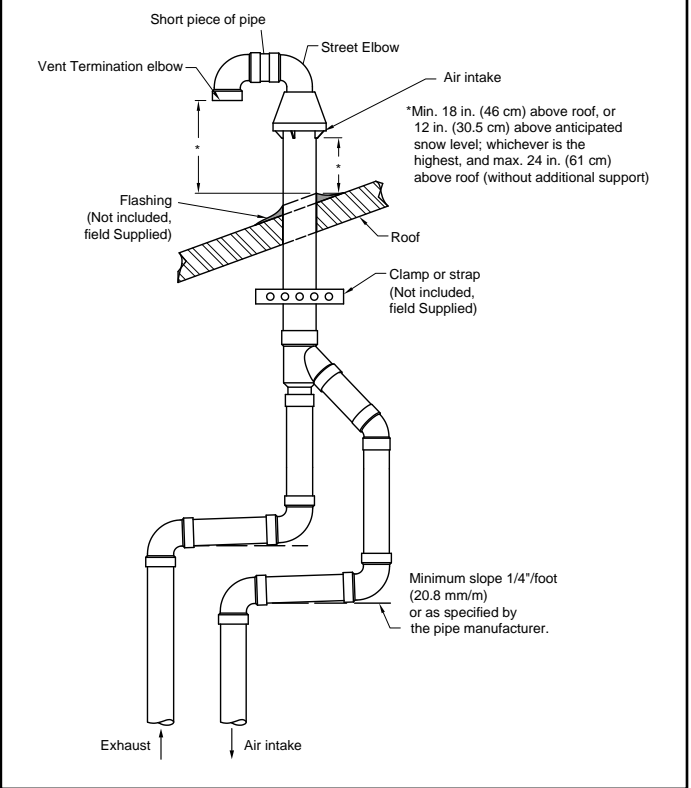

## Pipe Assembly

### ⚠ WARNING

**ALWAYS** read and abide by all safety messages printed on the primer, cleaner, and cement containers. Primer, cleaner, and cements are extremely flammable. **DO NOT** store these products near heat, sparks, or flames. They are harmful, or fatal if swallowed. Their vapours are also harmful. They may irritate eyes and can be absorbed through the skin. Failure to follow these instructions can result in property damage, personal injury, or death.

## PVC AND CPVC VENT SYSTEM: **PVC** **CPVC**

Primers, cleaners, solvents, and cements are available for PVC and CPVC pipe/fittings. When cementing the pipe/fittings, make sure to use only materials approved for the type of pipe/fittings to be installed and in all cases, follow the vent pipe/fittings manufacturers joining instructions. Never use all-purpose cements, commercial glues, and adhesives to join PVC or CPVC pipe/fittings.

- 1) Adjust the vent pipe length to properly fit the vent system adaptor on the blower assembly outlet.
- 2) Cut pipe ends squarely, removing all burrs and dirt.
- 3) Dry fit the pipe/fitting to be connected to make sure they fit properly.
- 4) Clean the pipe/fitting with the proper primer or cleaner.
- 5) Apply a thin coat of cement to the fitting, avoiding puddling inside.
- 6) Apply a liberal coat of cement to the vent pipe, leaving no voids.

# INSTALLATION INSTRUCTIONS

- 7) QUICKLY assemble parts while cement is fluid! If you wait too long, re-coat pipe/fitting.
- 8) Push the vent pipe completely into the coupling, turning as it goes until it bottoms out.
- 9) Hold pipe and fitting together for thirty (30) seconds. Then carefully clean off any excess material with a cloth. Allow connections a sufficient time to cure before disturbing.
- 10) Loosen the upper hose clamp on the rubber transition fitting and fully insert the CPVC pipe of the vent system adaptor one (1) inch (2.5 cm) deep. Do not apply cement to the rubber transition fitting.
- 11) Tighten the upper hose clamp to ensure the vent pipe is firmly secured and gas tight.
- 12) Make sure that the lower hose clamp is firmly seated, secured, and gas tight. Gently move the vent pipe side to side and vertically to ensure that it is securely in place and that there is no slippage.

**POLYPROPYLENE PIPE:** PolyPro® DuraVent® InnoFlue® Centrotherm™

Follow the vent pipe manufacturer installation instructions to assemble the vent pipe. Make sure to secure the vent pipe sections together using the mean (connector ring or locking band) as specified by the vent pipe manufacturer.

**Vent Termination Through-The-Wall**

**PVC AND CPVC VENT SYSTEM:** PVC CPVC

Two (2) 90-degree PVC elbows are supplied with the water heater and shall be installed at the end of the vent and air intake piping to serve as the termination for through-the-wall installation when the vent system is built with PVC pipes. If CPVC is used to build the vent system, use 90-degree CPVC elbows that are approved to be used with the vent system. A wire mesh screen must be installed in the termination elbows.

**POLYPROPYLENE VENT SYSTEM:**

PolyPro® DuraVent® InnoFlue® Centrotherm™

A 90-degree Polypropylene elbow, approved to be used with the vent system shall be used as the termination elbow for through-the-wall installation. Be sure to remove the wire mesh screen that was supplied with the 90-degree PVC elbow and insert it into the polypropylene elbow. Push the screen until it locks in place inside the elbow.

**VENT RISER**

When venting cannot exit through the wall at a height greater than or equal to twelve (12) inches (30.5 cm) above ground level, or anticipated snow level, the installation must be modified to include a vent riser as shown in **Figure 11**. The maximum equivalent length of vent pipe (including the vent riser) must be in accordance with the specifications in this manual.

In cold environment, where conditions present a risk of ice accumulation at the air intake terminal, the termination configuration shown in **Figure 12a** is recommended. Change the 90° termination elbows with 45° termination elbows. If it is impossible to maintain the twelve (12) inch

(30.5 cm) clearance above grade or anticipated snow level, the air intake terminal may be fitted with a riser similar to that on the vent terminal (**see Figure 12b**).

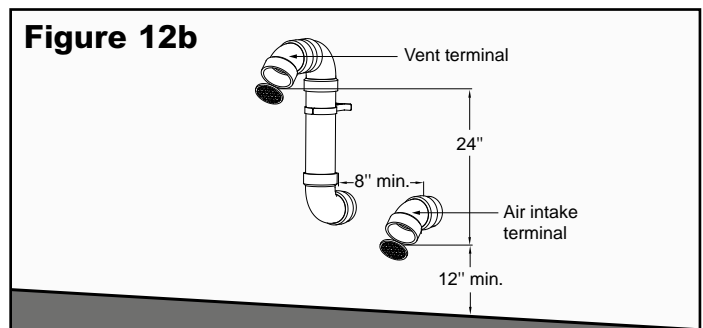
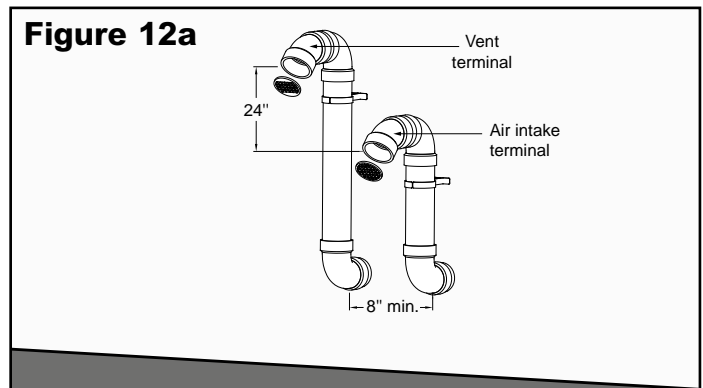
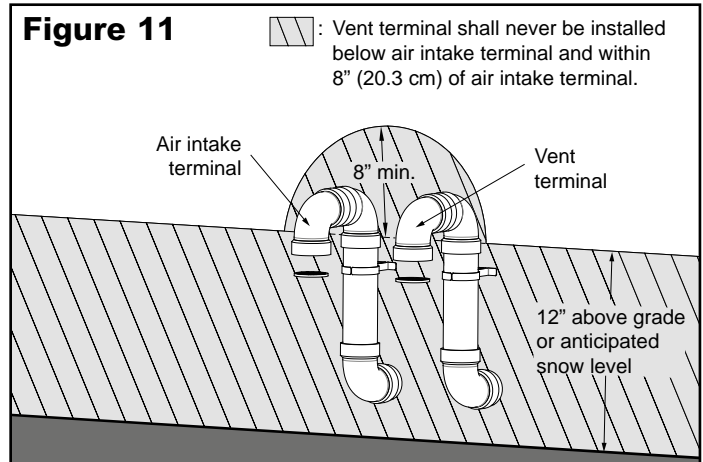

**Vent Termination Through-The-Roof**

**PVC AND CPVC VENT SYSTEM:** PVC CPVC

Two (2) 90-degree PVC elbows are supplied with the water heater and shall be installed at the end of the vent and air intake piping to serve as the termination for through-the-roof installation when the vent system is built with PVC pipes (**see Figure 3**). If CPVC is used to build the vent system, use 90-degree CPVC elbows that are approved to be used with the vent system. A wire mesh screen must be installed in the termination elbows.

**POLYPROPYLENE VENT SYSTEM:**

PolyPro® DuraVent® InnoFlue® Centrotherm™

A 90-degree Polypropylene elbow, approved to be used with the vent system shall be used as the termination elbow for through-the-roof installation. Be sure to remove the wire mesh

# INSTALLATION INSTRUCTIONS

**Table 4**

VENT SIZE	EQUIVALENT LENGTH	VENT TERMINAL	AIR INTAKE TERMINAL
2" (5.1 cm)	minimum vent to 30' (9.14 m)		
	30' (9.14 m) to 50' (15.2 m)		
3" (7.6 cm)	minimum vent to 80' (24.4 m)		
	80' (24.4 m) to 180' (54.9 m)		
CONCENTRIC VENT SIZE	EQUIVALENT LENGTH	VENT TERMINAL	AIR INTAKE TERMINAL
2" (5.1 cm)	minimum vent to 25' (7.6 m)		N/A
	25' (7.6 m) to 40' (12.2 m)		N/A
3" (7.6 cm)	minimum vent to 80' (24.4 m)		N/A
	80' (24.4 m) to 180' (54.9 m)		N/A

screen that was supplied with the 90-degree PVC elbow and insert it into the polypropylene elbow. Push the screen until it locks in place inside the elbow.

## ⚠ WARNING

Check that all openings and gaps in the outside wall or roof near and around where the vent and air intake pipes pass through are sealed to prevent infiltration of combustion products into the building.

## ⚠ WARNING

In freezing weather, check for snow accumulation around the water heater vent and air intake terminals where they pass through the outside wall or roof. The open ends of the terminals must be installed at least twelve (12) inches (30.5 cm) above the highest anticipated snowfall to prevent blockage by snow.

### Restrictor Screens

PVC AND CPVC VENT SYSTEM:

Two (2) black restrictor screens (two [2] inches [5.1 cm] and three [3] inches [7.6 cm]) are provided in the box (see **Figure 13**). When using a two (2) inch (5.1 cm) vent, the two (2) inch (5.1 cm) black restrictor screen must be installed in the vent termination elbow when total equivalent length is thirty (30) feet (9.1 m) or less, otherwise a standard wire mesh screen shall be installed. When using a three (3) inch (7.6 cm) vent, the three (3) inch (7.6 cm) black restrictor screen must be installed in the vent termination elbow when total equivalent length is eighty (80) feet (54.9 m) or less, otherwise a standard wire mesh screen shall be installed.

When using a two (2) inch (5.1 cm) concentric vent system from IPEX, be sure to install the two (2) inch (5.1 cm) black restrictor screen when total equivalent length is twenty-five (25) feet (7.6 m) or less, otherwise a standard wire mesh screen shall be installed. If using the three (3) inch (7.6 cm) concentric vent system from IPEX, be sure to install the three (3) inch (7.6 cm) black restrictor screen when total equivalent length is eighty (80) feet (54.9 m) or less, otherwise a standard wire mesh screen shall be installed.

### POLYPROPYLENE VENT SYSTEM:

Two (2) grey restrictor screens (two [2] inches [5.1 cm] and three [3] inches [7.6 cm]) are provided in the box (see **Figure 13**). When using a two (2) inch (5.1 cm) vent, the two (2) inch (5.1 cm) grey restrictor screen must be installed in the vent termination elbow when total equivalent length is thirty (30) feet (9.1 m) or less, otherwise a standard wire mesh screen shall be installed. When using a three (3) inch (7.6 cm) vent, the three (3) inch (7.6 cm) grey restrictor screen must be installed in the vent termination elbow when total equivalent length is eighty (80) feet (54.9 m) or less, otherwise a standard wire mesh screen shall be installed. To install the restrictor screen, remove the gasket at the end of the termination elbow and insert the restrictor screen. Push firmly the screen into the elbow pass the gasket groove. Put the gasket back into place.

**Figure 13**

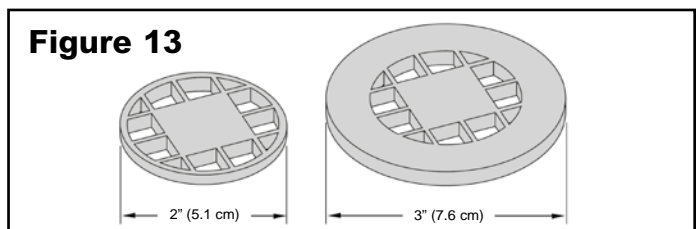

# INSTALLATION INSTRUCTIONS

The screen can be removed on the air intake terminal in cold environment. Thus, this may make the air intake susceptible to debris build-up in the air intake pipe. A second screen is installed in the air inlet "T" fitting at the back of the water heater to prevent debris from entering the water heater. This screen can be accessed for cleaning by removing the pipe on top of the rubber adaptor. If the air intake screen is removed to prevent freezing, it is recommended that the air intake screen be reinstalled in the spring.

## ⚠ DANGER

When the installation is complete, visually inspect the venting system to make sure that all joints are properly connected and all instructions have been followed. Failure to properly install the venting system could result in property damage, personal injury, or death.

### Condensation in the Venting System

In some installations, condensation will form in the horizontal runs of vent piping. In order to effectively control the condensation from adversely affecting the mechanical components of the water heater (draining back into the blower), a rubber transition fitting with a drain outlet is mounted directly on the blower vent outlet.

**Note:** When the installation requires it, proceed with the following steps otherwise, make sure that the removable cap of the condensate outlet is in place.

- Remove the cap on the drain outlet.
- Connect a clear, flexible, PVC tube with an inside diameter of 1/2 inch, or an equivalent material to the drain outlet. The drain tube must be of sufficient length to reach a suitable free-flowing drain or other required condensate disposal termination requirements (Refer to local codes).
- Loop the drain tube so that it has a circular trap (approximately eight (8) inches (20.3 cm) in diameter) and secure the top and bottom with zip ties as shown in **Figure 14**.
- Fill the drain tube with water (at least halfway) so that no combustion gases might vent into the room.
- Route the drain tube to the floor drain and secure the tube in a vertical position to the side of the water heater.

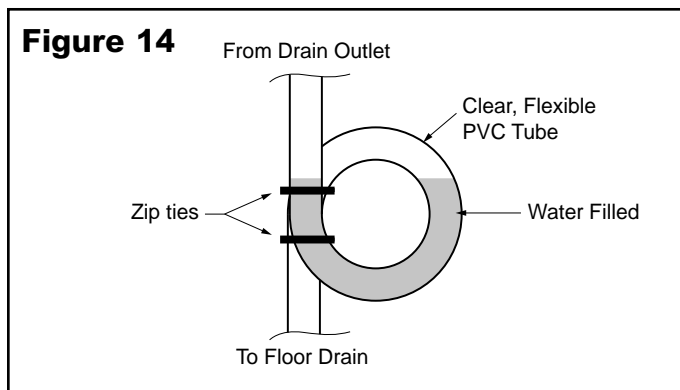

### Water Piping

Refer to **Figure 8** for a typical installation. Use of this layout should provide a trouble-free installation for the life of the water heater. Before making the plumbing connections, locate the **COLD** water inlet and the **HOT** water outlet. These fittings are both 3/4" NPT male thread. Make sure that the dip-tube is installed in the cold water inlet. Install a shut-off valve close to the water heater in the cold water line. It is recommended that unions be installed in the cold and hot water lines so that the water heater can be easily disconnected, if servicing is required.

When assembling the hot and cold piping to the water heater, use Teflon™ tape or a good food grade of pipe joint compound, and ensure all fittings are tight. **DO NOT APPLY HEAT TO THESE FITTINGS** when making sweat connections to the water heater. Sweat (solder) tubing to threaded adaptors before connecting to the water heater. **IT IS IMPERATIVE THAT NO HEAT BE APPLIED** to the cold water inlet, as it contains a non-metallic dip-tube. **This will result in premature failure of the fittings, which is not covered by the warranty.**

### Temperature and Pressure-Relief Valve

## ⚠ WARNING

**DO NOT** plug the temperature and pressure-relief valve or its discharge line. **DO NOT** remove the relief valve. Make sure the relief valve is properly sized for the water heater. If the relief valve continuously discharges water, call a qualified service technician to correct the problem. Failure to follow these instructions can result in property damage, personal injury, or death.

To protect from excessive pressure and/or temperature, the manufacturer has installed a temperature and pressure-relief valve that meets the requirements of the Standard for Relief Valves and Automatic Gas Shut-Off Devices for Hot Water Supply Systems, CSA 4.4, in Canada, and ANSI Z21.22, in the United States. This relief valve has a maximum set pressure that does not exceed the hydrostatic working pressure of the water heater (150 psi = 1,035 kPa) and a Btuh rating equal to or greater than the input rating, as shown on the water heater rating plate. It should never be plugged or removed from the opening marked for it on the water heater.

If this relief valve should need to be replaced, use only a new temperature and pressure-relief valve. **NEVER** install an old or existing relief valve, as it may be damaged or inadequate for the working requirements of the new water heater. This new relief valve must meet all local codes or, at a minimum, the requirements listed above. **NEVER** install any other type of valve between the relief valve and the water heater.

# INSTALLATION INSTRUCTIONS

A discharge line must be installed into the relief valve. The discharge line:

- Must not be smaller than the outlet diameter of the relief valve.
- Must not terminate less than six (6) inches (15.2 cm) and not more than twelve (12) inches (30.5 cm) above floor.
- Must not be restricted in any way. Do not thread, cap, or in any way restrict the end of this outlet.
- Must be of a material capable of withstanding 210°F (99°C) without distortion.
- Must be installed to allow complete drainage of the relief valve and discharge line.
- Must terminate above an adequate free-flowing drain.

## Pressure Build-up in a Water System

When the water heater operates, the heated water expands creating a pressure build-up. This is a natural function and is one of the reasons for installing a temperature and pressure-relief valve. If the cold water supply line has a built-in water meter, check valve, or pressure-reducing valve, a suitable expansion tank must be installed to prevent pressure build-up or water hammer effect. Otherwise, the warranty is void (**see Figure 8**). An indication of pressure build-up is frequent discharges of water from the relief valve. If the relief valve discharges water on a continuous basis, it may indicate a malfunction of the relief valve, and a qualified service technician must be called to have the system checked, and the problem corrected.

## Filling the Water Heater

### ⚠ WARNING

**NEVER** operate the water heater unless it is completely filled with water. **Failure to follow this instruction can result in premature failure of the water heater that is not covered by the warranty.**

Check that all of the water piping connections have been made. To fill the water heater:

- 1) Make sure that the water heater drain valve is closed by inserting a flat head screwdriver into the slot on the head of the drain valve and turning the knob clockwise .
- 2) Open the cold water supply manual shut-off valve. This valve must remain open, as long as the water heater is in use. **NEVER** operate the water heater with the cold water supply manual shut-off valve closed.
- 3) To make sure the water heater is completely full of water, open all of the hot water faucets in the house to let the air out of the water heater and plumbing system. Leave the faucets open until a constant flow of water is obtained.
- 4) Check all of the plumbing connections to make sure there are no leaks.

## Gas Connections

### ⚠ WARNING

**DO NOT** attempt to use this water heater with any gas other than the type of gas shown on the water heater rating plate. Failure to follow this instruction can result in property damage, personal injury, or death.

The gas piping must be installed as indicated in **Figure 8**. For the correct size of piping for this water heater, consult the latest edition of CSA B149.1, National Gas and Propane Installation Codes, in Canada, and/or the latest edition of the National Fuel Gas Code, ANSI Z223.1/NFPA 54, in the United States. Only new piping with cleanly cut threads may be used, together with a suitable sealing compound that is approved for natural gas and propane. It is mandatory that a readily accessible manual shut-off valve be installed in the gas supply line. The gas supply manual shut-off valve must be close to the water heater. A drip leg (sediment trap) must be installed in the gas line ahead of the gas control to prevent dirt from entering it. A union must be installed between the gas control valve and the gas supply manual shut-off valve for easy maintenance of the water heater.

### ⚠ WARNING

**NEVER** use an open flame to test for gas leaks. A fire or explosion could occur resulting in property damage, personal injury, or death.

The water heater and its gas connection must be leak tested before placing the appliance into operation. To leak test the system:

- 1) Turn on the manual gas shut-off valve near the water heater.
- 2) Use a soapy water solution to test all connections and fittings for leaks. Bubbles indicate a gas leak.
- 3) Correct all leaks.

Make sure that the inlet pressure to the water heater does not exceed 1/2 PSI (3.5 kPa) for both natural gas and propane. Pressures in excess of 1/2 PSI (3.5 kPa) can damage the gas control, resulting in a fire or explosion from leaking gas. For purposes of adjustment, the minimum inlet pressure is indicated on the water heater rating plate.

If any pressure testing of the gas line is undertaken at test pressures in excess of 1/2 PSI (3.5 kPa), the water heater and its gas supply manual shut-off valve must be disconnected from the gas supply piping system, and the end of the pipe sealed with a female cap. If the testing is to be undertaken at a test pressure less than 1/2 PSI (3.5 kPa), the gas supply manual shut-off valve must be closed.

# INSTALLATION INSTRUCTIONS

## ⚠ WARNING

U.L. and CSA recognized fuel gas and Carbon Monoxide (CO) detectors are recommended in all applications and should be installed using the manufacturer's instructions and local codes, rules, or regulations.

### Wiring

## ⚠ WARNING

This water heater uses an external electrical source for power. It must be electrically grounded in accordance with all local codes or, in the absence of local codes, the latest edition of CAN/CSA C22.1 Canadian Electrical Code, in Canada, and/or the latest edition of the National Electrical Code, ANSI/NFPA 70, in the United States. Failure to properly ground this water heater can result in property damage, personal injury, or death.

Before lighting your water heater, check that all of the wires have been installed correctly (**see Figure 15**). Make sure that none of the wires are grounded, have split, or are broken. Verify that all wiring connections are properly secured, as there is a possibility that they have become loose during transport. If any of the original wiring needs replacing, use only 18AWG-type or greater wire that is approved for 221°F (105°C).

### Installation Instructions for Water Heaters Approved for Combination Space Heating and Potable Water Heating (see Figure 16)

A water heater cannot be used for space heating only. When using a water heater for combination space and potable water heating, the instructions provided in this manual and with the air-handling unit must be respected and, **in particular**, the following:

- 1) All piping and components that are used in the system must be of a nonferrous type suitable for potable water. This also applies to any sealant used.
- 2) When used as a dual purpose water heater, it must not be connected to any system that has been previously used for non-potable water heating. This includes any piping because, in all probability, existing piping would have been, in the past, treated with chemicals for cleaning or sealing the system.
- 3) If this water heater is to be used for space heating, make sure that all safety codes are respected. Pay special attention to safety valve pressure and expansion tanks.
- 4) Do not use toxic chemicals to clean the potable water heating system.

- 5) Where water temperature in excess of 140°F (60°C) is required for a space heating application, a mixing valve must be installed in the potable side of the system. This will temper the water and reduce the risk of scalding.
- 6) If the incoming water line to the heater is equipped with a check valve, water meter, or pressure-reducing valve, an expansion tank must be installed in the system. This will prevent weeping from the water heater relief valve and premature failure of the heater due to expansion of the water during the heating cycle.
- 7) Before acquisition of a water heater for space heating application, it is necessary to have the area of intended use sized by a qualified technician. This will ensure that an adequate water heating capacity will be available for both heating and potable water supply, and that the application will meet all local codes and public utility requirements.

**Note:** It is good practice to oversize the water heater, to ensure that all of the potential hot water requirements are available.

# INSTALLATION INSTRUCTIONS

## Wiring Diagram

Figure 15

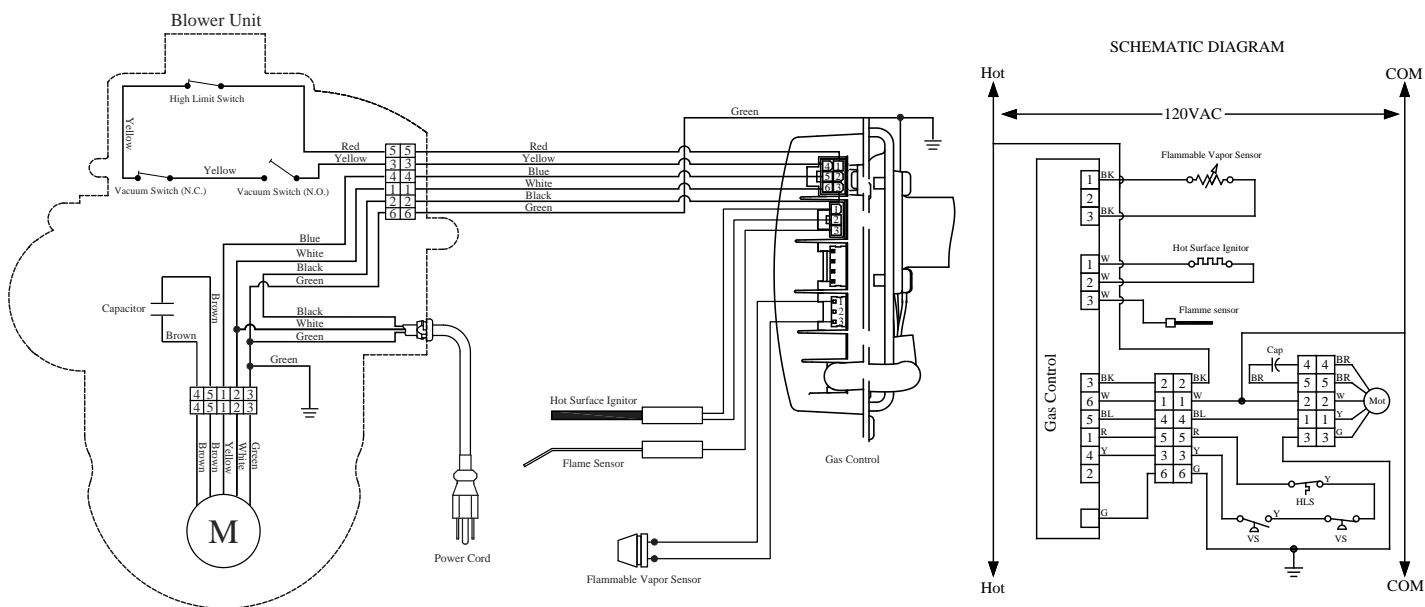

55000212 55000214

Figure 16

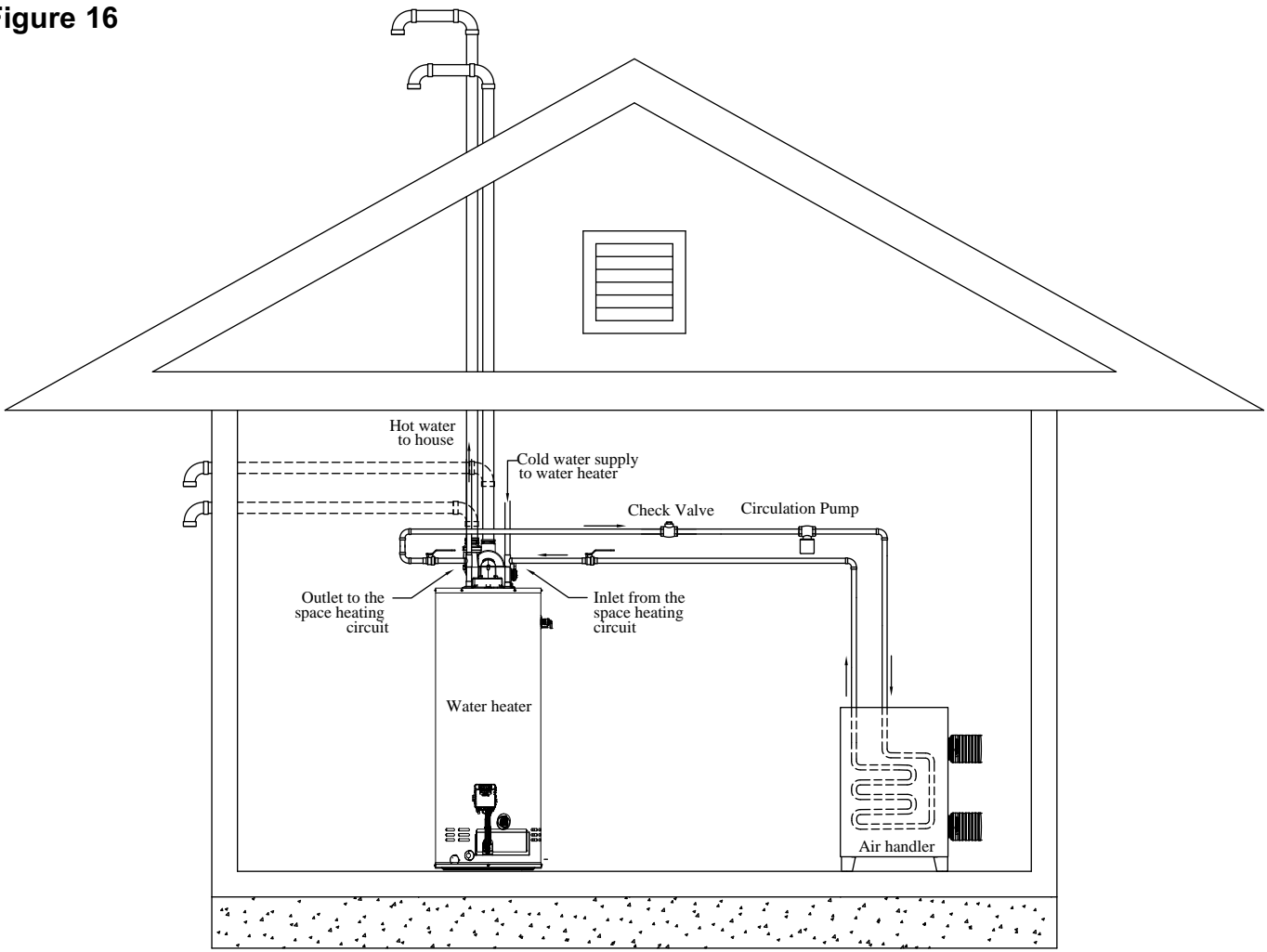



# INSTALLATION INSTRUCTIONS

## Installation Checklist

### Location

- Is the water heater located within the venting requirements and close to the main use of hot water? .....
- Is the water heater protected from freezing temperatures? .....
- Has a drain pan been installed and piped to a free-flowing drain? .....
- Is the gas control accessible for servicing? .....
- Have clearances from combustible materials been observed? .....

### Combustion and Ventilation Air Supply

- Is the area around the water heater clean and properly ventilated? .....
- Is the fresh air supply free of corrosive elements and flammable vapours? .....
- Does the water heater have access to enough fresh combustion air? .....

### Venting

- Is the flue baffle installed in the flue tube? .....
- Has the water heater been vented separately from all other appliances? .....
- Has the vent piping been assembled with pipes and fittings from the same manufacturer? .....
- Have all horizontal runs of vent pipe been installed with a minimum rise as specified? .....
- Has all the vent piping been secured with the appropriate primer and solvent-based cement when necessary? .....
- Has the venting been supported at the proper intervals? .....
- Have precautions been taken against condensation flowing into the power venter? .....

### Water Piping

- Is the dip-tube installed in the cold water inlet? .....
- Has a temperature and pressure-relief valve been installed? .....
- Does this valve have a discharge line installed, and is it piped to a free-flowing drain? .....
- Have all the plumbing connections been properly installed, and are they leak-free? .....
- Is the water heater full of water? .....

### Gas Connections

- Is the gas supplied to the water heater the same type as indicated on the water heater rating plate? .....
- Has the gas line been installed with a manual shut-off valve, union, and drip leg? .....
- Is the gas piping large enough and made of an approved material? .....
- Have all connections been made with an approved joint compound? .....
- Has the gas piping been tested for leaks with a soap and water solution? .....

### Wiring

- Has the wiring been properly installed? .....
- Have the electrical connections been checked, and are they secure? .....
- Is the water heater electrically grounded? .....
- Does the 120V wall receptacle have the proper polarity? .....

# OPERATING INSTRUCTIONS

## Operating the Water Heater



Before lighting or re-lighting your water heater, make sure that you have read and understood all of the instructions and warnings in this manual and on your water heater. If you have any questions about lighting your water heater, immediately

contact a qualified installer, service agency, or the gas supplier.

## ⚠ WARNING

**DO NOT** operate this water heater if:

- It is not full of water.
- The gas supplied does not match the type listed on the rating plate.
- Gasoline or other flammable vapours and liquids have been stored in the vicinity of the water heater.

Failure to follow these instructions can result in property damage, personal injury, or death.

## Operating Instructions

### FOR YOUR SAFETY READ BEFORE OPERATING

**WARNING: If you do not follow these instructions exactly, a fire or explosion may result causing property damage, personal injury, or loss of life.**

**A.** This appliance does not have a pilot. It is equipped with an ignition device which automatically lights the burner.

**DO NOT** try to light the burner by hand.

**B. BEFORE OPERATING** - Smell all around the appliance area for gas. Be sure to smell next to the floor because some gas is heavier than air and will settle on the floor.

#### WHAT TO DO IF YOU SMELL GAS:

- **DO NOT** try to light any appliance.
- **DO NOT** touch any electric switch; **DO NOT** use any phone in your building.
- Immediately call your gas supplier from a neighbor's phone. Follow the gas supplier's instructions.

- If you cannot reach your gas supplier, call the fire department.

**C.** Use only your hand to slide the gas control switch or press the temperature adjustment buttons. Never use tools. If the switch or buttons cannot be activated by hand, don't try to repair it, call a qualified service technician. Force or attempted repair may result in a fire or explosion.

**D.** Do not use this appliance if any part has been under water. Immediately call a qualified service technician to inspect the appliance and to replace any part of the control system and any gas control which has been under water.

## OPERATING INSTRUCTIONS

1. **STOP!** Read the safety information above (to the left) on this label.
2. Toggle the "ON/OFF" switch located on the gas control to the "ON" position.
3. Set the thermostat to the lowest setting by pressing the COOLER (◀) and HOTTER (▶) buttons at the same time and holding them for one (1) second. Then press the COOLER (◀) button until only the VAC indicator light is lit.
4. Toggle the "ON/OFF" switch located on the gas control to the "OFF" position.

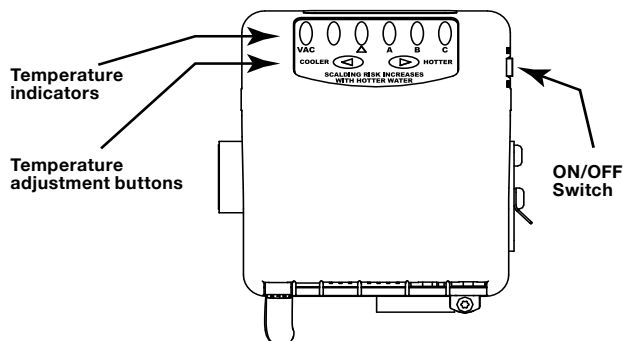

5. Turn off all electrical power to the appliance.
6. This appliance is equipped with an ignition device which automatically lights the burner. **DO NOT** try to light the burner by hand.
7. Wait five (5) minutes to clear out any gas. Then smell for gas, including near the floor. If you smell gas, **STOP!** Follow step "B" in the safety information above (to the left) on this label. If you do not smell gas, go to the next step.
8. Turn on all electrical power to the appliance.
9. Toggle the "ON/OFF" switch located on the gas control to the "ON" position.
10. Set thermostat to the desired temperature setting by pressing the COOLER (◀) and HOTTER (▶) buttons at the same time and holding them for one (1) second. Then press the HOTTER (▶) button until the desired temperature display setting is lit. The preferred starting point for temperature setting is indicated by ▲ on the temperature indicators.
11. If the appliance will not operate, follow the instructions "TO TURN OFF GAS TO APPLIANCE" and call your service technician or gas supplier.

### TO TURN OFF GAS TO APPLIANCE

1. Set the thermostat to the lowest setting by first pressing the COOLER (◀) and HOTTER (▶) buttons at the same time and holding for one (1) second. Then press the COOLER (◀) button until only the VAC indicator light is lit.
2. Toggle the "ON/OFF" switch located on the gas control to the "OFF" position.
3. Turn off all electrical power to the appliance if service is to be performed.

# OPERATING INSTRUCTIONS

## Water Temperature Regulation

### ⚠ WARNING

The higher the temperature setting, the greater the risk of scalding. Hot water can cause third degree burns in under one (1) second at 160F (71°C), in five (5) seconds at 140°F (60°C), and in thirty (30) seconds at 130°F (54°C). In households where there are children, physically challenged individuals, or elderly persons, mixing valves for point of use are necessary as means of reducing the scalding potential of hot water.

When the water heater is plugged in for the first time, the gas control will start to heat the water to the factory adjusted temperature. To avoid any unintentional changes in the water temperature settings, the gas control has a tamper-resistant feature included for changing the temperature setting. If you want to change this setting for either cooler or warmer water, the following steps are necessary:

1. “Wake up” the temperature indicators by holding down both the **COOLER** and **HOTTER** temperature adjustment buttons at the same time for one (1) second (see **Operating Instructions**). One or two of the temperature indicators will light up. These indicators will only remain on for thirty (30) seconds, if no further buttons are pressed. After thirty (30) seconds, the control will go back to “Sleep” mode, and both buttons will again have to be pressed to see the water temperature setting. Release both of the temperature adjustment buttons. **See Figure 17** for an explanation of what each of the temperature indicators mean.



**To decrease the temperature**, press and release the **COOLER** button once. The temperature indicators will now display the new temperature setting. Press and release the **COOLER** button until you have reached the desired setting. **HOLDING DOWN THE BUTTON WILL NOT CONTINUE TO LOWER THE SETTING.** The button must be pressed and released for each temperature change desired.

**To increase the temperature**, press and release the **HOTTER** button once. The temperature indicators will now display the new temperature setting. Press and release the **HOTTER** button until you have reached the desired setting. **HOLDING DOWN THE BUTTON WILL NOT CONTINUE TO RAISE THE SETTING.** The button must be pressed and released for each temperature change desired.

To maximize the efficiency of this water heater and reduce the risk of scalding, it is recommended that the gas control be set at the setting below the large triangle («▼»), which represents approximately 120°F (49°C).

2. When you have completed setting the control, wait thirty (30) seconds to see that the temperature indicators go off and the control enters “Sleep” mode. **ALL OF THE TEMPERATURE INDICATORS WILL BE OFF DURING NORMAL OPERATION.** If at any time you see the indicators on, there may be a problem with the water heater and you should consult the Troubleshooting Guide of this document, or contact a trained service professional.

Figure 17

DISPLAY						APPROXIMATE TEMPERATURE °F (°C)	APPROXIMATE TIME TO CAUSE INJURY
▼	A	B	C				
●	○	○	○	○	○	70 (21) (Vacation)	N/A
○	●	○	○	○	○	110 (43)	5 Minutes
○	○	●	○	○	○	115 (46)	
○	○	○	●	○	○	120 (49)	
○	○	○	○	●	○	125 (52)	30 Seconds
○	○	○	○	○	●	130 (54)	
○	○	○	○	○	○	135 (57)	5 Seconds
○	○	○	○	○	○	140 (60)	
○	○	○	○	○	○	145 (63)	1.5 Seconds
○	○	○	○	○	○	150 (66)	
○	○	○	○	○	○	160 (71)	Under 1 Second

FLASHING →

# GENERAL MAINTENANCE

When hot water is drawn from the tank in frequent short bursts, a condition known as “stacking” is created. “Stacking” is the result of increased cycling of the burner and can produce very hot water temperatures at the hot water outlet. Always remember to check the hot water coming out of any faucet with your hand before use. This will reduce the risk of scalding-related injuries.

The gas control pictured in this manual is equipped with a resettable type automatic high temperature cut-off. Should the temperature of the water exceed 195°F (91°C), the high temperature cut-off will automatically shut off the gas supply to the water heater. If this situation occurs, the gas control must be reset by a qualified service technician.

## ⚠ WARNING

Should overheating occur or the gas supply fail to shut-off, close the gas supply manual shut-off valve. Failure to follow this instruction can result in property damage, personal injury, or death.

### Out of Fuel

If your water heater should run out of gas, proceed as follows:

- 1) Toggle the “ON/OFF” switch located on the gas control to the “OFF” position.
- 2) Unplug the power cord from the wall socket.
- 3) Close the gas supply manual shut-off valve.
- 4) Once the gas supply has been re-established, proceed to the **Operating Instructions**.

### Housekeeping

Keep the area around the water heater clean and free of dust, lint, and dirt. Make sure that all of the minimum clearances to combustible materials are being maintained.

## ⚠ WARNING

**DO NOT** store or use gasoline or other flammable vapours and liquids around the water heater.

**DO NOT** put or store any objects on the top of the water heater. Failure to follow these instructions can result in property damage, personal injury, or death.

### Flammable Vapour Sensor

This water heater is equipped with a flammable vapour sensor (FV) that will shut it down in the event of a flammable vapour incident. It is a safety feature that may prevent property damage, personal injury, or death.

The FV sensor is located on the front left bottom of the exterior casing of the water heater. The FV sensor is protected from shock and contaminants by a robust plastic cover. The function of the FV sensor is to detect the presence of flammable vapours before they enter the combustion chamber and ignite. If the FV sensor detects the presence

of flammable vapours while the water heater is operating, the gas control will switch to lock-out mode and the water heater will shut down. If the water heater is not operating when the flammable vapours are detected, the control will switch to lock-out mode and prevent the water heater from lighting.

After a flammable vapour incident has occurred and the flammable vapours have dissipated, the FV sensor is designed to automatically reset itself. The Intelli-Vent™ gas control however, will have gone into lock-out mode and will need to be manually reset. A qualified service technician must be called to determine if flammable vapours entered the combustion chamber and ignited. In most instances, there will not have been ignition of flammable vapours inside the combustion chamber because the FV sensor will have detected these vapours and shut down the water heater. In this case, the Intelli-Vent™ gas control can be reset and the water heater may resume normal operation. On the other hand, if the flammable vapours ignited inside the combustion chamber, the water heater may need to be replaced. The technician will be able to determine whether or not the water heater needs to be replaced based on the amount of flammable vapours that entered the combustion chamber and the damage to the water heater from the resulting fire.

### Condensation

As moisture from the products of combustion comes into contact with the cold surface of the inner tank, it may condense. This situation will usually occur:

- 1) When the water heater is filled with cold water for the first time.
- 2) If the water heater has been undersized.
- 3) When large amounts of hot water are drawn from the water heater in a short period of time, and the refill water is very cold.

Due to the high-efficiency rating of this gas-fired water heater, it may produce more condensation than older models. Condensation forming on the flue tube will drop on the burner making a “sizzling” sound. This condition is not uncommon and must never be misinterpreted as a leaking tank. It will disappear once the water becomes heated.

Because of the large amounts of water that can condense, it is very important that a drain pan be installed under the water heater (**refer to Figure 8**). **Under no circumstances is the manufacturer to be held liable for any water damage, in connection with this water heater.** If the problem does not go away and water continues to drip after the water heater has heated up, check all of the plumbing connections to make sure they are not leaking.

# GENERAL MAINTENANCE

## Burner Ignitor Assembly

Every three (3) months, check the burner and flame ignitor assembly. Remove the outer access door and look through the sight glass to examine the flames. A soft blue flame indicates proper gas combustion. A yellow tipped flame indicates poor combustion. With a vacuum cleaner, remove any dust, lint, and dirt accumulation on or around the combustion chamber.

## Temperature and Pressure-Relief Valve

Manually operate the temperature and pressure-relief valve at least once a year, standing clear of the outlet to avoid being burned. Lift and release the operating lever on the valve to make it operate freely. If, after manually operating the valve, it fails to completely reset itself and continues to discharge water, replace it with a new one.

## Venting System Inspection

The venting system must be thoroughly inspected once a year. Check the venting system to make sure that all of the connections are securely fastened, and that all of the joints are properly sealed. If any part of the venting system is damaged, it must be replaced by a qualified service technician.

## Anode

### ⚠ WARNING

The cap covering the anode on top of the water heater **MUST BE** put back in place after servicing the anode.

This water heater is equipped with an anode that is designed to prolong the life of the glass-lined tank. The anode is slowly consumed, protecting the glass-lined tank from corrosion. The anode should be checked every two (2) years. If more than half of the anode has been consumed, it should be replaced. Instructions on how to change the anode can be obtained from the manufacturer.

The life expectancy of the water heater is reduced where a water softener is introduced to fight hard water, because the sodium salts added by a softener make this water extremely conductive. Under these conditions, the magnesium anode must be replaced by an aluminum anode approved by the manufacturer, along with the addition of zinc pellets.

In certain water conditions, the magnesium anode will react with the water, producing discoloured or smelly water. The most common complaint is hot water that smells like rotten eggs. This phenomenon is the result of the reaction between the magnesium anode and hydrogen sulfide gas dissolved in the water, which occurs frequently in well systems. This problem can usually be eliminated or reduced by changing the anode to aluminum anode combined with zinc pellets and by chlorinating the water heater and the plumbing system. If the problem persists, special filtration equipment may be required. Under no circumstances is the anode to be removed from the water

heater on a permanent basis. **Removal of the anode will lead to premature failure of the water heater and void the warranty.**

### ⚠ WARNING

Hydrogen gas can be produced in a hot water system that has not been used for a long period of time (generally two [2] weeks or more). **HYDROGEN GAS IS EXTREMELY FLAMMABLE.** It is highly recommended to open the hot water faucet in the kitchen for several minutes before you use any electrical appliances connected to the hot water system, such as a dishwasher or washing machine. If hydrogen gas is present, there will be an unusual sound, such as air escaping through the pipe, as the hot water faucet is opened. **DO NOT** smoke or introduce an open flame near the faucet when it is opened.

## Draining the Water Heater

Drain a pail of water through the drain valve at least once a year. This will remove excess sediment from the bottom of the tank. This sediment, if allowed to accumulate, will reduce the efficiency and the life of the tank.

To completely drain the water heater:

- 1) Toggle the "ON/OFF" switch located on the gas control to the "OFF" position.
- 2) Unplug the power cord from the wall socket.
- 3) Close the gas supply manual shut-off valve.
- 4) Close the cold water supply manual shut-off valve.
- 5) Connect one end of a garden hose to the water heater drain valve and put the other next to a free-flowing drain.
- 6) Open the drain valve by inserting a flat-head screwdriver into the slot on the head of the drain valve and turn the knob counterclockwise .
- 7) Open a hot water faucet to allow air into the system.

## Vacation

If you are planning a vacation or other prolonged absence, it is highly recommended to shut-off the gas supply and the cold water supply to the water heater. This will save energy, protect against property damage in the event the water heater leaks, and prevent the build-up of hydrogen gas. If the water heater and piping are exposed to freezing temperatures, they should both be drained.

Remember to check the water heater thoroughly after it has been shut-off for an extended period of time before putting it back in operation. Make sure that the water heater is completely full of water, and that the cold water supply manual shut-off valve is open, before lighting the burner.

# GENERAL MAINTENANCE

## Service Procedure

If you are experiencing problems with your water heater, follow these three easy steps:

- 1) Consult the **Troubleshooting Guide** contained in this manual (**see Page 24**). It lists the most common problems experienced with your gas-fired water heater. The solutions you find listed may provide a quick and simple solution to your problem and save you time and money.
- 2) If the solution listed in the Troubleshooting Guide does not solve the problem or if your particular problem is not listed in the guide, contact the installer of the water heater, or the local gas utility.
- 3) If you still cannot solve the problem, contact the manufacturer's Customer Service Department by e-mail at **service@giantinc.com** or toll free at **1-800-363-9354** (option 1). To help serve you in a quick and efficient manner, **always have the following information ready:**
  - a) **Model number.**
  - b) **Serial number.**
  - c) **Date of installation.**
  - d) **Where the water heater was purchased.**
  - e) **Complete address where the water heater is installed.**
  - f) **A description of the problem.**

# REPLACEMENT PARTS

Item	Description
1	Gas control assembly
1a	Gas control electronic module
1b	Gas control body
2	Flammable Vapour Sensor
3	Protective Cover
4	Ignitor Assembly
5	Burner Assembly
6	Inner Access Doors
7	Outer Access Door
8	Brass Drain Valve
9	Overflow Tube
10	Closed end dip tube with heat trap
11	Magnesium Anode
12	Temperature & Pressure-Relief Valve
13	Flue Baffle
14	Inlet Rubber Adaptor
15	Vacuum Switch - Inlet
16	Vacuum Switch - Outlet
17	High Limit Switch
18	Rubber transition fitting
19	Blower Assembly
20	Outlet Nipple with heat trap

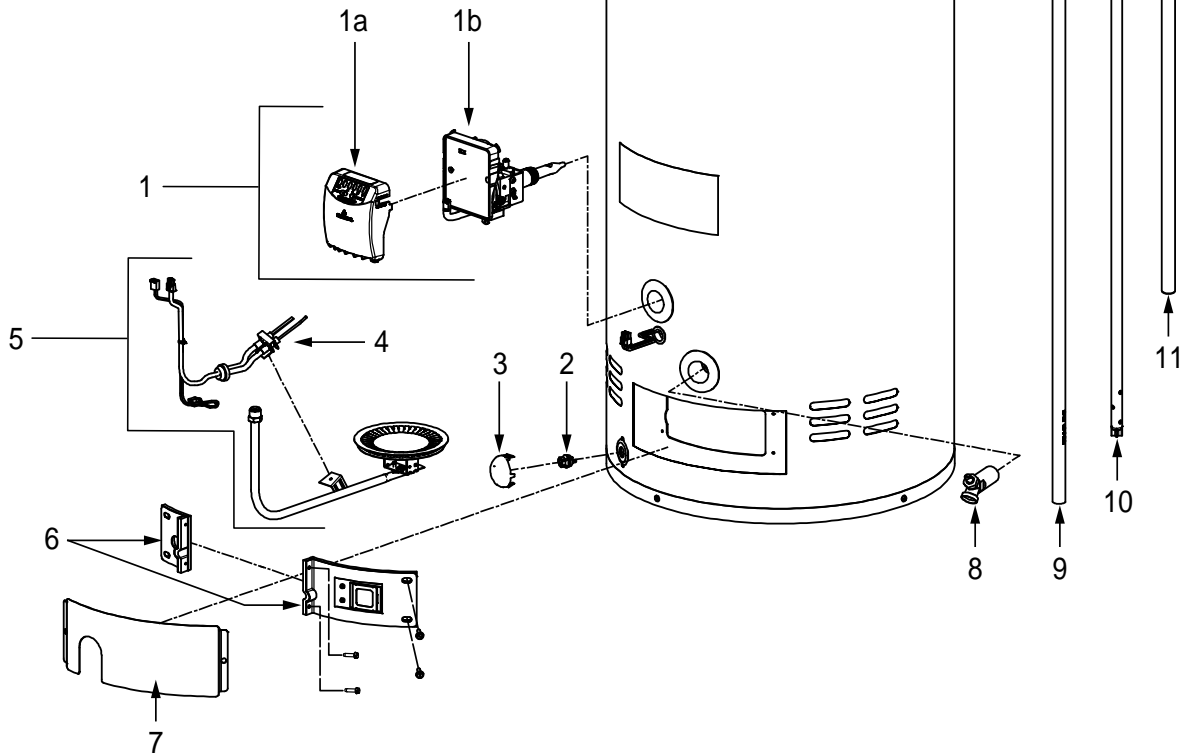
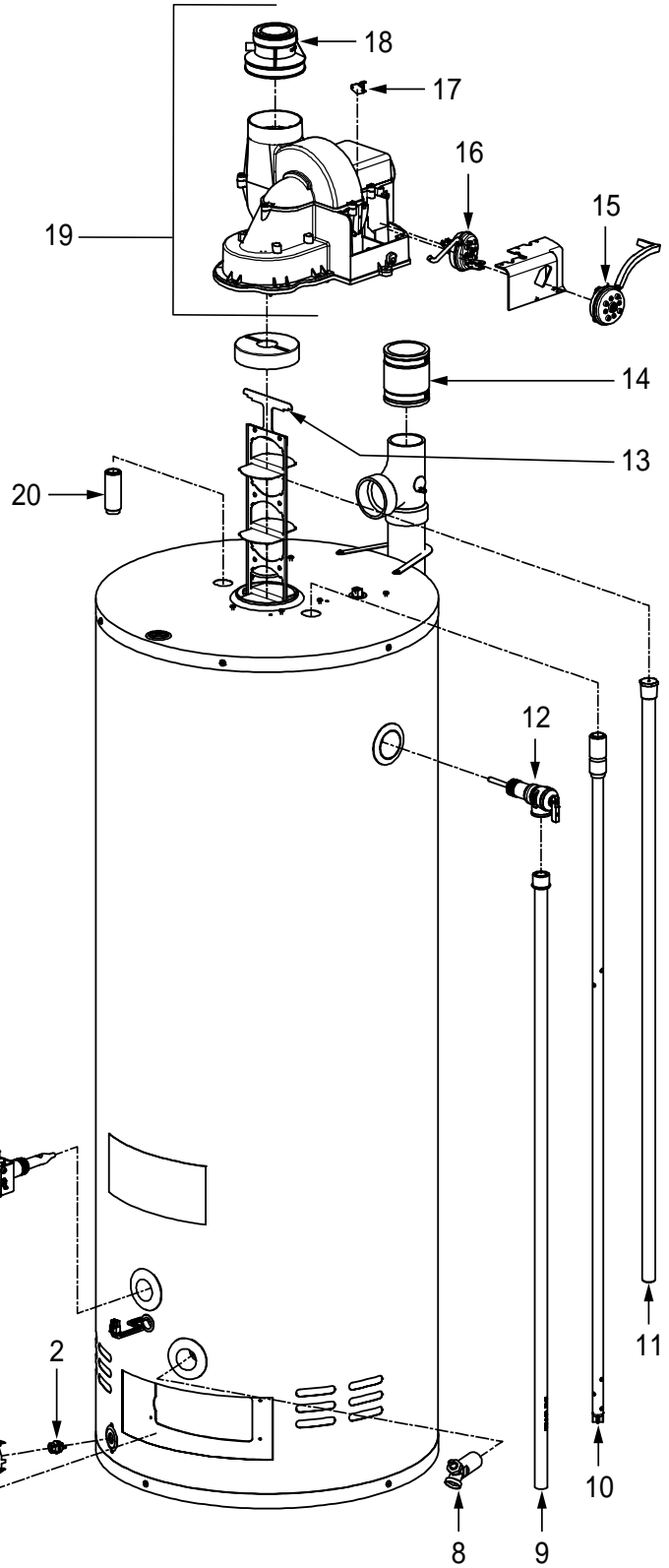

# TROUBLESHOOTING GUIDE

## ⚠ WARNING

Disconnect the electrical power before servicing the water heater. Service should only be performed by a qualified service technician. Failure to follow these instructions can result in personal injury and/or death.

CONDITION (code#)	CAUSE	CORRECTIVE ACTION
 <b>1</b>	An open earth ground circuit to the ignition.	<ol style="list-style-type: none"> <li>1) Check that the earth ground conductor is properly connected at the fuse box or breaker panel and the water heater.</li> <li>2) Check that the grounding conductors on the water heater are properly connected and secure.</li> </ol>
 <b>2</b>	A wiring error or a high resistance to earth ground.	<ol style="list-style-type: none"> <li>1) Check for proper connection of the line neutral and line hot wires.</li> <li>2) Check that the water heater is securely connected to earth ground.</li> </ol>
 <b>3</b>	The pressure switch remained closed longer than 5 seconds after the call for heat began.	<ol style="list-style-type: none"> <li>1) The pressure switch wiring is incorrect.</li> <li>2) The pressure switch is defective and must be replaced.</li> </ol>
 <b>4</b>	The pressure switch remained open longer than 5 seconds after the power vent was energized. (see note at the bottom of the page)	<ol style="list-style-type: none"> <li>1) The pressure switch wiring is incorrect.</li> <li>2) The pressure switch tubing is not properly connected.</li> <li>3) There are obstructions or restrictions in the water heater air intake or exhaust flue.</li> </ol>
 <b>5</b>	The self diagnosing test has detected an error in the hot surface ignitor circuit.	<ol style="list-style-type: none"> <li>1) Check the wiring is correct and secure.</li> <li>2) Disconnect the ignitor connector and measure the ignitor resistance with an accurate ohmmeter between pins 1 and 2. Resistance should be between 11.5 and 18.8 ohms. If the reading is incorrect, replace the hot surface ignitor.</li> <li>3) If the above checks are good, replace the gas control.</li> </ol> 
 <b>6</b>	The maximum number of ignition retries or recycles has been reached and the system is in lock-out mode.	<ol style="list-style-type: none"> <li>1) Check if the gas supply is off or too low to operate.</li> <li>2) Check the flame sensor rod to see if it is located properly and free from contamination. Reposition the flame sensor rod or lightly clean it with an abrasive cloth.</li> <li>3) The hot surface ignitor may not be positioned correctly. Reposition as necessary.</li> <li>4) Check that the hot surface ignitor and flame sensor rod are wired correctly and in good working condition.</li> <li>5) Low voltage to the water heater. Check and repair.</li> </ol>
 <b>7</b>	The gas valve driver circuit.	<ol style="list-style-type: none"> <li>1) Turn off the power to the water heater for 10 seconds and then back on.</li> <li>2) If the above step did not clear the error, replace the gas control.</li> </ol>
 <b>8</b>	The internal microcomputer.	<ol style="list-style-type: none"> <li>1) Turn off the power to the water heater for 10 seconds and then back on.</li> <li>2) If the above step did not clear the error, replace the gas control.</li> </ol>
 <b>9</b>	The internal circuit.	<ol style="list-style-type: none"> <li>1) Turn off the power to the water heater for 10 seconds, verify the polarity and then back on</li> <li>2) If the above step did not clear the error, replace the gas control.</li> </ol>
 <b>10</b>	Flame signal sensed out of proper sequence.	Replace the gas control.
 <b>11</b>	The high temperature thermal cut-off is open.	Replace the gas control.
 <b>12</b>	One of the temperature adjust buttons is stuck closed.	<ol style="list-style-type: none"> <li>1) Make sure that there are no objects leaning against the front of the control.</li> <li>2) Lightly press and release each of the buttons once.</li> <li>3) If the above actions do not clear the error, the control will continue to regulate the water temperature at the last setting, but you will not be able to change settings unless you replace the gas control.</li> </ol>
 <b>13</b>	The water temperature sensor is either open or short-circuited.	<ol style="list-style-type: none"> <li>1) Check that all of the wiring is correct and that there are no open or short circuits.</li> <li>2) If no wiring problems are found, the gas control must be replaced.</li> </ol>
 <b>14</b>	The self-diagnosing test found a problem with the flammable vapour sensor.	<ol style="list-style-type: none"> <li>1) Check that all wiring is correct and that there are no open or short circuits.</li> <li>2) If no wiring problems are found, the flammable vapour sensor must be replaced.</li> </ol>
 <b>15</b>	The control detected the presence of flammable vapours near the appliance and entered lock-out mode.	<ol style="list-style-type: none"> <li>1) Identify the source of the flammable vapours and remove it from the area surrounding the water heater.</li> <li>2) Contact a service technician to have the water heater inspected immediately.</li> </ol>
 <b>16</b>	Weak Flame Current.	<ol style="list-style-type: none"> <li>1) Check that the flame sense rod to see if it is properly located and free from contamination. Reposition the flame sense rod or lightly clean with an abrasive cloth.</li> <li>2) Low voltage to the water heater. Check and repair.</li> </ol>

**Note for models with a manual reset only:** Since the high limit switch on the blower is in series with the pressure switch, the problem could be that the high limit switch tripped. Reset the high limit Switch by pressing on the red button in the middle of the switch.



# TROUBLESHOOTING GUIDE

<b>CONDITION</b>	<b>CAUSE</b>	<b>CORRECTIVE ACTION</b>
<b>The burner will not ignite.</b>	No gas.	Check with gas utility company.
	Dirt in gas line.	Notify utility. Install drip leg in gas line.
	Air intake terminal is blocked.	Check outside for debris in the terminal or frozen air intake terminal and remove.
	Main burner line clogged.	Clean. Check for source of trouble and correct.
	Defective flame sensor.	Replace with new flame sensor.
	Defective gas control.	Replace with new gas control.
	Gas control set too low.	Turn temperature dial to desired temperature.
<b>The burner flame floats and lifts off ports.</b>	High gas pressure.	Check with gas utility company.
	Orifice too large.	Replace with correct orifice.
	Flue clogged.	Clean. Check for source of trouble and correct.
	Air intake terminal is blocked.	Check outside for debris in the terminal and remove.
	Cold drafts (downdraft).	Locate source and correct.
<b>The burner flame is yellow and lazy.</b>	Insufficient secondary air.	Check that the air intake terminal is not blocked.
	Flue clogged.	Clean. Check for source of trouble and correct.
	Air intake terminal is blocked.	Check outside for debris in the terminal and remove.
	Main burner line clogged.	Clean. Check for source of trouble and correct.
<b>The burner flame is too high.</b>	Insufficient secondary air.	Check that the air intake terminal is not blocked.
	Orifice too large.	Replace with correct orifice.
	Defective gas control.	Replace with new gas control.
<b>The flame burns at the orifice.</b>	Low gas pressure.	Check with gas utility company.
	Defective gas control.	Replace with new gas control.
<b>High operating costs.</b>	Gas control set too high.	Turn temperature dial to desired temperature.
	Sediment or lime in tank.	Drain. Check to see if water treatment is necessary.
	Water heater is undersized.	Install size of water heater that meets demand.
	Wrong piping connections.	Correct piping, dip-tube must be in cold inlet.
	Leaking faucets.	Repair faucets.
	Gas leaks.	Check with gas utility company. Repair at once.
	Wasted hot water.	Advise consumer.
	Long runs or exposed piping.	Insulate piping.
Hot water piping on outside wall.	Insulate piping.	
<b>Insufficient hot water.</b>	Low gas pressure.	Check with gas utility company.
	Wrong piping connections.	Correct piping, dip-tube must be in cold inlet.
	Sediment or lime in tank.	Drain. Check to see if water treatment is necessary.
	Water heater is undersized.	Install the size of water heater that meets the demand.
	Gas control set too low.	Turn temperature knob to desired temperature.
	Leaking faucets.	Repair faucets.
	Wasted hot water.	Advise consumer.
	Long runs or exposed piping.	Insulate piping.
Hot water piping on outside wall.	Insulate piping.	
<b>Slow hot water recovery.</b>	Insufficient secondary air.	Check that the air intake terminal is not blocked.
	Low gas pressure.	Check with gas utility company.
	Gas control set too low.	Turn temperature dial to desired temperature.
	Improper calibration.	Replace gas control.
	Flue clogged.	Clean. Check for source of trouble and correct.
	Water heater is undersized.	Install size of water heater that meets demand.
	Wrong piping connection.	Correct piping, dip-tube must be in cold inlet.
Wasted hot water.	Advise consumer.	

# TROUBLESHOOTING GUIDE

<b>CONDITION</b>	<b>CAUSE</b>	<b>CORRECTIVE ACTION</b>
<b>Leaking water.</b>	Poorly sealed, hot or cold water connections, gas control threads, relief valve, or drain valve.	Tighten threaded connections.
	Leakage from plumbing system or other appliances.	Inspect plumbing system and other appliances.
	Condensation.	Refer to Condensation.
<b>Water drips from the relief valve.</b>	Heater stacking.	Lower gas control setting.
	Excessive water pressure.	Install a pressure-reducing valve.
	Thermal expansion in a closed water system.	Install an expansion tank.
	Improperly seated valve.	Check relief valve works properly and replace, if necessary.
<b>The gas control fails to shut off.</b>	Defective gas control.	Replace with new gas control.
	Improper calibration.	Replace gas control.
<b>Condensation.</b>	Water heater filled for first time.	Let water heater warm up. Problem should go away. If it persists, check all plumbing connections for leaks.
	Heavy draws of hot water with very cold refill water.	Let water heater warm up. Problem should go away. If it persists, check all plumbing connections for leaks.
	Water heater is undersized.	Install size of water heater that meets demand.
<b>Combustion odours.</b>	Insufficient secondary air.	Check that the air intake terminal is not blocked.
	Flue clogged.	Clean. Check for source of trouble and correct.
<b>Smoking and carbon formation (sooting).</b>	Insufficient secondary air.	Check that the air intake terminal is not blocked.
	Low gas pressure.	Check with gas utility company.
	Burner flame yellow, lazy.	Refer to <i>The burner flame is yellow and lazy.</i>
	Flue clogged.	Clean. Check for source of trouble and correct.
	Defective gas control.	Replace with new gas control.
<b>Smelly water.</b>	High sulfate or mineral content in water.	Change magnesium anode to an aluminum anode and bleach tank.

# MODEL DIMENSIONS

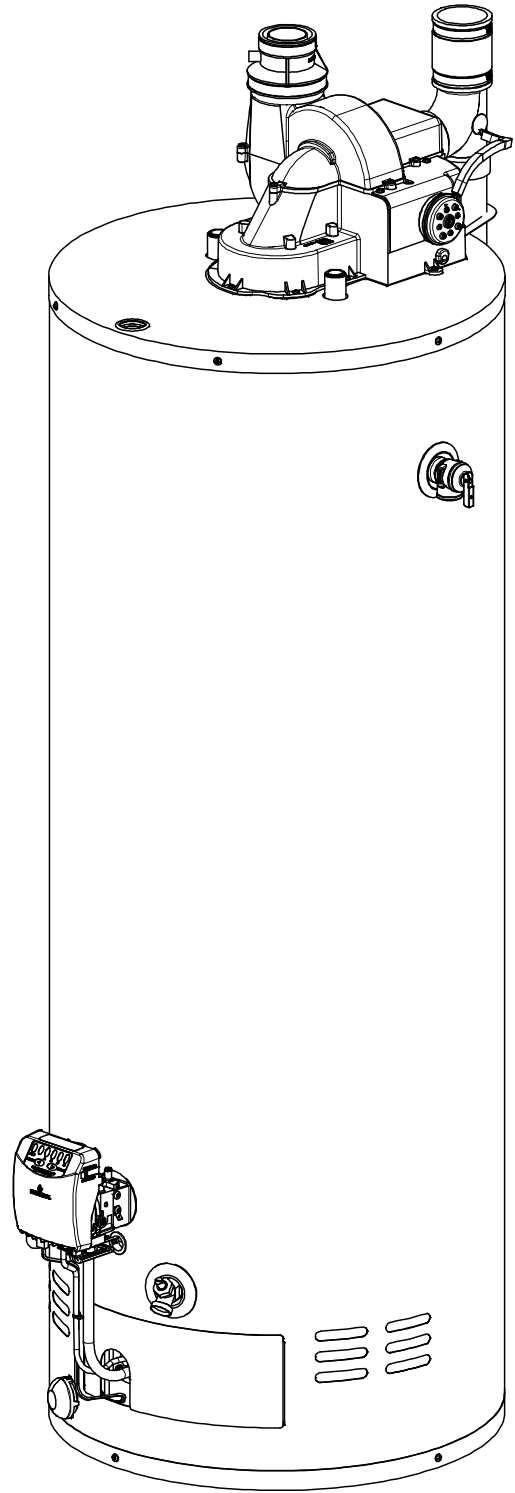
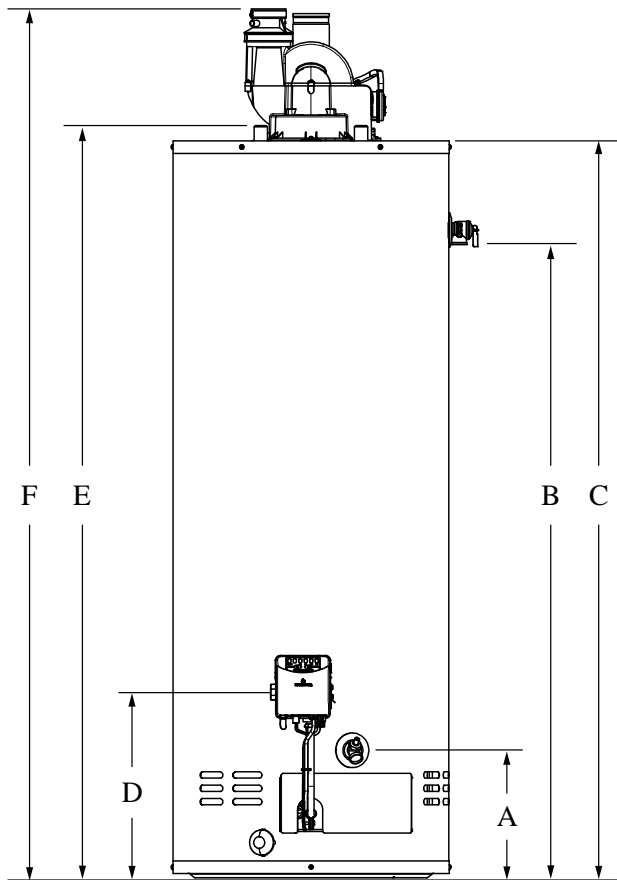
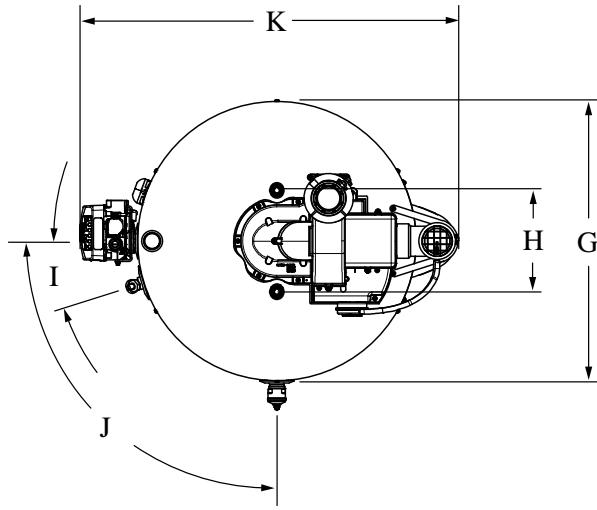

## Dimensions inches (cm)

Models	A	B	C	D	E	F	G	H	I	J	K
All UG40	9 3/8 (24)	51 1/2 (131)	60 (153)	14 3/4 (37)	61 1/4 (156)	70 1/2 (179)	20 (51)	8 (20)	19.5°	90.0°	29 (74)
All UG50	9 3/8 (24)	50 3/8 (128)	58 5/8 (149)	14 3/4 (37)	59 3/4 (152)	69 (175)	22 (56)	8 (20)	17.4°	90.0°	29 7/8 (76)
All UG60	9 3/8 (24)	50 1/4 (128)	58 5/8 (149)	14 3/4 (37)	60 1/8 (153)	69 1/8 (176)	24 (61)	8 (20)	15.6°	90.0°	32 (81)



Enhancing everyday living

# STANDARD BASIC LIMITED WARRANTY

ON RESIDENTIAL ELECTRIC, GAS-FIRED WATER HEATERS AND STORAGE TANKS  
(Hereunder referred to as "Unit" or "Equipment")

## GENERAL

The manufacturer warrants that, subject to verification of your warranty claim within the warranty period described below, the necessary corrective actions will be taken to either repair or replace the defective unit or component part subject to the terms and conditions outlined in this document. Furthermore, any replacement unit or component part supplied under warranty will carry only the warranty remaining portion, based on the original unit installation date. However, the warranty is limited to one (1) replacement unit. If due to some unusual circumstance, a replacement unit or component part is found to be defective by our inspection department, another unit or component part will be provided in order to fulfill the obligation of the original warranty. This warranty applies only to the original owner that purchased the unit, to the unit original installation location, and it is not transferable. In order to benefit from this warranty, the warranty reply card must be completed and sent back to GIANT within forty-five (45) days of the unit purchase date, otherwise the warranty will be as follows: SIX (6) years (for a residential water heater in a family dwelling), FIVE (5) years (for a storage tank in a family dwelling) and ONE (1) year (for any installation other than a family dwelling) from the manufacturing date, without exception.

## THE INNER TANK

If the warranty card is returned within the applicable time frame and the inner tank leaks within the shorter of the two following periods: SIX (6) years after the original installation date or NINETY (90) months after the manufacturing date, whichever comes first, a replacement unit will be provided to the original unit owner. Use of the equipment for purposes other than for a family dwelling limits the warranty to ONE (1) year.

### Exceptions:

- 1 : Or FIVE (5) years for storage tanks
- 2 : Or SEVENTY-EIGHT (78) months for storage tanks

## COMPONENT PARTS

If any component part is found to be defective within ONE (1) year from the original installation date, provided said defective part is an in-house factory made piece or an original factory approved OEM piece, the manufacturer will provide a replacement part after the receipt and testing of such part.

## THIS WARRANTY DOES NOT APPLY IN THE FOLLOWING CASES:

- 1) To defects or malfunctions resulting from failure to properly install, operate, or maintain the unit in accordance with the Owner's Manual.
- 2) If the installation does not comply with CSA Standards, in particular, but not limited to, the existing CAN/CSA-C652 Standard (*Installation of Electric Storage Tank and Heat Pump Water Heaters for Residential Use*), CSA B149.1 (*Natural gas and propane installation code*) as well as any other existing codes or standards, local regulations CAN/CSA-C22.1 (*Canadian Electrical Code*), and good practices.
- 3) To any damage or failure caused by abuse, fire, floods, freezing, or other acts of God.
- 4) To any damage or failure caused by operating the unit without an approved temperature & pressure-relief valve having been installed.
- 5) To any damage or failure caused by powering any energy source while the equipment is empty or partially empty or contains sediment build-up resulting in dry firing of the heating elements.

- 6) To any damage or failure caused by connecting the unit to any other source of energy not approved by GIANT or by operating the equipment for other use than with potable water without any additives such as salt, chlorine, or chemicals other than those added for the purpose of rendering the water fit to drink.
- 7) To any damage or failure caused by the removal of the anode and/or by not assuring that there is a working anode in the unit at all times.

**"All anodes must be checked at least once every two (2) years & replaced, if necessary"**. The installation of an anode that does not comply with the requirements of the existing CAN/CSA-C309 Standard (*Performance Requirements for Glass-Lined Storage Tanks for Household Hot Water Service*), particularly in regards to the manufacturing, installation, and composition of the replacement anode, will instantly void the warranty. The same applies, but is not limited to, the non-compliance of the CAN/CSA-C191, CAN/CSA-C22.2, and CSA B149.1 Standards.

- 8) To any damage or failure caused by the use of the unit with a water softener if the magnesium anode has not been replaced by an aluminum anode approved by GIANT, as well as the addition of zinc pellets.
- 9) To any damage or failure caused by having affixed to the unit any non-factory made or factory approved replacement part(s), such as elements, controls, dip-tubes, anode, induced-current anode, relief valves, etc.

- 10) To any damage caused by not having the unit installed adjacent to a free-flowing drain or in a pan or basin connected to such free-flowing drain.
- 11) For all equipment operated at water temperatures exceeding the maximum operating setting of the thermostat and/or the high limit control, at a pressure exceeding the one listed on the rating plate, for equipment subject to a water-hammer effect that reverses the bottom of the tank, units that are installed in a closed-looped system without any adequate expansion tank<sup>3</sup> being installed as well as equipment installed in a system equipped with a backflow preventer, a pressure-reducing valve, or any other device, such as a check valve, without an adequate expansion tank<sup>3</sup> being installed.

- 3 : Or any other method accepted by the competent authority
- 12) To any unit drained for wintering purposes.
- 13) To any performance issue caused by the poor selection of equipment, power supply, wiring, or fuse / breaker.
- 14) To any unit from which the rating plate has been removed or altered.
- 15) To any break or damage caused by a water-hammer effect coming from, but not limited to, a quick-closing valve, a solenoid valve, or any other valves without an adequate pre-fabricated expansion tank being installed in compliance with existing codes, standards, and good practices.
- 16) To any issue caused by the installation of water connections not compatible with the equipment inlet and outlet "NPT" connections.
- 17) To any unit installed outside of Canada or the United States.

## SERVICE LABOUR RESPONSIBILITY

This warranty does not cover any labour expense for diagnostic, service, removal, or re-installation of a replacement unit. All such expenses are the responsibility of the unit owner.

## SHIPPING COSTS

If a unit or component part is deemed to be replaced, the manufacturer will pay the transportation costs to ship said replacement unit or part to a convenient authorized distributor or retailer of our choice. The unit owner must pay for any local cartage including the cost of returning the replaced unit or component part to the authorized distributor or retailer.

## CLAIM PROCEDURE

Any claim covered by the warranty must be made to GIANT within a maximum of thirty (30) days from the date the defect is first discovered. Failure to provide a written notice for such defect to the manufacturer within the allocated time frame will void the warranty. Any claim for warranty service should be made with your contractor, wholesaler, or retailer from whom the unit was purchased. In turn, said contractor, wholesaler, or retailer will contact the manufacturer. If this procedure cannot be followed, please contact a local contractor, wholesaler, or retailer distributing our products. For further warranty information, please call our customer service department at (514) 645-8893 or 1-800-363-9354, option 1. In order to answer your call promptly, prior to calling the factory, please make sure to have handy the unit model and serial number that is found on the rating plate, on the side of the unit. Proof of purchase showing the date and name of the business from whom the unit was purchased is mandatory if the manufacturing date goes beyond the warranty period offered by the manufacturer.

If an exact replacement unit is unavailable for whatever reason such as, but not limited to, changes in government standards, the manufacturer agrees to provide a unit or component part with comparable features. If government regulations or industry standards require the replacement unit or component part to have features not found on the defective unit or component part, the unit owner will be charged the difference in price associated with these required features. If such owner pays the difference in price for these required features, they will benefit from a complete new Standard Basic Limited Warranty for the replacement unit.

## MISCELLANEOUS

No one is authorized to modify any conditions of this actual warranty. The manufacturer will not honour any other warranty of any kind other than what is offered. No claims for incidental or consequential damage (including damage from leakage) will be accepted. If the warranty card is not returned to us, a proof of purchase showing the name, date, and location of the original point of purchase is mandatory to process any warranty claim. Failure to provide such documentation will result in the lesser of the warranty periods being offered, as stated in the "GENERAL" section. **In order to avoid any confusion and/or disputes, we suggest that the warranty card be completed and returned to us no later than forty-five (45) days after installation.**

## EXTENDED WARRANTY

For information concerning options for additional warranties on our residential electric, gas-fired water heaters and storage tanks, contact your local licensed plumber, an authorized retailer, or GIANT.



Enhancing everyday living

# STANDARD BASIC LIMITED WARRANTY FOR U.S. INSTALLATIONS

ON RESIDENTIAL ELECTRIC, GAS-FIRED WATER HEATERS AND STORAGE TANKS

(Hereunder referred to as "Unit" or "Equipment")

## GENERAL

The manufacturer warrants that, subject to verification of your warranty claim within the warranty period described below, the necessary corrective actions will be taken to either repair or replace the defective unit or component part subject to the terms and conditions outlined in this document. Furthermore, any replacement unit or component part supplied under warranty will carry only the warranty remaining portion, based on the original unit installation date. However, the warranty is limited to one (1) replacement unit. If due to some unusual circumstance, a replacement unit or component part is found to be defective by our inspection department, another unit or component part will be provided in order to fulfill the obligation of the original warranty. This warranty applies only to the original owner that purchased the unit, to the unit original installation location, and it is not transferable. In order to benefit from this warranty, the warranty reply card must be completed and sent back to GIANT within forty-five (45) days of the unit purchase date, otherwise the warranty will be as follows: SIX (6) years (for a residential water heater in a family dwelling), FIVE (5) years (for a storage tank in a family dwelling) and ONE (1) year (for any installation other than a family dwelling) from the manufacturing date, without exception.

## THE INNER TANK

If the warranty card is returned within the applicable time frame and the inner tank leaks within the shorter of the two following periods: SIX (6) years after the original installation date or NINETY (90) months after the manufacturing date, whichever comes first, a replacement unit will be provided to the original unit owner. Use of the equipment for purposes other than for a family dwelling limits the warranty to ONE (1) year.

### Exceptions:

- 1 : Or FIVE (5) years for storage tanks
- 2 : Or SEVENTY-EIGHT (78) months for storage tanks

## COMPONENT PARTS

If any component part is found to be defective within SIX (6) years from the original installation date, provided said defective part is an in-house factory made piece or an original factory approved OEM piece, the manufacturer will provide a replacement part after the receipt and testing of such part.

- 4 : Or ONE (1) year for storage tanks

## THIS WARRANTY DOES NOT APPLY IN THE FOLLOWING CASES:

- 1) To defects or malfunctions resulting from failure to properly install, operate, or maintain the unit in accordance with the Owner's Manual.
- 2) If the installation does not comply with existing Standards, in particular, but not limited to, the National Fuel Gas Code (ANSI Z223.1/NFPA 54), National Electrical Code (NFPA 70), National Standard Plumbing Code (NSPC), as well as any other existing codes or standards, local regulations, and good practices.
- 3) To any damage or failure caused by abuse, fire, floods, freezing, or other acts of God.

- 4) To any damage or failure caused by operating the unit without an approved temperature & pressure-relief valve having been installed.
- 5) To any damage or failure caused by powering any energy source while the equipment is empty or partially empty or contains sediment build-up resulting in dry firing of the heating elements.
- 6) To any damage or failure caused by connecting the unit to any other source of energy not approved by GIANT or by operating the equipment for other use than with potable water without any additives such as salt, chlorine, or chemicals other than those added for the purpose of rendering the water fit to drink.
- 7) To any damage or failure caused by the removal of the anode and/or by not assuring that there is a working anode in the unit at all times. **"All anodes must be checked at least once every two (2) years & replaced, if necessary".**
- 8) To any damage or failure caused by the use of the unit with a water softener if the magnesium anode has not been replaced by an aluminum anode approved by GIANT, as well as the addition of zinc pellets.
- 9) To any damage or failure caused by having affixed to the unit any non-factory made or factory approved replacement part(s), such as elements, controls, dip-tubes, anode, induced-current anode, relief valves, etc.
- 10) To any damage caused by not having the unit installed adjacent to a free-flowing drain or in a pan or basin connected to such free-flowing drain.

- 11) For all equipment operated at water temperatures exceeding the maximum operating setting of the thermostat and/or the high limit control, at a pressure exceeding the one listed on the rating plate, for equipment subject to a water-hammer effect that reverses the bottom of the tank, units that are installed in a closed-looped system without any adequate expansion tank<sup>3</sup> being installed as well as equipment installed in a system equipped with a backflow preventer, a pressure-reducing valve, or any other device, such as a check valve, without an adequate expansion tank<sup>3</sup> being installed.
- 3 : Or any other method accepted by the competent authority.

- 12) To any unit drained for wintering purposes.
- 13) To any performance issue caused by the poor selection of equipment, power supply, wiring, or fuse / breaker.
- 14) To any unit from which the rating plate has been removed or altered.
- 15) To any break or damage caused by a water-hammer effect coming from, but not limited to, a quick-closing valve, a solenoid valve, or any other valves without an adequate pre-fabricated expansion tank being installed in compliance with existing codes, standards, and good practices.
- 16) To any issue caused by the installation of water connections not compatible with the equipment inlet and outlet "NPT" connections.
- 17) To any unit installed outside of the United States.

## SERVICE LABOUR RESPONSIBILITY

This warranty does not cover any labour expense for diagnostic, service, removal, or re-installation of a replacement unit. All such expenses are the responsibility of the unit owner.

## SHIPPING COSTS

If a unit or component part is deemed to be replaced, the manufacturer will pay the transportation costs to ship said replacement unit or part to a convenient authorized distributor or retailer of our choice. The unit owner must pay for any local cartage including the cost of returning the replaced unit or component part to the authorized distributor or retailer.

## CLAIM PROCEDURE

Any claim covered by the warranty must be made to GIANT within a maximum of thirty (30) days from the date the defect is first discovered. Failure to provide a written notice for such defect to the manufacturer within the allocated time frame will void the warranty. Any claim for warranty service should be made with your contractor, wholesaler, or retailer from whom the unit was purchased. In turn, said contractor, wholesaler, or retailer will contact the manufacturer. If this procedure cannot be followed, please contact a local contractor, wholesaler, or retailer distributing our products. For further warranty information, please call our customer service department at (514) 645-8893 or 1-800-363-9354, option 1. In order to answer your call promptly, prior to calling the factory, please make sure to have handy the unit model and serial number that is found on the rating plate, on the side of the unit. Proof of purchase showing the date and name of the business from whom the unit was purchased is mandatory if the manufacturing date goes beyond the warranty period offered by the manufacturer.

If an exact replacement unit is unavailable for whatever reason such as, but not limited to, changes in government standards, the manufacturer agrees to provide a unit or component part with comparable features. If government regulations or industry standards require the replacement unit or component part to have features not found on the defective unit or component part, the unit owner will be charged the difference in price associated with these required features. If such owner pays the difference in price for these required features, they will benefit from a complete new Standard Basic Limited Warranty for the replacement unit.

## MISCELLANEOUS

No one is authorized to modify any conditions of this actual warranty. The manufacturer will not honour any other warranty of any kind other than what is offered. No claims for incidental or consequential damage (including damage from leakage) will be accepted. If the warranty card is not returned to us, a proof of purchase showing the name, date, and location of the original point of purchase is mandatory to process any warranty claim. Failure to provide such documentation will result in the lesser of the warranty periods being offered, as stated in the "GENERAL" section. **In order to avoid any confusion and/or disputes, we suggest that the warranty card be completed and returned to us no later than forty-five (45) days after installation.**





