



Enhancing everyday living



# ENGINEERING SUBMITTAL DATA SHEET

FFIR compliant residential direct vent  
natural & propane gas-fired water heaters

## UG60 MODELS

50 imperial gallons / 227 Litres  
insulated with 1 3/4" eco-friendly **GREENFOAM**

These models meet the safety and construction requirements of CSA 4.1 Standard and meet or exceed NRCan energy efficiency requirements

Models	Storage Capacity			Type of gas	Input BTU	Recovery 90 °F / 50 °C			E. F. Number	Altitude	Est. ship. weight lb (kg)
	(US) gal	Litres	Imp. gal			(US) gal	Litres	Imp. gal			
UG60-36MFDVF-P2U	60	227	50	LP	36,000	36.9	139	30.7	0.56	N & H	203 (92)
UG60-41MFDVF-P2U	60	227	50	LP	41,000	42.0	159	35.0	0.56	N	203 (92)
UG60-36MFDVF-N2U	60	227	50	N	36,000	36.9	139	30.7	0.56	N & H	203 (92)
UG60-41MFDVF-N2U	60	227	50	N	41,000	42.0	159	35.0	0.56	N	203 (92)

### DIMENSIONS inches (cm)

Models	A	B	C	D	E	F		G	H	I	J	K	L		M
						Min.	Max.						Min.	Max.	
All UG60	7 3/8 (18)	48 1/4 (123)	56 1/2 (144)	12 3/8 (31)	59 7/8 (152)	76 (193)	144 (366)	8 (20)	23 1/2 (60)	6 (15)	15.6°	90.0°	26 (66)	90 (229)	18 1/2 (47)

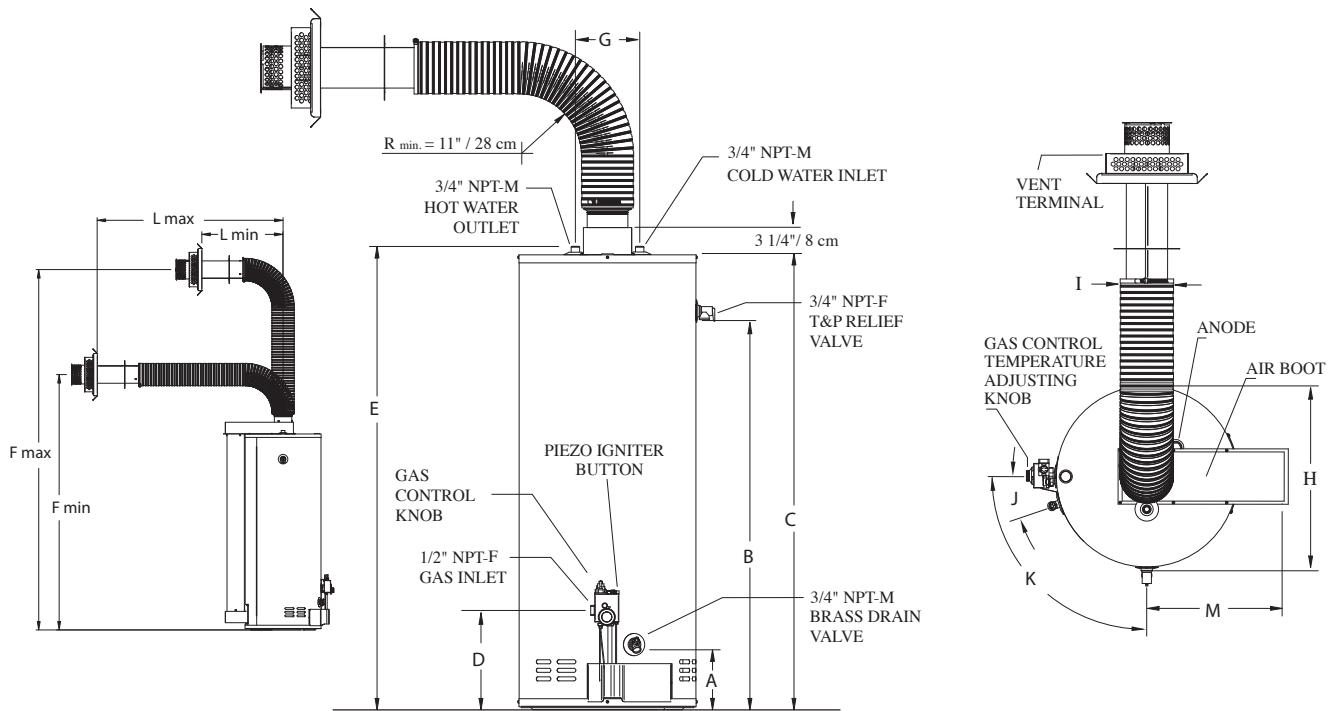

JOB TITLE \_\_\_\_\_

ADDRESS \_\_\_\_\_

CONTRACTOR \_\_\_\_\_

ADDRESS \_\_\_\_\_

ENGINEER \_\_\_\_\_

SUBMITTED DATE \_\_\_\_\_

REQUIRED PRODUCT \_\_\_\_\_

MODEL NO. \_\_\_\_\_ SIZE \_\_\_\_\_ QUANTITY \_\_\_\_\_

MODEL NO. \_\_\_\_\_ SIZE \_\_\_\_\_ QUANTITY \_\_\_\_\_

MODEL NO. \_\_\_\_\_ SIZE \_\_\_\_\_ QUANTITY \_\_\_\_\_

MODEL NO. \_\_\_\_\_ SIZE \_\_\_\_\_ QUANTITY \_\_\_\_\_

REQUIRED DATE \_\_\_\_\_

In accordance with our company policy of on-going product improvement, Giant Factories Inc. reserves the right to make changes without prior notice.

[giantinc.com](http://giantinc.com)



40 Lesage Avenue, Montréal-East (Québec) Canada H1B 5H3 • Telephone: (514) 645-8893 • Fax: (514) 640-0969