



Enhancing everyday living



# ENGINEERING SUBMITTAL DATA SHEET

Commercial electric water heaters, Flexible

**112 MODELS (Light & Medium Duty)**

99 imperial gallons / 450 litres

Insulated with 2" Eco-Friendly **GREENFOAM**

**208, 240, 277 & 480 Volts / Single phase**

These models meet the safety and construction requirements of CSA Standard C22.2 No. 110 and meet or exceed the standby loss requirements of NRCan and ASHRAE 90.1 Standard.

Models*	Input (kW)	Amperage				Phase	Number of elements
		208 Volts	240 Volts	277 Volts	480 Volts		
<b>Light Duty (2 elements) &amp; Medium Duty (4 elements)</b>							
1122Y-1-3S	3	14.4	12.5	10.8	6.3	1	2
1122Y-1-4.5S	4.5	21.6	18.8	16.2	9.4		
1122Y-1-5S	5	24.0	20.8	18.1	10.4		
1122Y-1-6S	6	—	25.0	21.7	12.5		
1124Y-1-6S	6	28.8	25.0	21.7	12.5	1	4
1124Y-1-9S	9	43.3	37.5	32.5	18.8		
1124Y-1-10S	10	48.1	41.7	36.1	20.8		
1124Y-1-12S	12	—	50.0	43.3	25.0		

\* Replace the "Y" by the letter referring to its voltage (refer to the following "Voltage index" as well as the "Model Number Structure" for further details).

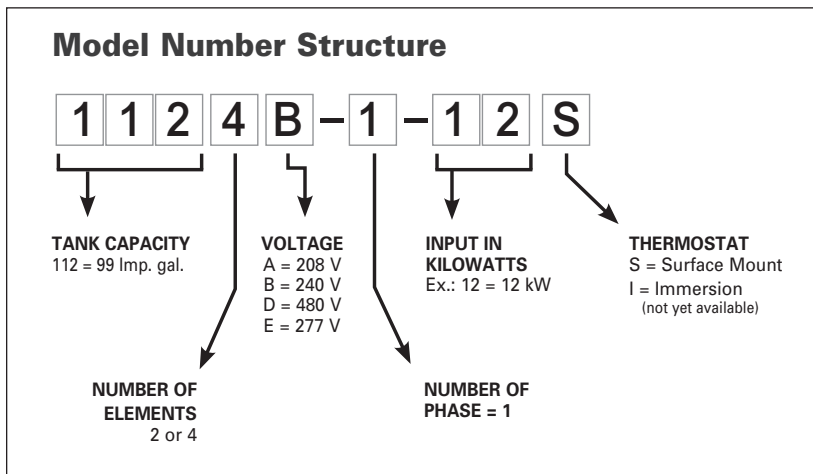

Voltage index	
A	208 Volts
B	240 Volts
D	480 Volts
E	277 Volts

Notes : \_\_\_\_\_

\_\_\_\_\_

\_\_\_\_\_

\_\_\_\_\_

\_\_\_\_\_

\_\_\_\_\_

\_\_\_\_\_

See reverse for this model drawing as well as order details.

In accordance with our company policy of on-going product improvement, Giant Factories Inc. reserves the right to make changes without prior notice.

[giantinc.com](http://giantinc.com)



40 Lesage Avenue, Montréal-East (Québec) Canada H1B 5H3 • Telephone: (514) 645-8893 • Fax: (514) 640-0969

Commercial electric water heaters, Flexible  
**112 MODELS**  
**(Light & Medium Duty)**  
 99 imperial gallons / 450 litres

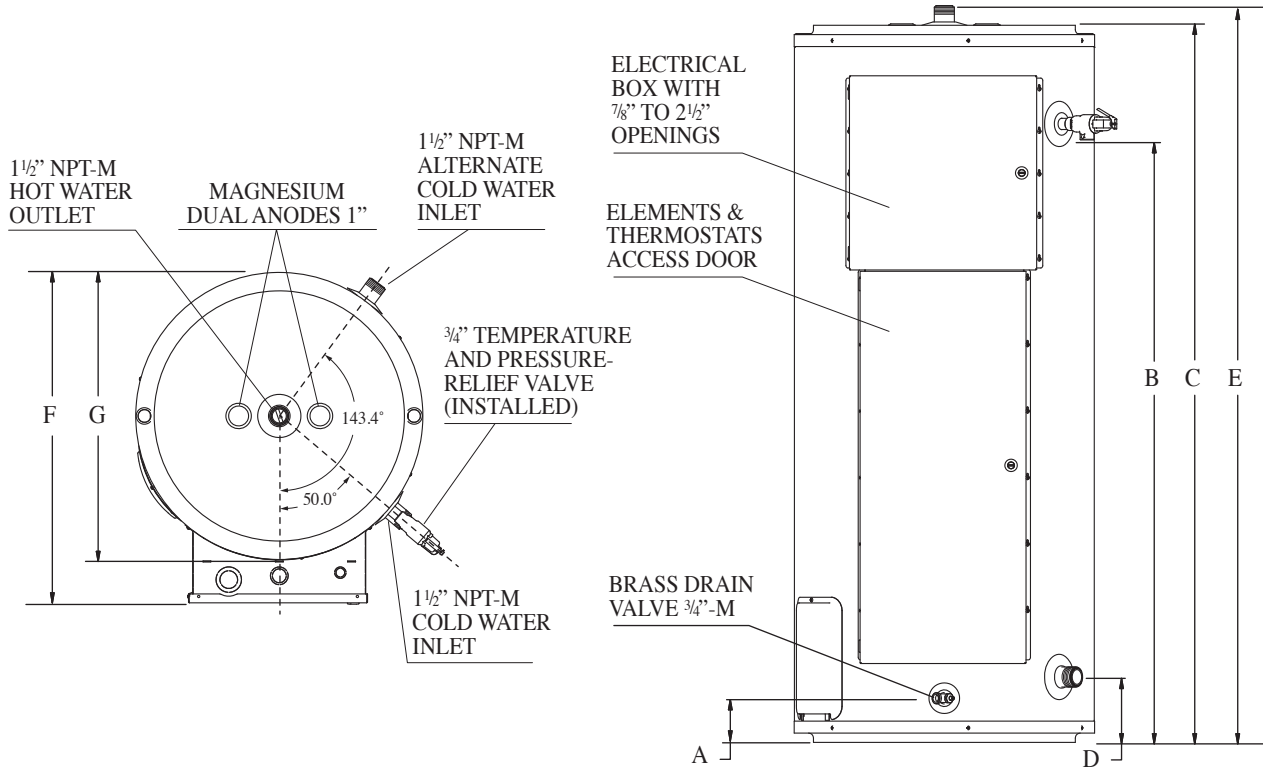

Models	Storage Capacity			A Inches (cm)	B Inches (cm)	C Inches (cm)	D Inches (cm)	E Inches (cm)	F Inches (cm)	G Inches (cm)	Est. Ship. Weight	
	Imp. gal.	Litres	U.S. gal.								lb.	kg
All 112	99	450	119	4 1/8 (10.5)	56 5/8 (143.8)	67 3/8 (171.1)	6 1/8 (15.6)	69 1/4 (175.9)	32 5/8 (82.9)	28 1/4 (71.8)	435	197.3

Notes: \_\_\_\_\_  
 \_\_\_\_\_  
 \_\_\_\_\_

JOB TITLE \_\_\_\_\_

SUBMITTED DATE \_\_\_\_\_

ADDRESS \_\_\_\_\_

REQUIRED PRODUCT \_\_\_\_\_

CONTRACTOR \_\_\_\_\_

MODEL NO. \_\_\_\_\_ SIZE \_\_\_\_\_ QUANTITY \_\_\_\_\_

MODEL NO. \_\_\_\_\_ SIZE \_\_\_\_\_ QUANTITY \_\_\_\_\_

ADDRESS \_\_\_\_\_

MODEL NO. \_\_\_\_\_ SIZE \_\_\_\_\_ QUANTITY \_\_\_\_\_

MODEL NO. \_\_\_\_\_ SIZE \_\_\_\_\_ QUANTITY \_\_\_\_\_

ENGINEER \_\_\_\_\_

REQUIRED DATE \_\_\_\_\_

In accordance with our company policy of on-going product improvement, Giant Factories Inc. reserves the right to make changes without prior notice.

[giantinc.com](http://giantinc.com)



Enhancing everyday living



# ENGINEERING SUBMITTAL DATA SHEET

Commercial electric water heaters, Flexible  
**112 MODELS (Heavy Duty)**

99 imperial gallons / 450 litres

Insulated with 2" Eco-Friendly **GREENFOAM**

**208, 240, 277 & 480 Volts**

These models meet the safety and construction requirements of CSA Standard C22.2 No. 110 and meet or exceed the standby loss requirements of NRCan and ASHRAE 90.1 Standard.

Models*	Input (kW)	Amperage				Phase(s)	Number of elements	
		208 Volts	240 Volts	277 Volts	480 Volts			
<b>Heavy Duty with 3, 6, or 9 elements</b>								
1123Y-1-6S	6	28.8	25.0	21.7	12.5	1	3	
1123Y-3-6S		16.7	14.5	—	7.2	3		
1123Y-1-9S	9	43.3	37.5	32.5	18.8	1		
1123Y-3-9S		25.0	21.7	—	10.8	3		
1123Y-1-12S	12	57.7	50.0	43.3	25.0	1		
1123Y-3-12S		33.3	28.9	—	14.4	3		
1123Y-1-13.5S	13.5	64.9	56.3	48.7	28.1	1		
1123Y-3-13.5S		37.5	32.5	—	16.2	3		
1123Y-1-15S	15	72.1	62.5	54.2	31.3	1		
1123Y-3-15S		41.6	36.1	—	18.0	3		
112XY-1-18S	18	86.5 <sup>†</sup>	75.0	65.0	37.5	1		3 or 6
112XY-3-18S		50.0 <sup>†</sup>	43.3	—	21.7	3		
1126Y-1-24S	24	115.4	100.0	86.6	50.0	1	6	
1126Y-3-24S		66.6	57.7	—	28.9	3		
1126Y-1-27S	27	129.8	112.5	97.5	56.3	1		
1126Y-3-27S		74.9	65.0	—	32.5	3		
1126Y-1-30S	30	144.2	125.0	108.3	62.5	1		
1126Y-3-30S		83.3	72.2	—	36.1	3		
112XY-1-36S	36	173.1 <sup>††</sup>	150.0	130.0	75.0	1	6 or 9	
112XY-3-36S		99.9 <sup>††</sup>	86.6	—	43.3	3		
1129Y-1-40.5S	40.5	194.7	168.8	146.2	84.4	1	9	
1129Y-3-40.5S		112.4	97.4	—	48.7	3		
1129Y-1-45S	45	216.3	187.5	162.5	93.8	1		
1129Y-3-45S		124.9	108.3	—	54.1	3		
1129Y-1-54S	54	—	255.0	194.9	112.5	1		
1129Y-3-54S		—	129.9	—	65.0	3		

\* Replace the "X" in the model number by the element quantity shown in the "Number of elements" column as well as the "Y" by the letter referring to its voltage (refer to the following "Voltage index" as well as the "Model Number Structure" for further details).

† For 208 V Models with a 18 kW input, only the 6-element configuration is possible.

†† For 208 V Models with a 36kW input, only the 9-element configuration is possible.

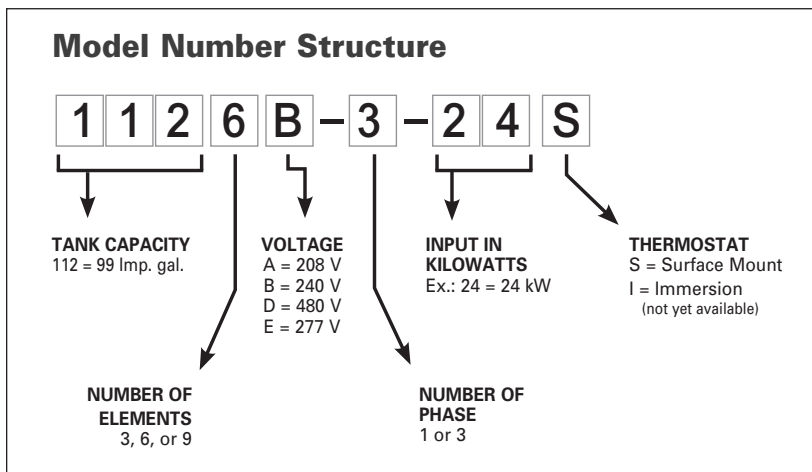

Voltage index	
A	208 Volts
B	240 Volts
D	480 Volts
E	277 Volts

See reverse for this model drawing as well as order details.

In accordance with our company policy of on-going product improvement, Giant Factories Inc. reserves the right to make changes without prior notice.

[giantinc.com](http://giantinc.com)



40 Lesage Avenue, Montréal-East (Québec) Canada H1B 5H3 • Telephone: (514) 645-8893 • Fax: (514) 640-0969

Commercial electric water heaters, Flexible  
**112 MODELS**  
**(Heavy Duty)**  
 99 imperial gallons / 450 litres

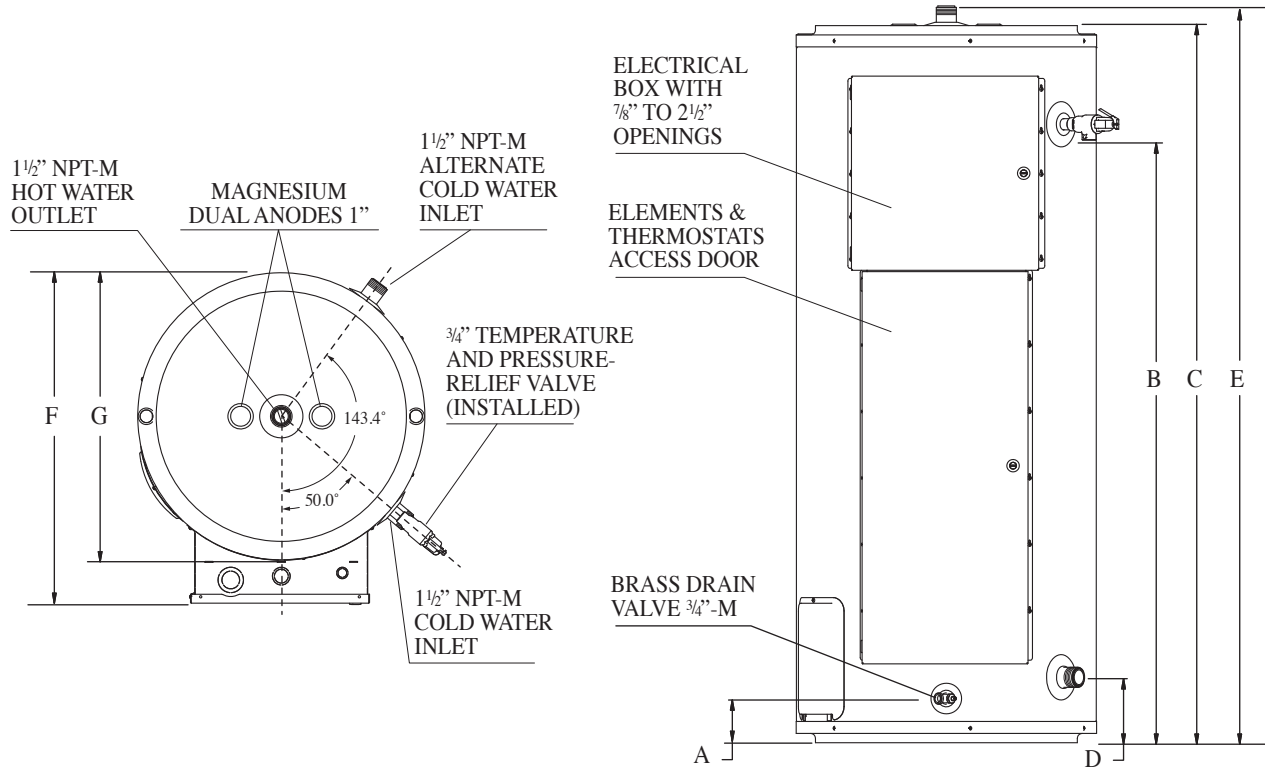

Models	Storage Capacity			A Inches (cm)	B Inches (cm)	C Inches (cm)	D Inches (cm)	E Inches (cm)	F Inches (cm)	G Inches (cm)	Est. Ship. Weight	
	Imp. gal.	Litres	U.S. gal.								lb.	kg
All 112	99	450	119	4 1/8 (10.5)	56 5/8 (143.8)	67 3/8 (171.1)	6 1/8 (15.6)	69 1/4 (175.9)	32 5/8 (82.9)	28 1/4 (71.8)	435	197.3

Notes: \_\_\_\_\_  
 \_\_\_\_\_  
 \_\_\_\_\_

JOB TITLE \_\_\_\_\_

SUBMITTED DATE \_\_\_\_\_

ADDRESS \_\_\_\_\_  
 \_\_\_\_\_

REQUIRED PRODUCT \_\_\_\_\_

CONTRACTOR \_\_\_\_\_

MODEL NO. \_\_\_\_\_ SIZE \_\_\_\_\_ QUANTITY \_\_\_\_\_

MODEL NO. \_\_\_\_\_ SIZE \_\_\_\_\_ QUANTITY \_\_\_\_\_

ADDRESS \_\_\_\_\_  
 \_\_\_\_\_

MODEL NO. \_\_\_\_\_ SIZE \_\_\_\_\_ QUANTITY \_\_\_\_\_

MODEL NO. \_\_\_\_\_ SIZE \_\_\_\_\_ QUANTITY \_\_\_\_\_

ENGINEER \_\_\_\_\_

REQUIRED DATE \_\_\_\_\_

In accordance with our company policy of on-going product improvement, Giant Factories Inc. reserves the right to make changes without prior notice.

[giantinc.com](http://giantinc.com)





Enhancing everyday living



# ENGINEERING SUBMITTAL DATA SHEET

Commercial electric water heaters, Flexible  
**112 MODELS (Heavy Duty)**

99 Imp. gallons / 450 litres

Insulated with 2" Eco-Friendly **GREENFOAM**

**600 Volts / Three phases  
with 3, 6, or 9 elements**

These models meet the safety and construction requirements of CSA Standard C22.2 No. 110 and meet or exceed the standby loss requirements of NRCAN and ASHRAE 90.1 Standard.

Models	Input (kW)	Number of elements	Amperage
1123C-3-6S	6	3	5.8
1123C-3-9S	9		8.7
1123C-3-12S	12		11.5
1123C-3-13.5S	13.5		13.0
1123C-3-15S	15		14.4
1123C-3-18S	18		17.3
1126C-3-18S	18	6	17.3
1126C-3-24S	24		23.1
1126C-3-27S	27		26.0
1126C-3-30S	30		28.9
1126C-3-36S	36		34.6
1129C-3-36S	36		9
1129C-3-40.5S	40.5	39.0	
1129C-3-45S	45	43.3	
1129C-3-54S	54	52.0	
1129C-3-63S	63	60.6	

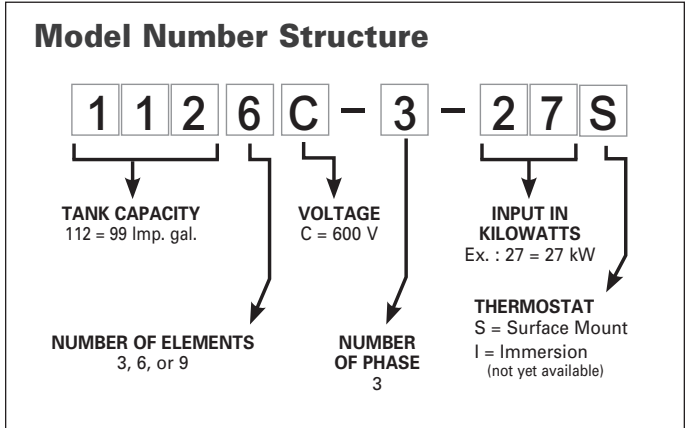

Voltage Index	
C	600 Volts

Notes: \_\_\_\_\_

\_\_\_\_\_

\_\_\_\_\_

\_\_\_\_\_

\_\_\_\_\_

\_\_\_\_\_

\_\_\_\_\_

\_\_\_\_\_

\_\_\_\_\_

\_\_\_\_\_

\_\_\_\_\_

\_\_\_\_\_

\_\_\_\_\_

\_\_\_\_\_

\_\_\_\_\_

\_\_\_\_\_

\_\_\_\_\_

\_\_\_\_\_

\_\_\_\_\_

\_\_\_\_\_

\_\_\_\_\_

\_\_\_\_\_

\_\_\_\_\_

See reverse for this model drawing as well as order details.

In accordance with our company policy of on-going product improvement, Giant Factories Inc. reserves the right to make changes without prior notice.

[giantinc.com](http://giantinc.com)



40 Lesage Avenue, Montréal-East (Québec) Canada H1B 5H3 • Telephone: (514) 645-8893 • Fax: (514) 640-0969



Enhancing everyday living

Commercial electric water heaters, Flexible  
**112 MODELS (Heavy Duty)**

99 Imp. gallons / 450 litres

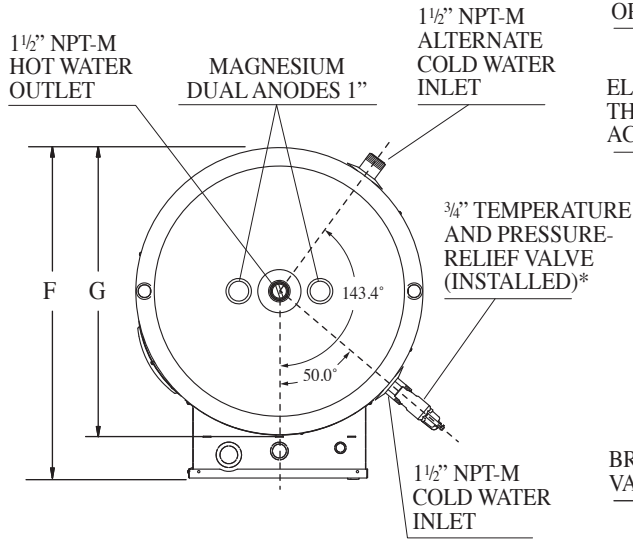

\*Except for model at 63kW, a 1" relief valve and a tee fitting are supplied and need to be installed on the hot water outlet. See Owner's Manual for details.

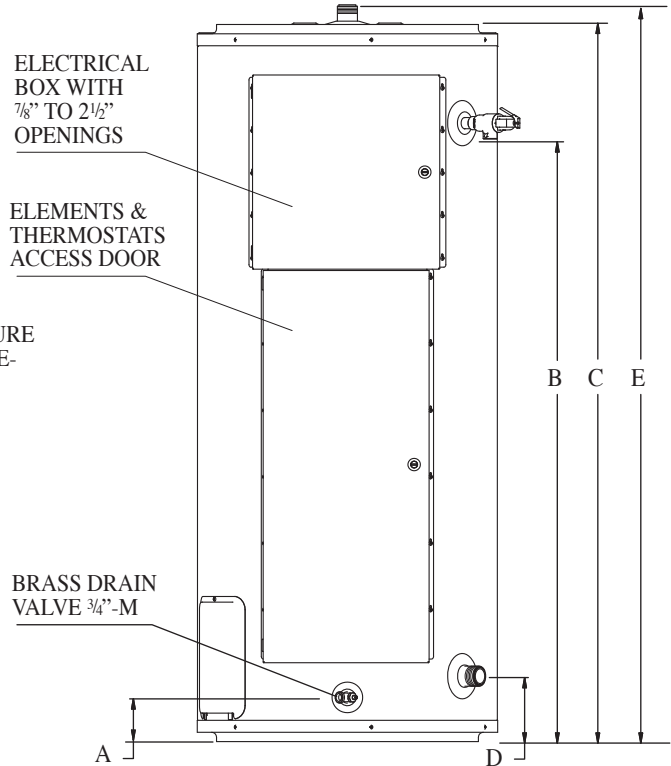

Models	Storage Capacity			A Inches (cm)	B Inches (cm)	C Inches (cm)	D Inches (cm)	E Inches (cm)	F Inches (cm)	G Inches (cm)	Est. Ship. Weight	
	Imp. gal.	Litres	U.S. gal.								lb.	kg
All 112	99	450	119	4 1/8 (10.5)	56 5/8 (143.8)	67 3/8 (171.1)	6 1/8 (15.6)	69 1/4 (175.9)	32 5/8 (82.9)	28 1/4 (71.8)	435	197.3

Notes : \_\_\_\_\_  
 \_\_\_\_\_  
 \_\_\_\_\_

JOB TITLE \_\_\_\_\_

SUBMITTED DATE \_\_\_\_\_

ADDRESS \_\_\_\_\_  
 \_\_\_\_\_

REQUIRED PRODUCT \_\_\_\_\_

CONTRACTOR \_\_\_\_\_

MODEL NO. \_\_\_\_\_ SIZE \_\_\_\_\_ QUANTITY \_\_\_\_\_

ADDRESS \_\_\_\_\_  
 \_\_\_\_\_

MODEL NO. \_\_\_\_\_ SIZE \_\_\_\_\_ QUANTITY \_\_\_\_\_

ENGINEER \_\_\_\_\_

MODEL NO. \_\_\_\_\_ SIZE \_\_\_\_\_ QUANTITY \_\_\_\_\_

MODEL NO. \_\_\_\_\_ SIZE \_\_\_\_\_ QUANTITY \_\_\_\_\_

REQUIRED DATE \_\_\_\_\_

In accordance with our company policy of on-going product improvement, Giant Factories Inc. reserves the right to make changes without prior notice.

[giantinc.com](http://giantinc.com)



40 Lesage Avenue, Montréal-East (Québec) Canada H1B 5H3 • Telephone: (514) 645-8893 • Fax: (514) 640-0969