



Enhancing everyday living



ENGINEERING SUBMITTAL DATA SHEET

Commercial electric water heaters, Flexible

108 MODELS (Light & Medium Duty)

61 imperial gallons / 279 litres

Insulated with 2" Eco-Friendly **GREENFOAM**

208, 240, 277 & 480 Volts / Single phase

These models meet the safety and construction requirements of CSA Standard C22.2 No. 110 and meet or exceed the standby loss requirements of NRCan and ASHRAE 90.1 Standard.

Models*	Input (kW)	Amperage				Phase	Number of elements
		208 Volts	240 Volts	277 Volts	480 Volts		
Light Duty (2 elements) & Medium Duty (4 elements)							
1082Y-1-3S	3	14.4	12.5	10.8	6.3	1	2
1082Y-1-4.5S	4.5	21.6	18.8	16.2	9.4		
1082Y-1-5S	5	24.0	20.8	18.1	10.4		
1082Y-1-6S	6	—	25.0	21.7	12.5		
1084Y-1-6S	6	28.8	25.0	21.7	12.5	1	4
1084Y-1-9S	9	43.3	37.5	32.5	18.8		
1084Y-1-10S	10	48.1	41.7	36.1	20.8		
1084Y-1-12S	12	—	50.0	43.3	25.0		

* Replace the "Y" by the letter referring to its voltage (refer to the following "Voltage index" as well as the "Model Number Structure" for further details).

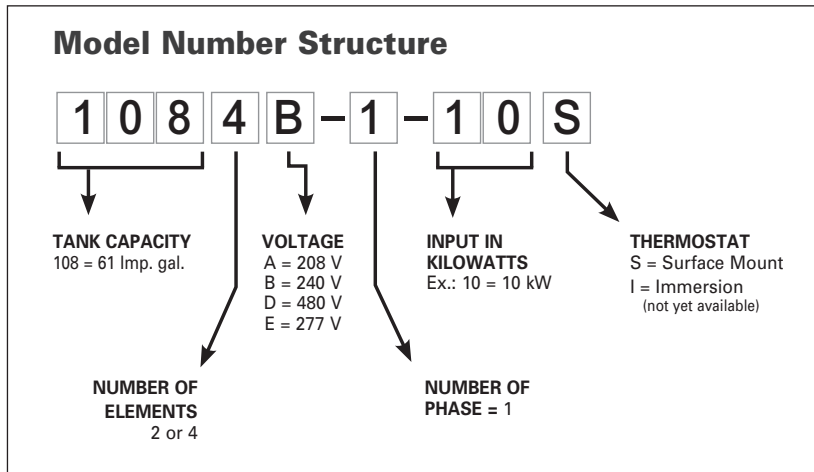

Voltage index	
A	208 Volts
B	240 Volts
D	480 Volts
E	277 Volts

Notes: _____

See reverse for this model drawing as well as order details.



In accordance with our company policy of on-going product improvement, Giant Factories Inc. reserves the right to make changes without prior notice.

giantinc.com



40 Lesage Avenue, Montréal-East (Québec) Canada H1B 5H3 • Telephone: (514) 645-8893 • Fax: (514) 640-0969

Commercial electric water heaters, Flexible
108 MODELS
(Light & Medium Duty)
 61 imperial gallons / 279 litres

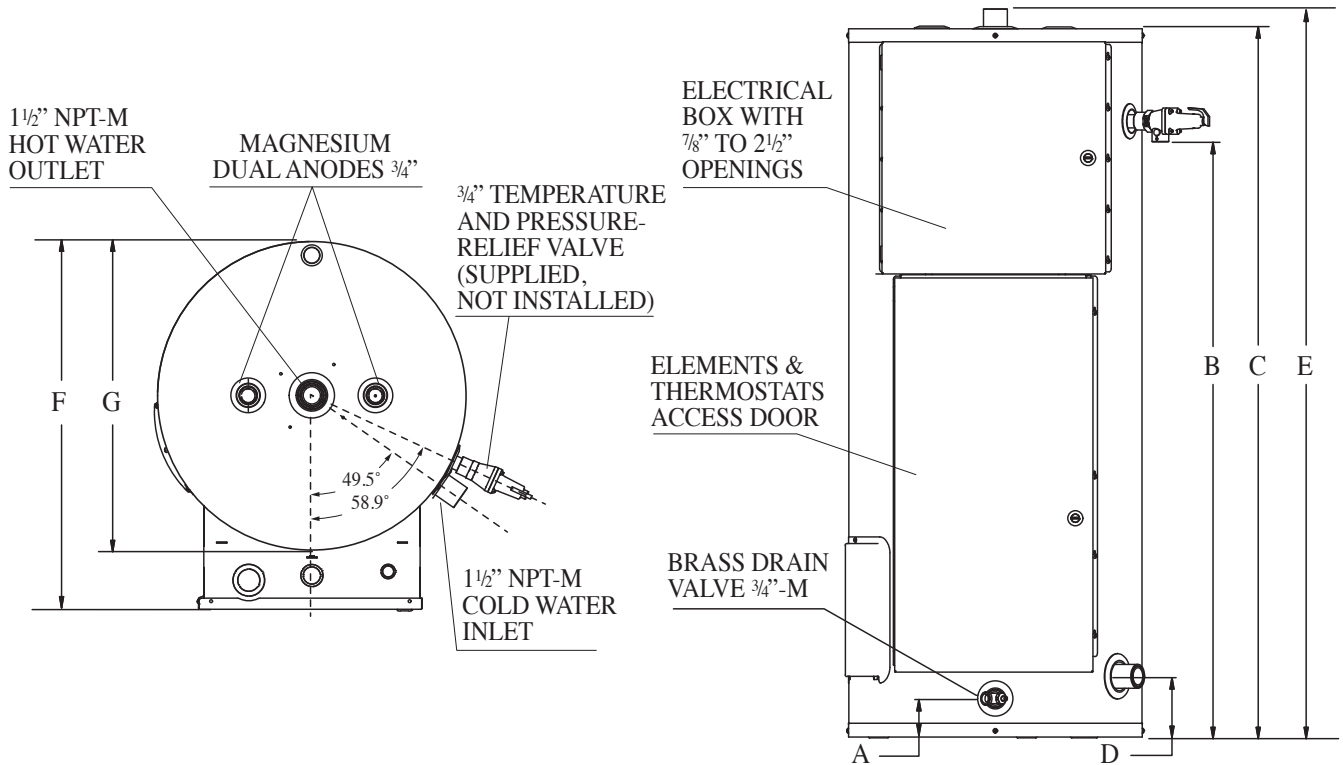

Models	Storage Capacity			A Inches (cm)	B Inches (cm)	C Inches (cm)	D Inches (cm)	E Inches (cm)	F Inches (cm)	G Inches (cm)	Est. Ship. Weight	
	Imp. gal.	Litres	U.S. gal.								lb.	kg
All 108	61	279	74	3 1/8 (7.9)	51 3/8 (130.5)	59 5/8 (151.4)	4 7/8 (12.4)	60 7/8 (154.6)	28 1/4 (71.8)	24 (61)	285	129.3

Notes: _____

JOB TITLE _____

SUBMITTED DATE _____

ADDRESS _____

REQUIRED PRODUCT _____

CONTRACTOR _____

MODEL NO. _____ SIZE _____ QUANTITY _____

MODEL NO. _____ SIZE _____ QUANTITY _____

ADDRESS _____

MODEL NO. _____ SIZE _____ QUANTITY _____

MODEL NO. _____ SIZE _____ QUANTITY _____

ENGINEER _____

REQUIRED DATE _____

In accordance with our company policy of on-going product improvement, Giant Factories Inc. reserves the right to make changes without prior notice.

giantinc.com





Enhancing everyday living



ENGINEERING SUBMITTAL DATA SHEET

Commercial electric water heaters, Flexible
108 MODELS (Heavy Duty)

61 imperial gallons / 279 litres

Insulated with 2" Eco-Friendly **GREENFOAM**

208, 240, 277 & 480 Volts

These models meet the safety and construction requirements of CSA Standard C22.2 No. 110 and meet or exceed the standby loss requirements of NRCan and ASHRAE 90.1 Standard.

Models*	Input (kW)	Amperage				Phase(s)	Number of elements
		208 Volts	240 Volts	277 Volts	480 Volts		
Heavy Duty with 3, 6, or 9 elements							
1083Y-1-6S	6	28.8	25.0	21.7	12.5	1	3
1083Y-3-6S		16.7	14.5	—	7.2	3	
1083Y-1-9S	9	43.3	37.5	32.5	18.8	1	
1083Y-3-9S		25.0	21.7	—	10.8	3	
1083Y-1-12S	12	57.7	50.0	43.3	25.0	1	
1083Y-3-12S		33.3	28.9	—	14.4	3	
1083Y-1-13.5S	13.5	64.9	56.3	48.7	28.1	1	
1083Y-3-13.5S		37.5	32.5	—	16.2	3	
1083Y-1-15S	15	72.1	62.5	54.2	31.3	1	
1083Y-3-15S		41.6	36.1	—	18.0	3	
108XY-1-18S	18	86.5†	75.0	65.0	37.5	1	3 or 6
108XY-3-18S		50.0†	43.3	—	21.7	3	
1086Y-1-24S	24	115.4	100.0	86.6	50.0	1	6
1086Y-3-24S		66.6	57.7	—	28.9	3	
1086Y-1-27S	27	129.8	112.5	97.5	56.3	1	
1086Y-3-27S		74.9	65.0	—	32.5	3	
1086Y-1-30S	30	144.2	125.0	108.3	62.5	1	
1086Y-3-30S		83.3	72.2	—	36.1	3	
108XY-1-36S	36	173.1††	150.0	130.0	75.0	1	6 or 9
108XY-3-36S		99.9††	86.6	—	43.3	3	
1089Y-1-40.5S	40.5	194.7	168.8	146.2	84.4	1	9
1089Y-3-40.5S		112.4	97.4	—	48.7	3	
1089Y-1-45S	45	216.3	187.5	162.5	93.8	1	
1089Y-3-45S		124.9	108.3	—	54.1	3	
1089Y-1-54S	54	—	255.0	194.9	112.5	1	
1089Y-3-54S		—	129.9	—	65.0	3	

* Replace the "X" in the model number by the element quantity shown in the "Number of elements" column as well as the "Y" by the letter referring to its voltage (refer to the following "Voltage index" as well as the "Model Number Structure" for further details).

† For 208 V Models with a 18 kW input, only the 6-element configuration is possible.

†† For 208 V Models with a 36kW input, only the 9-element configuration is possible.

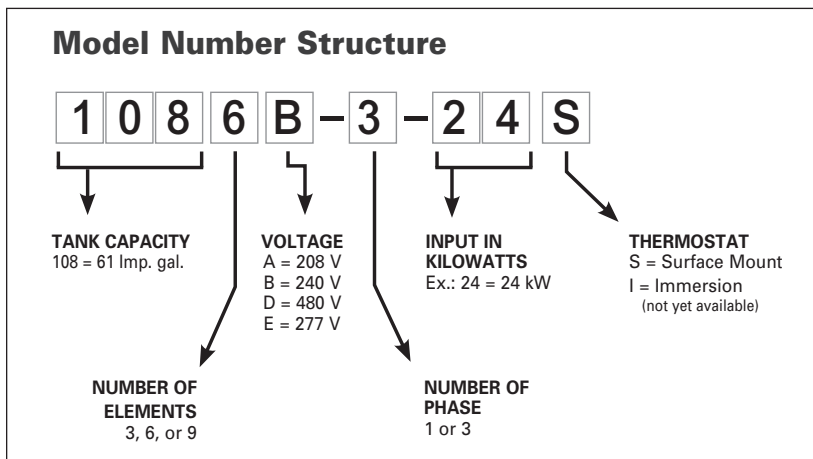

Voltage index	
A	208 Volts
B	240 Volts
D	480 Volts
E	277 Volts

See reverse for this model drawing as well as order details.

In accordance with our company policy of on-going product improvement, Giant Factories Inc. reserves the right to make changes without prior notice.

giantinc.com



40 Lesage Avenue, Montréal-East (Québec) Canada H1B 5H3 • Telephone: (514) 645-8893 • Fax: (514) 640-0969

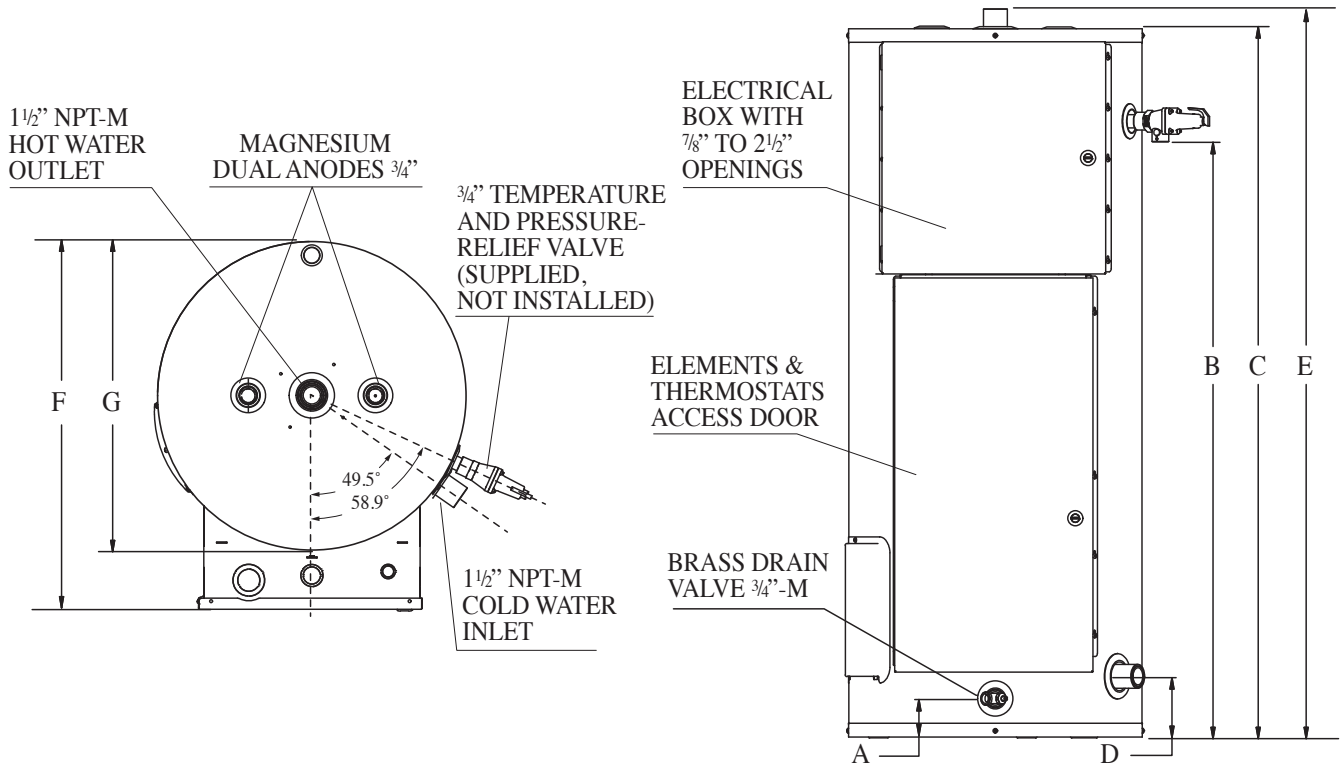

Models	Storage Capacity			A Inches (cm)	B Inches (cm)	C Inches (cm)	D Inches (cm)	E Inches (cm)	F Inches (cm)	G Inches (cm)	Est. Ship. Weight	
	Imp. gal.	Litres	U.S. gal.								lb.	kg
All 108	61	279	74	3 1/8 (7.9)	51 3/8 (130.5)	59 5/8 (151.4)	4 7/8 (12.4)	60 7/8 (154.6)	28 1/4 (71.8)	24 (61)	285	129.3

Notes: _____

JOB TITLE _____

SUBMITTED DATE _____

ADDRESS _____

REQUIRED PRODUCT _____

CONTRACTOR _____

MODEL NO. _____ SIZE _____ QUANTITY _____

ADDRESS _____

MODEL NO. _____ SIZE _____ QUANTITY _____

ENGINEER _____

MODEL NO. _____ SIZE _____ QUANTITY _____

MODEL NO. _____ SIZE _____ QUANTITY _____

REQUIRED DATE _____

In accordance with our company policy of on-going product improvement, Giant Factories Inc. reserves the right to make changes without prior notice.

giantinc.com



Enhancing everyday living



ENGINEERING SUBMITTAL DATA SHEET

Commercial electric water heaters, Flexible
108 MODELS (Heavy Duty)

61 Imp. gallons / 279 litres

Insulated with 2" Eco-Friendly **GREENFOAM™**

600 Volts / Three phases
with 3, 6 or 9 elements

These models meet the safety and construction requirements of CSA Standard C22.2 No. 110 and meet or exceed the standby loss requirements of NRCAN and ASHRAE 90.1 Standard.

Models	Input (kW)	Number of elements	Amperage
1083C-3-6S	6	3	5.8
1083C-3-9S	9		8.7
1083C-3-12S	12		11.5
1083C-3-13.5S	13.5		13.0
1083C-3-15S	15		14.4
1083C-3-18S	18		17.3
1086C-3-18S	18	6	17.3
1086C-3-24S	24		23.1
1086C-3-27S	27		26.0
1086C-3-30S	30		28.9
1086C-3-36S	36		34.6
1089C-3-36S	36		9
1089C-3-40.5S	40.5	39.0	
1089C-3-45S	45	43.3	
1089C-3-54S	54	52.0	

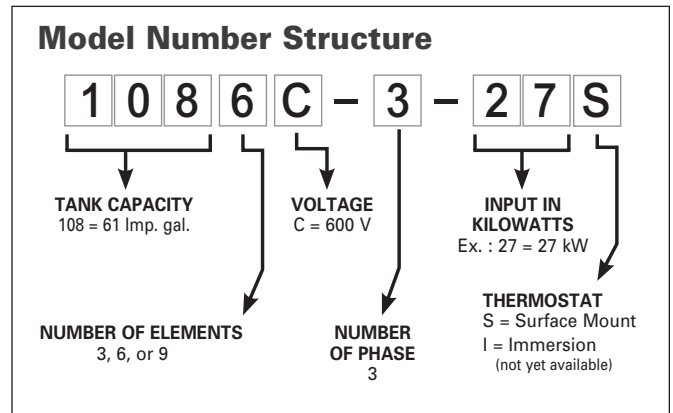

Voltage Index	
C	600 Volts

Notes : _____

See reverse for this model drawing as well as order details.

In accordance with our company policy of on-going product improvement, Giant Factories Inc. reserves the right to make changes without prior notice.

giantinc.com



40 Lesage Avenue, Montréal-East (Québec) Canada H1B 5H3 • Telephone: (514) 645-8893 • Fax: (514) 640-0969

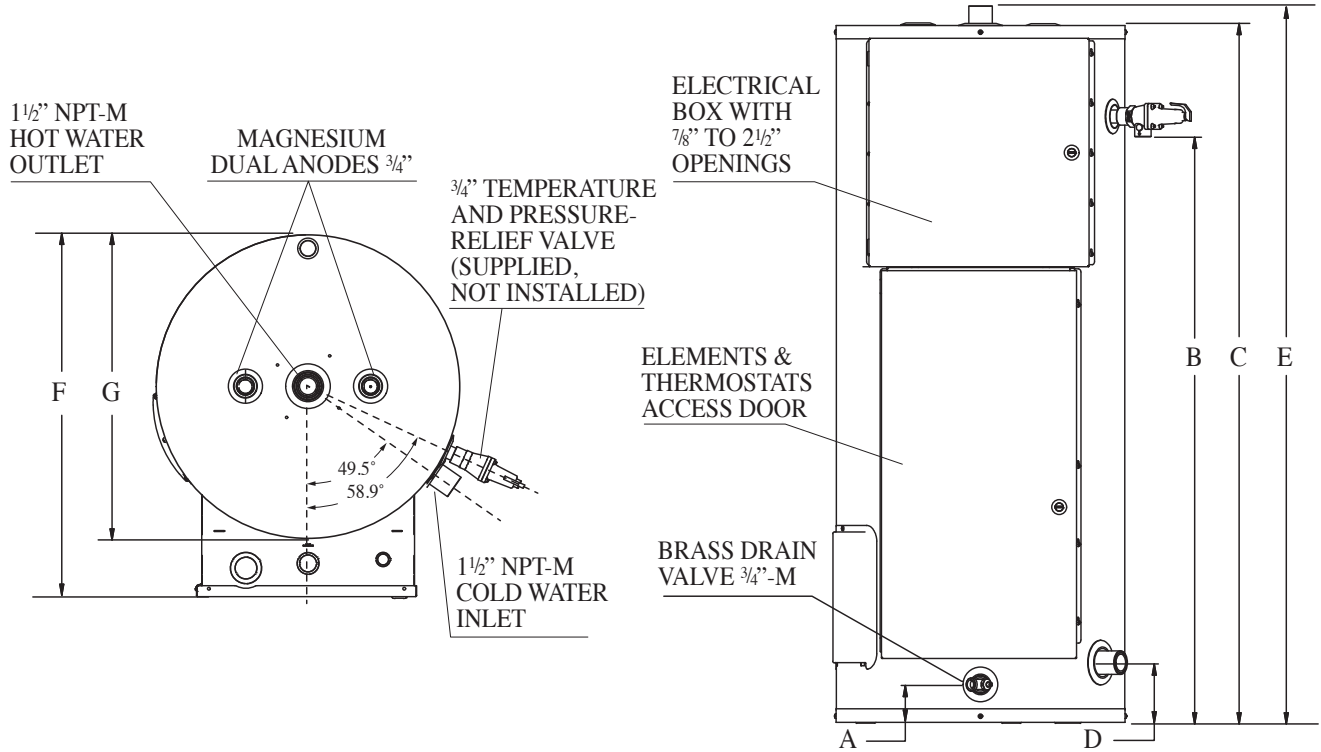

Models	Storage Capacity			A Inches (cm)	B Inches (cm)	C Inches (cm)	D Inches (cm)	E Inches (cm)	F Inches (cm)	G Inches (cm)	Est. Ship. Weight	
	Imp. gal.	Litres	U.S. gal.								lb.	kg
All 108	61	279	74	3 1/8 (7.9)	51 3/8 (130.5)	59 5/8 (151.4)	4 7/8 (12.4)	60 7/8 (154.6)	28 1/4 (71.8)	24 (61)	285	129.3

Notes : _____

JOB TITLE _____

SUBMITTED DATE _____

ADDRESS _____

REQUIRED PRODUCT _____

CONTRACTOR _____

MODEL NO. _____ SIZE _____ QUANTITY _____

MODEL NO. _____ SIZE _____ QUANTITY _____

ADDRESS _____

MODEL NO. _____ SIZE _____ QUANTITY _____

MODEL NO. _____ SIZE _____ QUANTITY _____

ENGINEER _____

REQUIRED DATE _____

In accordance with our company policy of on-going product improvement, Giant Factories Inc. reserves the right to make changes without prior notice.

giantinc.com