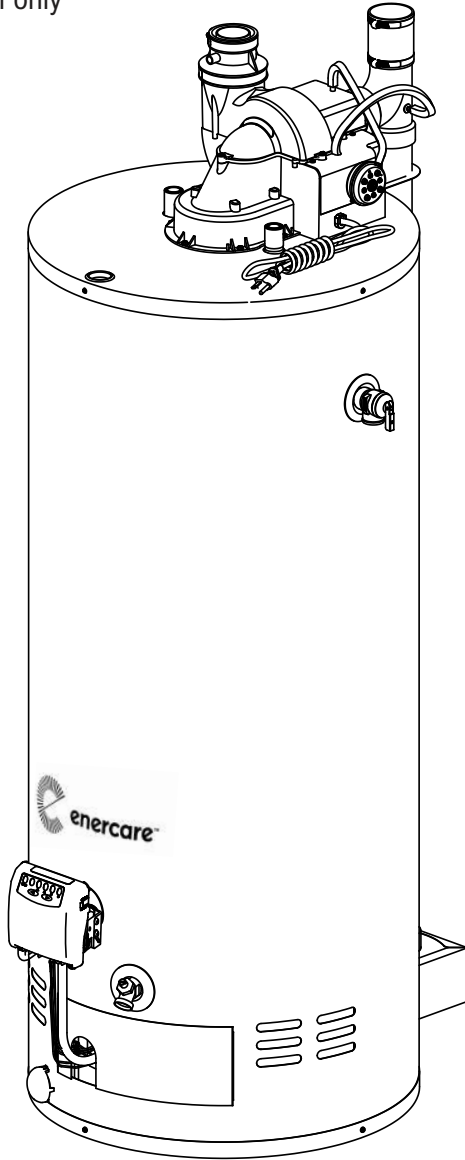


# RESIDENTIAL POWER DIRECT VENT GAS-FIRED WATER HEATERS (EQUIPPED WITH FVIR TECHNOLOGY)

## OWNER'S MANUAL

### INSTALLATION AND OPERATING INSTRUCTIONS

PDV 2" Model only  
with Emerson  
generation II  
gas control  
valve



#### ⚠ WARNING

This water heater **IS NOT** design certified for installation in a mobile home or for installation outdoors.

#### ⚠ WARNING

If the information in these instructions is not followed exactly, a fire or explosion may result causing property damage, personal injury, or death.

**DO NOT** store or use gasoline or other flammable vapours and liquids in the vicinity of this or any other appliance.

#### WHAT TO DO IF YOU SMELL GAS

- **DO NOT** try to light any appliance.
- **DO NOT** touch any electrical switch.
- **DO NOT** use any phone in your building.
- **From a neighbour's phone, immediately call your gas supplier and Enercare Home Services.** Follow their instructions.
- If you cannot reach immediately the above suppliers, call the fire department at 911.

Installation and service must be performed only by Enercare Home Services at 1-800-266-3939.

### IMPORTANT

READ THESE INSTRUCTIONS CAREFULLY BEFORE BEGINNING THE INSTALLATION. PROPER INSTALLATION WILL PROVIDE SAFE & EFFICIENT SERVICE, AND AVOID NEEDLESS EXPENSES NOT COVERED BY THE WARRANTY. SHOULD YOU HAVE ANY QUESTIONS, PLEASE CONTACT ENERCARE HOME SERVICES AT 1-800-266-3939.

**SAVE THIS MANUAL FOR FUTURE REFERENCES.**

For your records, write the model and serial number here:

**Model #** \_\_\_\_\_


**Serial #** \_\_\_\_\_



C US  
LOW LEAD  
CONTENT

# TABLE OF CONTENTS

<b>Safety Information</b> . . . . .	<b>3</b>	Installation Checklist . . . . .	15
<b>Installation Instructions</b> . . . . .	<b>4</b>	<b>Operating Instructions</b> . . . . .	<b>16</b>
Location . . . . .	4	Lighting the Water Heater . . . . .	16
Minimum Clearances . . . . .	4	Lighting instructions . . . . .	16
Venting . . . . .	4	Water Temperature Regulation . . . . .	17
Venting Connection to the water heater . . . . .	5	Out of Fuel . . . . .	18
Through-the-Wall Venting Installation . . . . .	8	<b>General Maintenance</b> . . . . .	<b>18</b>
Concentric Vent Termination Kit Installation . . . . .	8	Housekeeping . . . . .	18
Through-the-Roof Venting Installation . . . . .	8	Flammable Vapour Sensor . . . . .	18
Pipe Assembly . . . . .	10	Condensation . . . . .	18
Vent Termination Through-The-Wall . . . . .	10	Burner Ignitor Assembly . . . . .	18
Vent Termination Through-The-Roof . . . . .	10	Water Heater Tank . . . . .	18
Restrictor Screens . . . . .	11	Temperature and Pressure-Relief Valve . . . . .	18
Condensation in the Venting System . . . . .	11	Venting System Inspection . . . . .	19
Water Piping . . . . .	12	Anode . . . . .	19
Temperature and Pressure-Relief Valve . . . . .	12	Draining the Water Heater . . . . .	19
Pressure Build-up in a Water System . . . . .	12	Vacation . . . . .	19
Filling the Water Heater . . . . .	12	Getting Service for your Water Heater . . . . .	19
Gas Connections . . . . .	13	<b>Troubleshooting Guide</b> . . . . .	<b>20</b>
Wiring . . . . .	13		
Installation Instructions for Water Heaters Approved for Combination Space Heating and Potable Water Heating . . . . .	14		


WARNING

**Flammable Vapour Sensor**

Do not remove the protective cover. Do not spray water or leak detector products on this sensor. Do not expose this sensor to bleach or other liquid cleaning products. Avoid humid environments and freezing temperatures.

If the sensor detects the presence of flammable vapours, the gas control will switch to lock-out mode and the water heater will shut down. Do not try and restart the water heater. Have the water heater inspected immediately by a qualified service technician of Enercare Home Services at 1-800-266-3939.

If flammable vapours are detected:

- **DO NOT** try to light any appliance.
- **DO NOT** touch any electrical switch.
- **DO NOT** use any phone in your building.
- **From a neighbour's phone, immediately call your gas supplier and Enercare Home Services.**  
Follow their instructions.
- If you cannot reach these suppliers, call the fire department at 911.

Immediately contact Enercare Home Services at 1-800-266-3939. **Replacement of a FVIR technology equipped water heater due to a flammable vapour shutdown is not covered under the Enercare rental program and service agreement. Expenses will be paid by the homeowner.**

# SAFETY INFORMATION

Your safety and the safety of others is extremely important during the installation, operation, and servicing of this water heater. Many safety-related messages have been provided in this manual and on your water heater. Always read and abide by all safety messages. These messages will point out the potential hazard, tell you how to reduce the risk of injury, and tell you what will happen if the instructions are not followed.



This is the safety alert symbol. This symbol alerts you to potential hazards that can kill or hurt you and others. All safety messages will follow the safety alert symbol and either the word “**DANGER**” or “**WARNING**”.

## **DANGER**

Serious injury or death can occur if you do not follow the instructions immediately.

## **WARNING**


Serious injury or death can occur if you do not follow the instructions.

## **WARNING**



### **FIRE AND EXPLOSION HAZARD**

Can result in serious injury or death

 Do not store or use gasoline or other flammable vapours and liquids in the vicinity of this or any other appliance. Storage or use of gasoline or other flammable vapours or liquids in the vicinity of this or any other appliance can result in serious injury or death.

## **WARNING**

**DO NOT** use this water heater if any part has been under water. Immediately call Enercare Home Services at 1-800-266-3939 to inspect the water heater. Enercare will have the final decision as to how to handle the situation.

# INSTALLATION INSTRUCTIONS

## IMPORTANT

These instructions have been written as a guide for the proper installation and operation of your water heater, and the manufacturer of this water heater will not accept any liability where these instructions have not been followed. However, for your safety and to avoid damage caused by improper installation, this water heater must be installed by an Enercare Certified Licensed Professional, and meet all local codes or, in the absence of local codes, the latest edition of CAN/CSA B149.1, Natural Gas and Propane Gas Installation Code, in Canada, and/or the latest edition of the National Fuel Gas Code, ANSI Z223.1/NFPA 54, in the United States.

### Before proceeding with the installation instructions:

- 1) Inspect the water heater and its component parts for possible damage. **DO NOT** install or attempt to repair any damaged component parts. If you detect any damage, contact Enercare Home Services at 1-800-266-3939.
- 2) Verify that the type of gas being supplied corresponds to that which is marked on the rating plate and gas control valve of the water heater.

### Location

This water heater should be located close enough to the outside wall so that it is within the venting requirements listed in these installation instructions and as close as possible to the main use of hot water. This location must not be subject to freezing temperatures. The water heater should be positioned, so that there is easy access to the burner, gas control valve, and drain valve. It must be located close to a suitable free-flowing floor drain. Where a floor drain is not adjacent to the water heater, a suitable drain pan must be installed under the water heater (**see Figure 8**). This drain pan should be at least four (4) inches (10.2 cm) larger than the diameter of the water heater, and at least one (1) inch (2.5 cm) deep, providing access to the drain valve. This pan must be piped to a suitable drain to prevent damage to property in the event of a water leak from the piping, the relief valve, or the water heater.

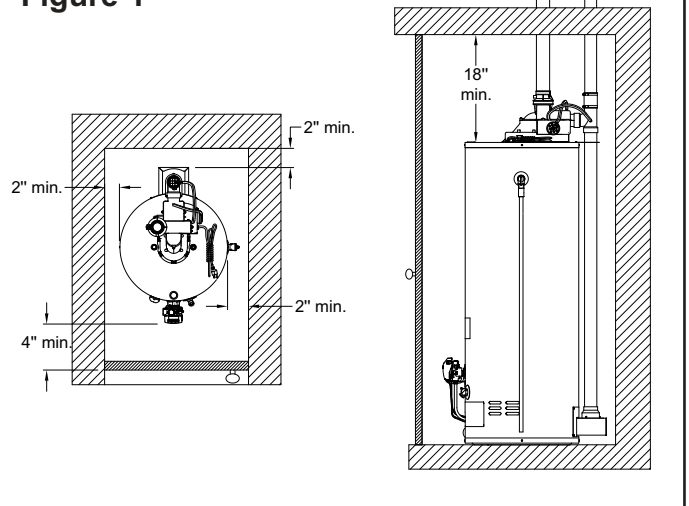
**Sooner or later, all water heaters leak. The manufacturer, based on national building codes, has given the necessary instructions to prevent damage to the building. Under no circumstances is the manufacturer to be held liable for any water damage, in connection with this water heater.**

This water heater is approved for installation on either a combustible or non-combustible floor. However, should this water heater be installed directly on carpeting, the carpeting must be protected by a wood or metal panel beneath the water heater. This panel must extend at least three (3) inches (7.6 cm) beyond the width and depth of the water heater. Should the water heater be installed in an alcove or closet, the entire floor area must be covered by the panel.

### Minimum Clearances

The minimum clearances from combustible material for this water heater are: Two (2) inches (5.1 cm) from the sides and rear, four (4) inches (10.2 cm) from the front, and eighteen (18) inches (45.7 cm) from the top (**see Figure 1**).

Figure 1



### Venting

## ⚠ DANGER

When installing the venting system, make sure to follow all local codes or, in the absence of local codes, CAN/CSA B149.1, Natural Gas and Propane Gas Installation Code, in Canada and/or the National Fuel Gas Code, ANSI Z223.1/NFPA 54, in the United States. **NEVER** operate the water heater unless it is properly ventilated to the outdoors and has adequate air supply for proper operation. Failure to properly install the venting system could result in property damage, personal injury, or death.

This water heater is a power direct vent gas water heater that draws all of its combustion air from outside of the building and vents all of its combustion gases directly outside of the building.

# INSTALLATION INSTRUCTIONS

## IMPORTANT

According to the CAN/CSA-B149, Natural Gas and Propane Installation Code, plastic vent systems installed in Canada must be certified to the STANDARD FOR TYPE BH GAS VENTING SYSTEMS, ULC S636. Components of the certified vent system must not be interchanged with other vent systems or unlisted pipe/fittings. Plastic components and specified primers and glues of the certified vent system must be from a single vent system manufacturer and not inter-mixed with other vent system manufacturer's vent system parts unless those are certified to be used with this system. Plastic vent systems shall also be installed such that the first three (3) feet (91 cm) of pipe from the water heater outlet are readily accessible for visual inspection. The air intake system does not have to meet the requirement of ULC S636, so regular schedule 40 PVC or CPVC pipes and fittings can be used to convey the flow of fresh air to the water heater.

This water can be vented using only one of the following options:

- Two (2) inch (5.1 cm) or three (3) inch (7.6 cm) schedule 40 PVC or CPVC pipe and fittings; **PVC** **CPVC**
- Two (2) inch (5.1 cm) or three (3) inch (7.6 cm) polypropylene rigid pipe and fittings from Centrotherm (Innoflue single wall vent system); **InnoFlue®** **Centrotherm**
- Two (2) inch (5.1 cm) or three (3) inch (7.6 cm) polypropylene rigid pipe and fittings from DuraVent (Polypro single wall gas vent system). **PolyPro®** **DuraVent**

Before installing the vent piping, make sure that the vent system layout has been properly planned. Make sure that the flue baffle has been installed in the flue tube. If the baffle is not present, immediately contact the dealer where the water heater was purchased. **NEVER** operate the water heater without the flue baffle installed. Verify that the location of the water heater respects all clearances from combustible material, all venting requirements (see **Table 1**), and that the vent terminations will be installed as specified by all local codes or, in the absence of local codes, the latest edition of CAN/CSA B149.1, Natural Gas and Propane Installation Code, in Canada, and/or the latest edition of the National Fuel Gas Code, ANSI Z223.1/NFPA 54, in the United States (see **Figure 4**).

**Table 1**

MAXIMUM EQUIVALENT LENGTH FOR VENT PIPE — DO NOT EXCEED		
VENT PIPE DIAMETER FOR 2" PDV MODELS ONLY	2 inches (5.1 cm)	3 inches (7.6 cm)
Maximum equivalent length*	50.0 feet (15.2 m)	80.0 feet (24.4 m)
Minimum equivalent length*	7.5 feet (2.3 m)	9.5 feet (2.9 m)
One 45° elbow is equivalent, in straight pipe, to	3.0 feet (0.9 m)	4.0 feet (1.2 m)
One 90° elbow is equivalent, in straight pipe, to	5.0 feet (1.5 m)	7.0 feet (2.1 m)
Concentric Vent Termination max. length (optional)	40.0 feet (12.2 m)	80.0 feet (24.4 m)
Restrictor Screen	0 to 30 feet (9.1 m)	0 to 80 feet (24.4 m)
Restrictor Screen (for concentric vent termination)	0 to 25 feet (7.6 m)	0 to 80 feet (24.4 m)

\*Note: Outdoor termination elbow not to be counted when determining total length.

This water heater must be vented directly to the outdoors, either horizontally through the wall or vertically through the roof. The venting must not be attached to an existing chimney, or in common with any other appliance, and must not be insulated. If possible, locate the water heater so that the venting length and number of elbows are kept to the minimum necessary to reach the outside.

### Venting Connection to the water heater

PVC PIPE: **PVC**

A vent system adaptor should be installed when using PVC pipes for venting this water heater (see **Figure 2**). The vent system adaptor supplied with the water heater is made of IPEX parts. If another manufacturer of pipe is used to build the vent system, the vent system adaptor must be made from parts of that same manufacturer.

CPVC PIPE: **CPVC**

The CPVC pipe must be inserted directly into the rubber transition fitting on the outlet of the blower assembly.

### POLYPROPYLENE PIPE FROM CENTROTHERM

(Innoflue single wall vent system): **InnoFlue®** **Centrotherm**

Use special appliance adapter from Centrotherm and insert into the rubber transition fitting on the outlet of the blower assembly. Refer to the **Table 2** and **Figure 5** below for proper part number from Centrotherm. On the three (3) inch (7.6 cm) vent pipe, an increaser is necessary.

**Table 2 — Centrotherm™**

	Appliance adapter	Increaser
2-inch (5.1 cm) pipe	ISAA0202	N/A
3-inch (7.6 cm) pipe	ISAA0202	ISIA0203

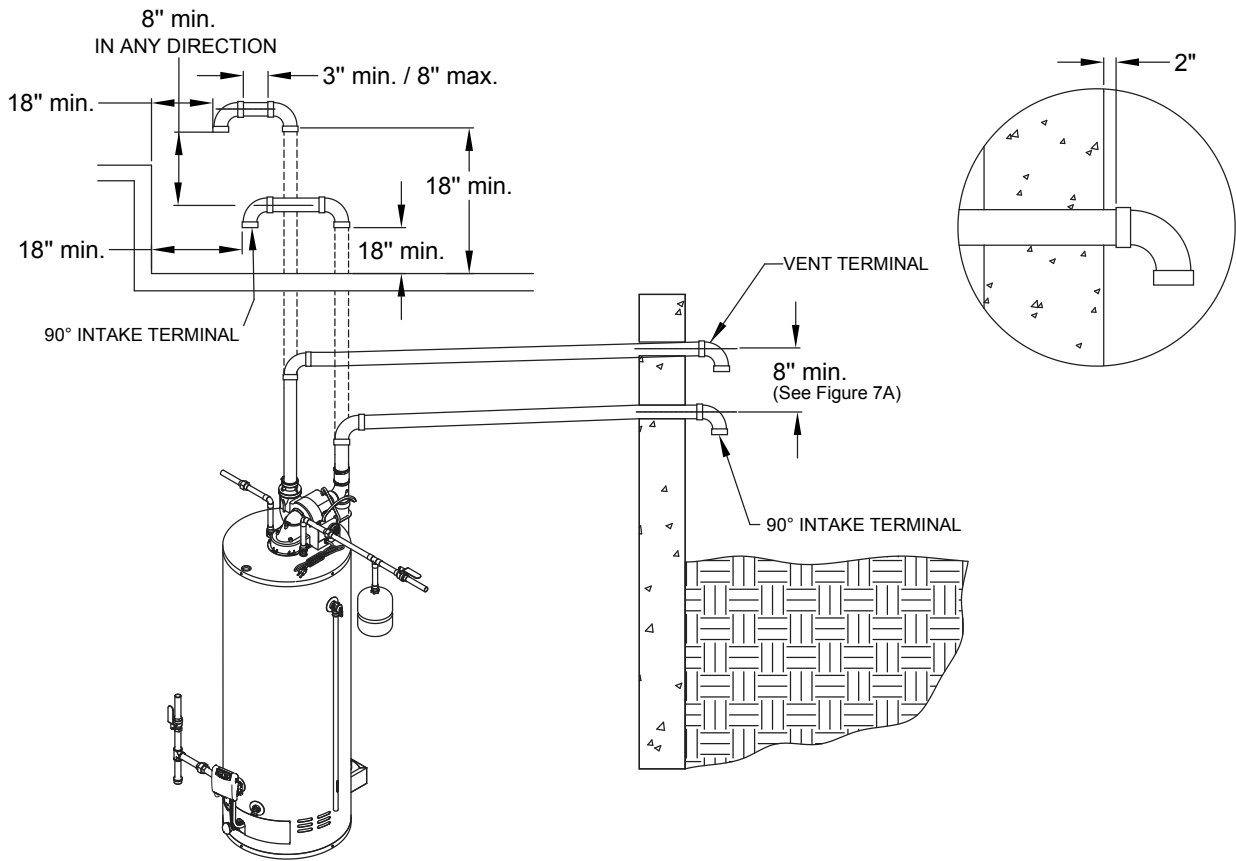
### POLYPROPYLENE PIPE FROM DURAVENT

(Polypro single wall gas vent system): **PolyPro®** **DuraVent**

Use special appliance adapter from DuraVent and insert into the vent system adaptor on the outlet of the blower assembly. Refer to the **Table 3** and **Figure 6** below for proper part number from DuraVent. On the three (3) inch (7.6 cm) vent pipe, an increaser is necessary. Make sure to use the Appliance Adapter clamp to connect the PolyPro Appliance Adaptor to the Vent System Adaptor and to tighten both hose clamps on the Appliance Adapter Clamp to ensure the connection is secure.

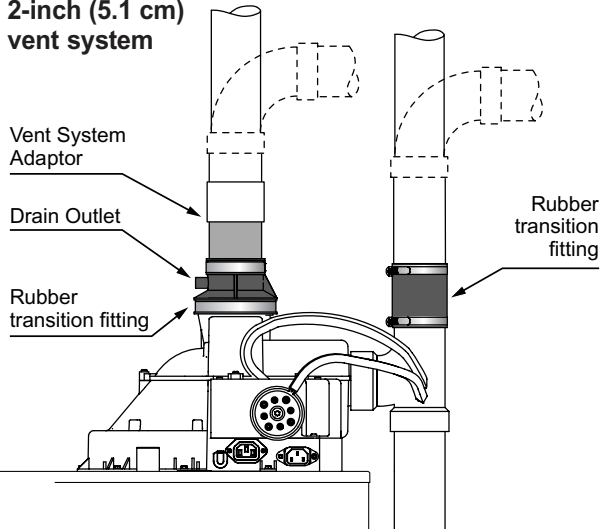
# INSTALLATION INSTRUCTIONS

**Figure 2**

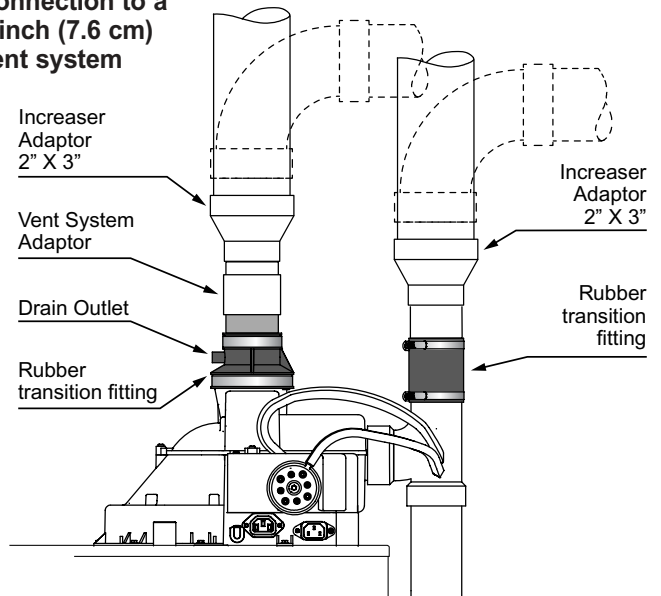


**Figure 3**

**Connection to a 2-inch (5.1 cm) vent system**



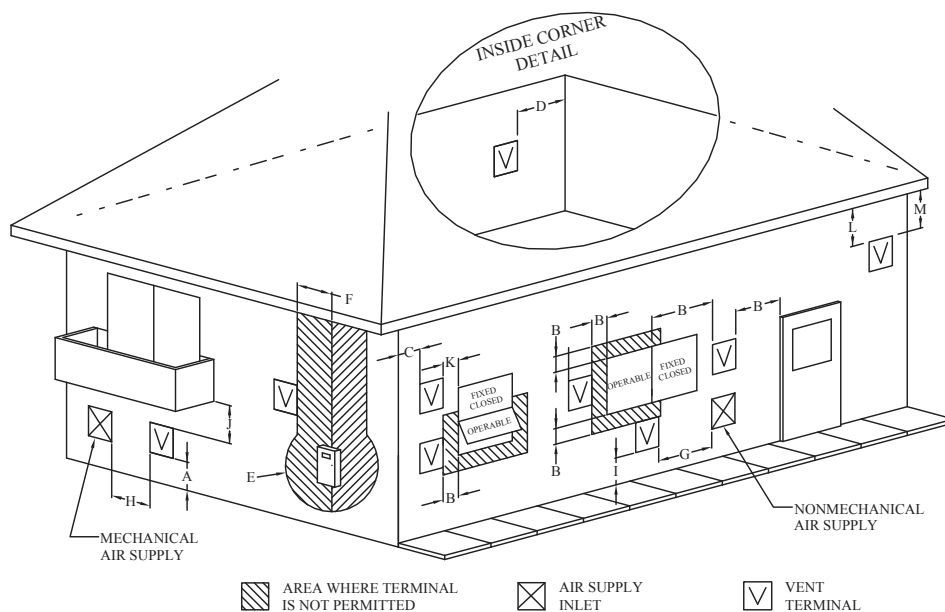
**Connection to a 3-inch (7.6 cm) vent system**



The blower assembly must always have the two (2) inch (5.1 cm) rubber transition fitting. An increasing coupling 2" X 3" is necessary for a three (3) inch (7.6 cm) venting system. This coupling must be installed as close as possible after the rubber transition fitting and in every case, before the first elbow.

# INSTALLATION INSTRUCTIONS

**Figure 4**



**The Vent Termination must have a:**

	<b>Canadian Installations</b>	<b>U.S. Installations</b>
<b>A)</b> Clearance above grade, veranda, porch, deck, or balcony.	12 inches (30 cm)	12 inches (30 cm)
<b>B)</b> Clearance to window or door that may be opened.	12 inches (30 cm)	9 inches (23 cm) or 12 inches (30 cm) * * *
<b>C)</b> Clearance to outside corner.	*	*
<b>D)</b> Clearance to inside corner.	*	3 feet (91 cm)
<b>E)</b> Clearance to service regulator vent outlet.	3 feet (91 cm)	3 feet (91 cm)
<b>F)</b> Clearance to each side of center line extended above meter/regulator assembly.	3 feet (91 cm) within a height of 15 feet (4.57 m) above the meter/regulator assembly	3 feet (91 cm) within a height of 15 feet (4.57 m) above the meter/regulator assembly
<b>G)</b> Clearance to non-mechanical air supply inlet to building or the combustion air inlet to any other appliance.	12 inches (30 cm)	9 inches (23 cm) or 12 inches (30 cm) * * *
<b>H)</b> Clearance to a mechanical air supply inlet.	6 feet (1.82 m)	* * * *
<b>I)</b> Clearance above paved sidewalk or paved driveway located on public property.	7 feet (2.13 m)	7 feet (2.13 m)
<b>J)</b> Clearance under veranda, porch, deck, or balcony.	12 inches (30 cm)**	12 inches (30 cm)**
<b>K)</b> Clearance to permanently closed window.	*	*
<b>L)</b> Vertical clearance to ventilated soffit located above the terminal within a horizontal distance of two (2) feet (61 cm) from the centerline of the terminal.	*	*
<b>M)</b> Clearance to unventilated soffit.	*	*

\* Clearance in accordance with local installation codes and the requirements of the gas supplier.

For Canadian and US installations, the vent shall not terminate above a paved driveway that is located between two (2) single family dwellings and serves both dwellings.

\*\* The veranda, porch, or deck is fully open on a minimum of two (2) sides beneath the floor.

\*\*\* Nine (9) inches (23 cm) for appliances with 10,000 to 50,000 Btu/hr inputs and twelve (12) inches (30 cm) for appliances greater than 50,000 Btu/hr.

\*\*\*\* The vent terminal must terminate at least three (3) feet (91 cm) above any forced air inlet duct located within ten (10) feet (3.05 m).

# INSTALLATION INSTRUCTIONS

**Table 3 — DuraVent™**

	Appliance adaptor	Increaser	Appliance adaptor clamp
2-inch (5.1 cm) pipe	2PPS-AD	N/A	PPS-PAC
3-inch (7.6 cm) pipe	2PPS-AD	2PPS-X3	PPS-PAC

## Through-the-Wall Venting Installation

### ⚠ WARNING

When installing the vent piping make sure that the vent terminal is **NEVER** installed below the air intake terminal. The air intake terminal must always face downward. Failure to follow this instruction could result in property damage, personal injury, or death.

Two (2) vent terminal options are available to vent this water heater. The first is a standard 90-degree elbow facing downward (**see Figure 7a**) and the second is the concentric vent termination kit (**see Figure 7b**).

Cut or drill two (2) holes through the exterior wall, slightly larger than the diameter of the vent pipe selected. The larger holes will allow for final alignment with the water heater. Extend a section of pipe through each hole to the outside and attach the terminating elbow to the exterior end of each pipe. The vent and air intake terminals must be at least eight (8) inches (20.3 cm) apart and the vent terminal must **NEVER** be installed below the air intake terminal for any reason (**see Figure 7a**). The air intake terminal and the vent terminal must terminate on the same exterior wall (same atmospheric pressure zone).

### IMPORTANT

The air intake equivalent vent length must be equal to or less than the exhaust equivalent vent length and the air intake termination elbow shall be equipped with a standard wire mesh screen.

Connect and secure all piping and elbows from the power venter to the wall. When the installation is completed, the vent and air

intake terminals must be at two (2) inches (5.1 cm) from the exterior surface of the wall (**see Figure 2**). Do not extend vent or air intake piping past this length. Make sure that all piping is properly supported. If the venting will pass through an enclosed area, make sure to leave at least one (1) inch (2.5 cm) clearance around the piping for air circulation.

### FOR PVC AND CPVC PIPING: **PVC CPVC**

Make sure that all horizontal runs have a minimum rise of 1/4 inch per foot (21 mm/m) of run (**see Figure 8**). Horizontal runs of vent pipe must be supported every three (3) feet (91 cm).

### FOR POLYPROPYLENE PIPE FROM CENTROTHERM

(InnoFlue single wall vent system): **InnoFlue® Centrotherm**

Make sure that all horizontal runs have a minimum rise of 5/8 inch per foot (56 mm/m) of run. Follow instruction of the vent pipe manufacturer for proper vent support.

### FOR POLYPROPYLENE PIPE FROM DURAVENT

(Polypro single wall gas vent system): **PolyPro® DuraVent**

Make sure that all horizontal runs have a minimum rise of 1/4 inch per foot (21 mm/m) of run. Follow instruction of the vent pipe manufacturer for proper vent support.

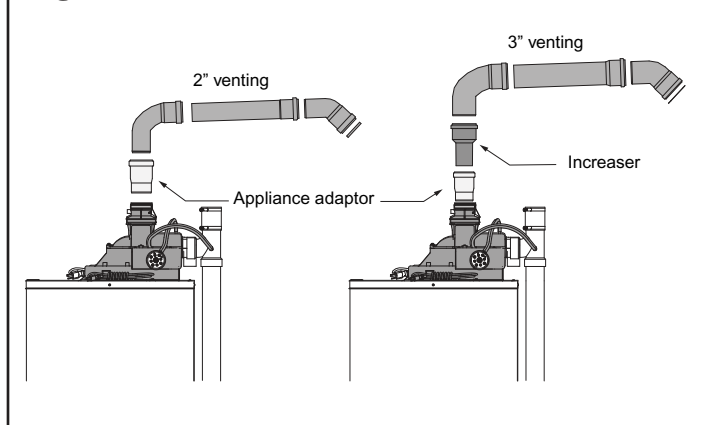
### Concentric Vent Termination Kit Installation

A two (2) inch (5.1 cm) Concentric Vent Termination Kit (IPEX model 196005) (with a two [2] inch [5.1 cm]) restrictor screen from 0 to twenty-five [25] feet [7.6 m]), or a three (3) inch (7.6 cm) Concentric Vent Termination Kit (IPEX model 196006) may be used with a three (3) inch (7.6 cm) restrictor screen for side wall termination installations. Using this Concentric Vent Termination Kit will reduce the maximum allowable equivalent vent pipe length for both air intake and exhaust systems (**see Table 1**). **Figure 7b** illustrates the Concentric Vent Termination Kit for side wall installation. See manufacturer's instructions for complete installation details.

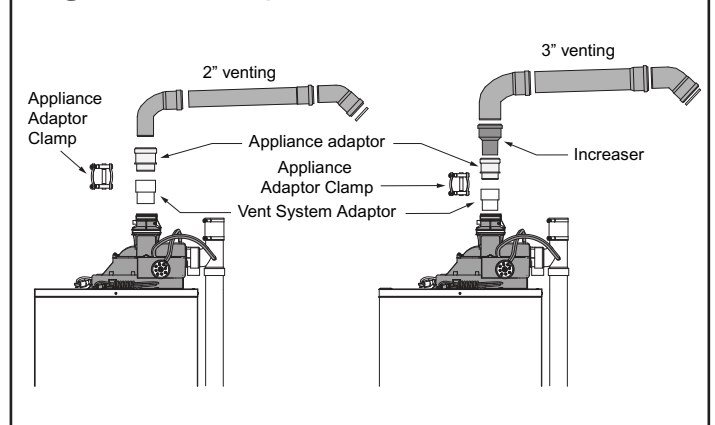
### Through-the-Roof Venting Installation

Cut or drill two (2) holes through the roof and ceiling, slightly larger than the diameter of the vent pipe selected. The larger holes will allow for final alignment with the water heater. Construct the

**Figure 5 — InnoFlue® Centrotherm**



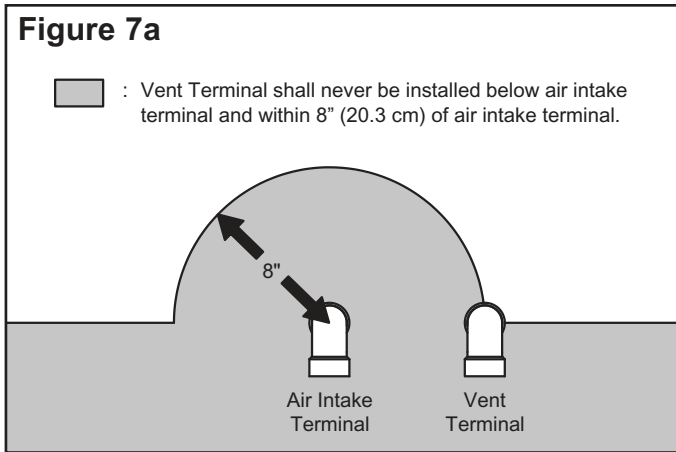
**Figure 6 — PolyPro® DuraVent**





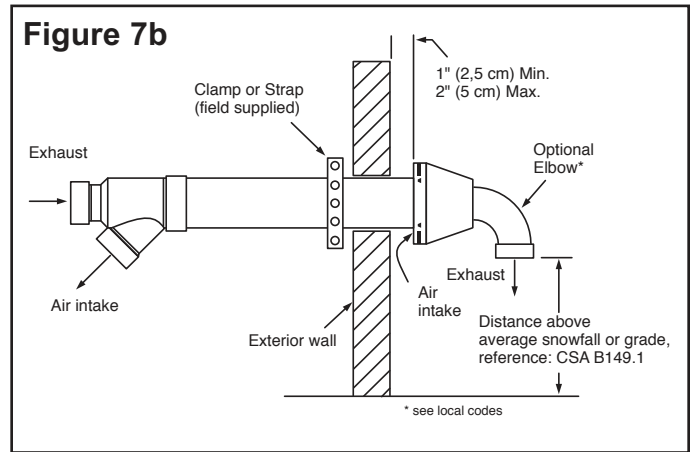
# INSTALLATION INSTRUCTIONS

**Figure 7a**



vent terminal assembly. Extend a section of pipe through each hole in the roof to the outside and attach the terminal assembly to the exterior end of each pipe. The vent and air intake terminals must be at least eight (8) inches (20.3 cm) apart and the vent terminal must **NEVER** be installed below the air intake terminal for any reason (see Figure 2). The air intake terminal and the vent terminal must penetrate the same side of roof and be oriented facing downward in the same direction. Connect and secure all piping and elbows from the power venter to the roof. When the installation is completed, the air intake terminal must be at a minimum of eighteen (18) inches (45.7 cm) from the exterior surface of the roof or anticipated snow accumulation level (see Figure 2). The vertical terminations should be sealed

**Figure 7b**

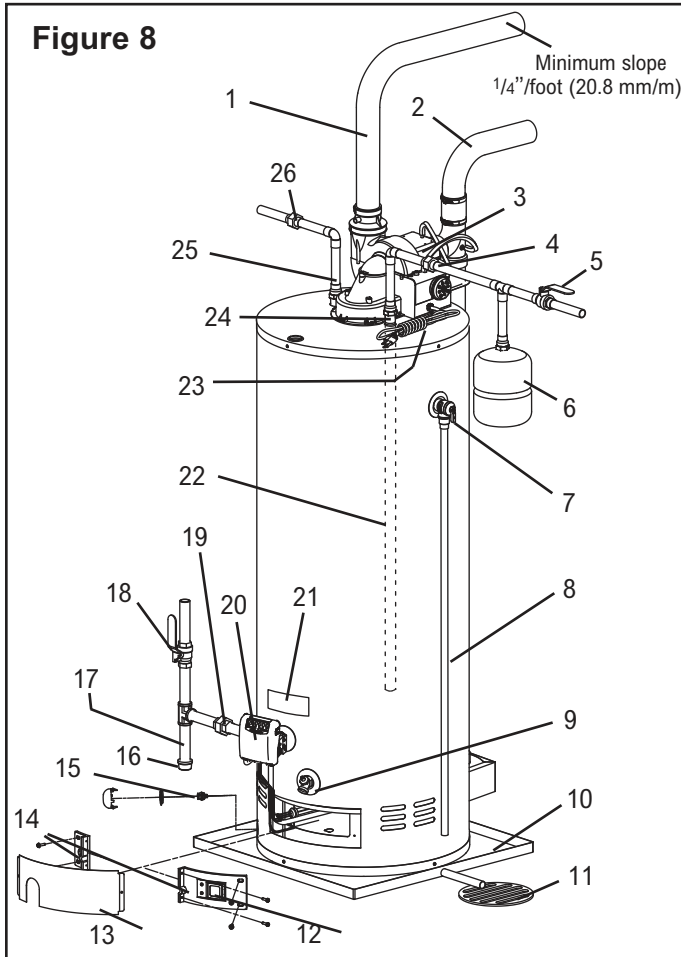


with a plumbing roof boot or equivalent flashing. Make sure that all piping is properly supported. If the venting will pass through an enclosed area, make sure to leave at least one (1) inch (2.5 cm) clearance around the piping for air circulation.

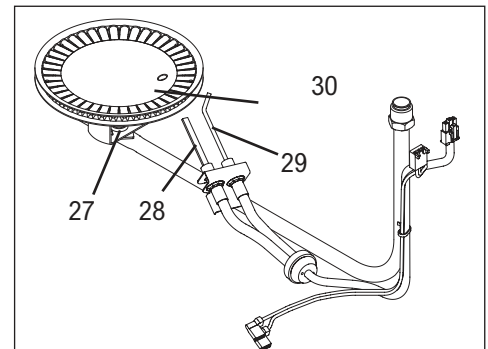
**FOR PVC AND CPVC PIPING:** **PVC** **CPVC**

Make sure that all horizontal runs have a minimum rise of 1/4 inch per foot (21 mm/m) of run (see Figure 8). Horizontal runs of vent pipe must be supported every three (3) feet (91 cm) and vertical runs of vent pipe must be supported every five (5) feet (1.5 m).

**Figure 8**



- |  |                                      |
|--|--------------------------------------|
| 1) Vent pipe                           | 17) Drip leg (Sediment trap)         |
| 2) Air intake pipe                     | 18) Gas supply manual shut-off valve |
| 3) Blower assembly                     | 19) Union                            |
| 4) Union                               | 20) Gas control valve                |
| 5) Cold water manual shut-off valve    | 21) Rating plate                     |
| 6) Expansion tank                      | 22) Dip-tube                         |
| 7) Temperature & pressure-relief valve | 23) Power cord                       |
| 8) Overflow tube                       | 24) Cold water inlet                 |
| 9) Drain valve                         | 25) Hot water outlet                 |
| 10) Drain pan                          | 26) Union                            |
| 11) Free-flowing floor drain           |                                      |
| 12) Sight glass                        | 27) Burner orifice                   |
| 13) Outer access door                  | 28) Ignitor                          |
| 14) Inner access doors                 | 29) Flame sensor                     |
| 15) Flammable vapour sensor            | 30) Burner                           |
| 16) Cap                                |                                      |



# INSTALLATION INSTRUCTIONS

## FOR POLYPROPYLENE PIPE FROM CENTROTHERM

(InnoFlue single wall vent system): **InnoFlue® Centrotherm**

Make sure that all horizontal runs have a minimum rise of 5/8 inch per foot (56 mm/m) of run. Follow instruction of the vent pipe manufacturer for proper vent support.

## FOR POLYPROPYLENE PIPE FROM DURAVENT

(Polypro single wall gas vent system): **PolyPro® DuraVent**

Make sure that all horizontal runs have a minimum rise of 1/4 inch per foot (21 mm/m) of run. Follow instruction of the vent pipe manufacturer for proper vent support.

## Pipe Assembly

### ⚠ WARNING

**ALWAYS** read and abide by all safety messages printed on the primer, cleaner, and cement containers. Primer, cleaner, and cements are extremely flammable. **DO NOT** store these products near heat, sparks, or flames. They are harmful, or fatal if swallowed. Their vapours are also harmful. They may irritate eyes and can be absorbed through the skin. Failure to follow these instructions can result in property damage, personal injury, or death.

## PVC & CPVC VENT SYSTEM: **PVC CPVC**

Primers, cleaners, solvents, and cements are available for PVC and CPVC pipe/fittings. When cementing the pipe/fittings, make sure to use only materials approved for the type of pipe/fittings to be installed and in all cases, follow the vent pipe/fittings manufacturers joining instructions. Never use all-purpose cements, commercial glues, and adhesives to join PVC or CPVC pipe/fittings.

- 1) Adjust the vent pipe length to properly fit the vent system adaptor on the blower assembly outlet.
- 2) Cut pipe ends squarely, removing all burrs and dirt.
- 3) Dry fit the pipe/fitting to be connected to make sure they fit properly.
- 4) Clean the pipe/fitting with the proper primer or cleaner.
- 5) Apply a thin coat of cement to the fitting, avoiding puddling inside.
- 6) Apply a liberal coat of cement to the vent pipe, leaving no voids.
- 7) **QUICKLY** assemble parts while cement is fluid! If you wait too long, re-coat pipe/fitting.
- 8) Push the vent pipe completely into the coupling, turning as it goes until it bottoms out.
- 9) Hold pipe and fitting together for thirty (30) seconds. Then carefully clean off any excess material with a cloth. Allow connections a sufficient time to cure before disturbing.
- 10) Loosen the upper hose clamp on the rubber transition fitting and fully insert the CPVC pipe of the vent system adaptor

one (one [1] inch [2.5 cm]) deep. Do not apply cement to the rubber transition fitting.

- 11) Tighten the upper hose clamp to ensure the vent pipe is firmly secured and gas tight.
- 12) Make sure that the lower hose clamp is firmly seated, secured, and gas tight. Gently move the vent pipe side to side and vertically to ensure that it is securely in place and that there is no slippage.

## POLYPROPYLENE PIPE: **PolyPro® DuraVent InnoFlue® Centrotherm**

Follow the vent pipe manufacturer installation instructions to assemble the vent pipe. Make sure to secure the vent pipe sections together using the mean (connector ring or locking band) as specified by the vent pipe manufacturer.

## Vent Termination Through-The-Wall

### PVC & CPVC VENT SYSTEM: **PVC CPVC**

Two (2) 90-degree PVC elbows are supplied with the water heater and shall be installed at the end of the vent and air intake piping to serve as the termination for through-the-wall installation when the vent system is built with PVC pipes. If CPVC is used to build the vent system, use 90-degree CPVC elbows that are approved to be used with the vent system. A wire mesh screen must be installed in the termination elbows.

### POLYPROPYLENE VENT SYSTEM:

#### **PolyPro® DuraVent InnoFlue® Centrotherm**

A 90-degree Polypropylene elbow, approved to be used with the vent system shall be used as the termination elbow for through-the-wall installation. Be sure to remove the wire mesh screen that was supplied with the 90-degree PVC elbow and insert it into the polypropylene elbow. Push the screen until it locks in place inside the elbow.

## Vent Termination Through-The-Roof

### PVC & CPVC VENT SYSTEM: **PVC CPVC**

Two (2) 90-degree PVC elbows are supplied with the water heater and shall be installed at the end of the vent and air intake piping to serve as the termination for through-the-roof installation when the vent system is built with PVC pipes (**see Figure 3**). If CPVC is used to build the vent system, use 90-degree CPVC elbows that are approved to be used with the vent system. A wire mesh screen must be installed in the termination elbows.

### POLYPROPYLENE VENT SYSTEM:

#### **PolyPro® DuraVent InnoFlue® Centrotherm**

A 90-degree Polypropylene elbow, approved to be used with the vent system shall be used as the termination elbow for through-the-roof installation. Be sure to remove the wire mesh screen that was supplied with the 45-degree PVC elbow and insert it into the polypropylene elbow. Push the screen until it locks in place inside the elbow.

# INSTALLATION INSTRUCTIONS

## ⚠ WARNING

In freezing weather, check for snow accumulation around the water heater vent and air intake terminals where they pass through the outside wall. The open ends of the terminals must be installed at least twelve (12) inches (30 cm) above the highest anticipated snowfall to prevent blockage by snow.

## ⚠ WARNING

Check that all openings and gaps in the outside wall near and around where the vent and air intake pipes pass through the exterior wall are sealed to prevent infiltration of combustion products into the building.

### Restrictor Screens

PVC & CPVC VENT SYSTEM: **PVC CPVC**

Two (2) black restrictor screens (two [2] inches [5.1 cm] and three [3] inches [7.6 cm]) are provided in the box (see **Figure 9**). The two (2) inch (5.1 cm) restrictor screen must be installed in the vent termination elbow when total equivalent length is thirty (30) feet (9.1 m) or less, otherwise a standard wire mesh screen shall be installed. When using a three (3) inch (7.6 cm) vent, the three (3) inch (7.6 cm) restrictor screen must be installed in the vent termination elbow in all cases.

When using a two (2) inch (5.1 cm) concentric vent system from IPEX, be sure to install the two (2) inch (5.1 cm) black restrictor screen from 0 to twenty-five (25) feet (7.6 m). If using the three (3) inch (7.6 cm) concentric vent system from IPEX, be sure to install the three (3) inch (7.6 cm) black restrictor screen in all cases.

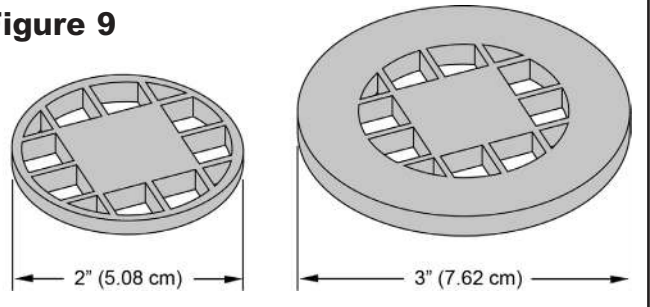
POLYPROPYLENE VENT SYSTEM:

**PolyPro® DuraVent InnoFlue® Centrotherm**

Two (2) grey restrictor screens (two [2] inches [5.1 cm] and three [3] inches [7.6 cm]) are provided in the box (see **Figure 9**). The two (2) inch (5.1 cm) restrictor screen must be installed in the vent termination elbow when total equivalent length is thirty (30) feet (9.1 m) or less, otherwise a standard wire mesh screen shall be installed. When using

a three (3) inch (7.6 cm) vent, the restrictor screen must be installed in the vent termination elbow in all cases. To install the restrictor screen, remove the gasket at the end of the termination elbow and insert the restrictor screen. Push firmly the screen into the elbow pass the gasket groove. Put the gasket back into place.

**Figure 9**



The air intake screen can be removed on the air intake terminal in cold environment. Thus, this may make the air intake susceptible to debris build-up in the air intake pipe. A second screen is installed in the rubber adaptor on the air inlet at the back of the water heater to prevent debris from entering the water heater. This screen can be accessed for cleaning by removing the pipe on top of the rubber adaptor. If the air intake screen is removed to prevent freezing, it is recommended that the air inlet screen be installed during the spring.



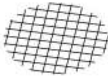
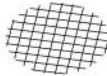

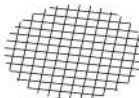
## ⚠ WARNING

When the installation is complete, visually inspect the venting system to make sure that all joints are properly connected and all instructions have been followed. Failure to properly install the venting system could result in property damage, personal injury, or death.

### Condensation in the Venting System

In some installations, condensation will form in the horizontal runs of vent piping. In order to effectively control the condensate from adversely affecting the mechanical components of the water heater (draining back into the blower), a rubber adaptor with a drain outlet is mounted directly on the blower vent outlet. A plastic tube can be attached to this outlet to drain any condensate that has accumulated, away from the water

**Table 4**

VENT SIZE	EQUIVALENT LENGTH	VENT TERMINAL	AIR INTAKE TERMINAL
2" (5.1 cm)	minimum vent to 30' (9.14 m)		
	30' (9.14 m) to 50' (15.2 m)		
3" (7.6 cm)	minimum vent to maximum of 80' (24.4 m)		

# INSTALLATION INSTRUCTIONS

heater. Make sure that the condensate removal tube flows to a suitable free-flowing drain.

## Water Piping

Refer to **Figure 8** for a typical installation. Use of this layout should provide a trouble-free installation for the life of the water heater. Before making the plumbing connections, locate the **COLD** water inlet and the **HOT** water outlet. These fittings are both  $\frac{3}{4}$ " NPT male thread. Make sure that the dip-tube is installed in the cold water inlet. Install a shut-off valve close to the water heater in the cold water line. It is recommended that unions be installed in the cold and hot water lines so that the water heater can be easily disconnected, if servicing is required.

When assembling the hot and cold piping, use a good food grade of pipe joint compound, and ensure all fittings are tight. **DO NOT APPLY HEAT TO THESE FITTINGS** when making sweat connections to the water heater. Sweat tubing to threaded adaptors before connecting to the water heater. **IT IS IMPERATIVE THAT NO HEAT BE APPLIED** to the cold water inlet, as it contains a non-metallic dip-tube. **This will result in premature failure of the fittings, which is not covered by the warranty.**

## Temperature and Pressure-Relief Valve

### ⚠ WARNING

**DO NOT** plug the temperature and pressure-relief valve or its discharge line. **DO NOT** remove the relief valve. Make sure the relief valve is properly sized for the water heater. If the relief valve continuously discharges water, call Enercare Home Services at 1-800-266-3939 to correct the problem. Failure to follow these instructions can result in property damage, personal injury, or death.

To protect from excessive pressure and/or temperature, the manufacturer has installed a temperature and pressure-relief valve that meets the requirements of the Standard for Relief Valves and Automatic Gas Shut-Off Devices for Hot Water Supply Systems, CSA 4.4, in Canada, and ANSI Z21.22, in the United States. This relief valve has a maximum set pressure that does not exceed the hydrostatic working pressure of the water heater (150 psi = 1,035 kPa) and a BTU/hr rating equal to or greater than the input rating, as shown on the water heater rating plate. It should never be plugged or removed from the opening marked for it on the water heater.

If this relief valve should need to be replaced, use only a new temperature and pressure-relief valve. **NEVER** install an old or existing relief valve, as it may be damaged or inadequate for the working requirements of the new water heater. This new relief valve must meet all local codes or, at a minimum, the requirements listed above. **NEVER** install any other type of valve between the relief valve and the water heater.

A discharge line must be installed into the relief valve. The discharge line:

- Must not be smaller than the outlet pipe size of the relief valve.
- Must not terminate less than six (6) inches (15 cm) and not more than twelve (12) inches (30 cm) above floor.
- Must not be restricted in any way. Do not thread, cap, or in any way restrict the end of this outlet.
- Must be of a material capable of withstanding 210°F (99°C) without distortion.
- Must be installed to allow complete drainage of the relief valve and discharge line.
- Must terminate at an adequate free-flowing drain.

## Pressure Build-up in a Water System


When the water heater operates, the heated water expands creating a pressure build-up. This is a natural function and is one of the reasons for installing a temperature and pressure-relief valve. If the cold water supply line has a built-in water meter, check valve, or pressure-reducing valve, a suitable expansion tank must be installed to prevent pressure build-up or water hammer effect. Otherwise, the warranty is void (**see Figure 8**). An indication of pressure build-up is frequent discharges of water from the relief valve. Call Enercare Home Services at 1-800-266-3939. If the relief valve is not defective, the service call may be at the cost of the consumer.

## Filling the Water Heater

### ⚠ WARNING

**NEVER** operate the water heater unless it is completely filled with water. **Failure to follow this instruction can result in premature failure of the water heater that is not covered by the warranty.**

Check that all of the water piping connections have been made. To fill the water heater:

- 1) Make sure that the water heater drain valve is closed by inserting a flat head screwdriver into the slot on the head of the drain valve and turning the knob clockwise .
- 2) Open the cold water supply manual shut-off valve. This valve must remain open, as long as the water heater is in use. **NEVER** operate the water heater with the cold water supply manual shut-off valve closed.
- 3) To make sure the water heater is completely full of water, open all of the hot water faucets in the house to let the air out of the water heater and plumbing system. Leave the faucets open until a constant flow of water is obtained.
- 4) Check all of the plumbing connections to make sure there are no leaks.

# INSTALLATION INSTRUCTIONS

## Gas Connections

### ⚠ WARNING

**DO NOT** attempt to use this water heater with any gas other than the type of gas shown on the water heater rating plate. Failure to follow this instruction can result in property damage, personal injury, or death.

The gas piping must be installed as indicated in **Figure 8**. For the correct size of piping for this water heater, consult the latest edition of CAN/CSA B149.1, National Gas and Propane Installation Codes, in Canada, and/or the latest edition of the National Fuel Gas Code, ANSI Z223.1/NFPA 54, in the United States. Only new piping with cleanly cut threads may be used, together with a suitable sealing compound that is approved for natural and propane gases. It is mandatory that a readily accessible manual shut-off valve be installed in the gas supply line. The gas supply manual shut-off valve must be close to the water heater. A drip leg (sediment trap) must be installed in the gas line ahead of the gas control valve to prevent dirt from entering it. A union must be installed between the gas control valve and the gas supply manual shut-off valve for easy maintenance of the water heater.

The water heater and its gas connection must be leak tested before placing the appliance into operation.

To leak test the system:

### ⚠ WARNING

**NEVER** use an open flame to test for gas leaks. A fire or explosion could occur resulting in property damage, personal injury, or death.

- 1) Turn on the manual gas shut-off valve near the water heater.
- 2) Use a soapy water solution to test all connections and fittings for leaks. Bubbles indicate a gas leak.
- 3) Correct all leaks.

Make sure that the inlet pressure to the water heater does not exceed 0.5 PSI (3.5 kPa) for both natural and propane gases. Pressures in excess of 0.5 PSI (3.5 kPa) can damage the gas control valve, resulting in a fire or explosion from leaking gas. For purposes of adjustment, the minimum inlet pressure is indicated on the water heater rating plate.

If any pressure testing of the gas line is undertaken at test pressures in excess of 0.5 PSI (3.5 kPa), the water heater and its gas supply manual shut-off valve must be disconnected from the gas supply piping system, and the end of the pipe sealed with a female cap. If the testing is to be undertaken at a test pressure less than 0.5 PSI (3.5 kPa), the gas supply manual shut-off valve must be closed.

### ⚠ WARNING

U.L. and CSA recognized fuel gas and Carbon Monoxide (Co) detectors are recommended in all applications and should be installed using the manufacturer's instructions and local codes, rules, or regulations.

### ⚠ WARNING

A high altitude orifice **MUST BE** installed for water heaters operating above 2,000 feet (610 m). Failure to follow this instruction can result in property damage, personal injury, or death.

## Wiring

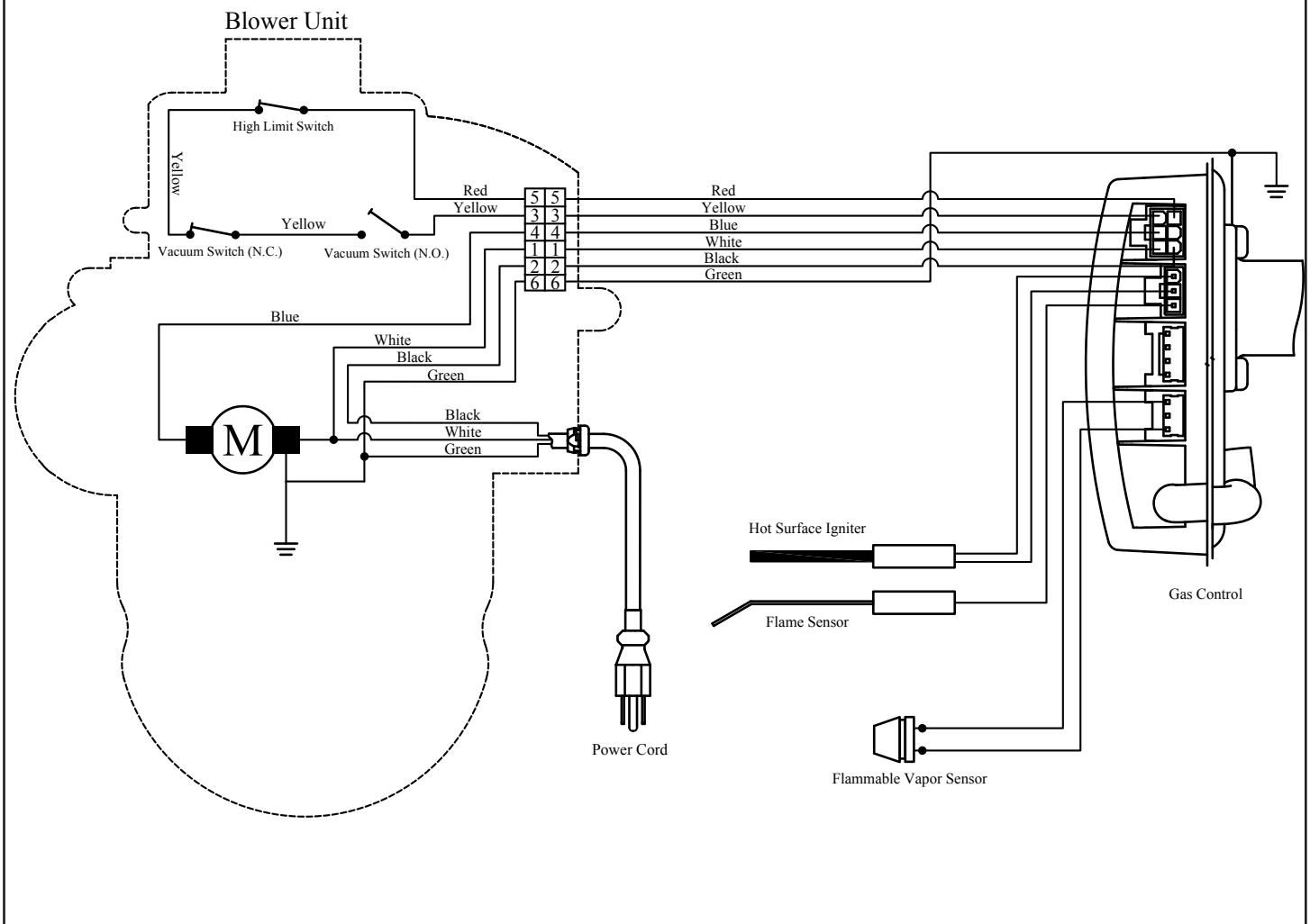
### ⚠ WARNING

This water heater uses an external electrical source for power. It must be electrically grounded in accordance with all local codes or, in the absence of local codes, the latest edition of CSA C22.1 Canadian Electrical Code, in Canada, and/or the latest edition of the National Electrical Code, ANSI/NFPA 70, in the United States. Failure to properly ground this water heater can result in property damage, personal injury, or death.

Before lighting your water heater, check that all of the wires have been installed correctly (**see Figure 10**). Make sure that none of the wires are grounded, have split, or are broken. Verify that all wiring connections are properly secured, as there is a possibility that they have become loose during transport. If any of the original wiring needs replacing, use only 18AWG-type or greater wire that is approved for 221°F (105°C).

# INSTALLATION INSTRUCTIONS

**Figure 10 Wiring Diagram**



## Installation Instructions for Water Heaters Approved for Combination Space Heating and Potable Water Heating (see Figure 11)

A water heater cannot be used for space heating only. When using a water heater for combination space and potable water heating, the instructions provided in this manual and with the air-handling unit must be respected and, **in particular**, the following:

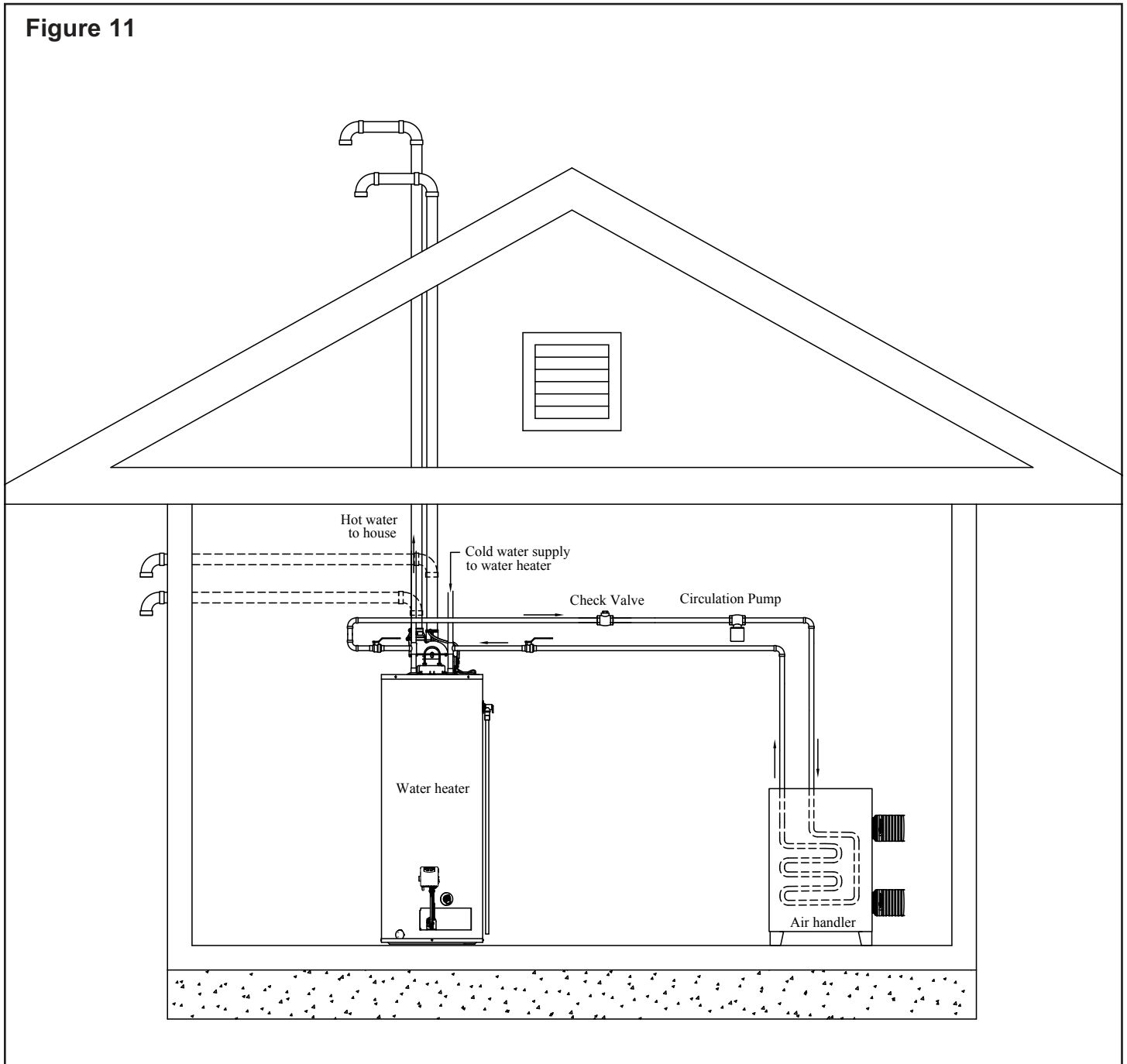
- 1) All piping and components that are used in the system must be of a nonferrous type suitable for potable water. This also applies to any sealant used.
- 2) When used as a dual purpose water heater, it must not be connected to any system that has been previously used for non-potable water heating. This includes any piping because, in all probability, existing piping would have been, in the past, treated with chemicals for cleaning or sealing the system.
- 3) If this water heater is to be used for space heating, make sure that all safety codes are respected. Pay special attention to safety valve pressure and expansion tanks.
- 4) Do not use toxic chemicals to clean the potable water heating system.
- 5) Where water temperature in excess of 140°F (60°C) is required for a space heating application, a mixing valve must be installed in the potable side of the system. This will temper the water and reduce the risk of scalding.
- 6) If the incoming water line to the heater is equipped with a check valve, water meter, or pressure-reducing valve, an expansion tank must be installed in the system. This will prevent weeping from the water heater relief valve and premature failure of the heater due to expansion of the water during the heating cycle.
- 7) Before acquisition of a water heater for space heating application, it is necessary to have the area of intended

# INSTALLATION INSTRUCTIONS

use sized by an Enercare qualified technician. This will ensure that an adequate water heating capacity will be available for both heating and potable water supply, and that the application will meet all local codes and public utility requirements.

**Note:** It is good practice to oversize the water heater, to ensure that all of the potential hot water requirements are available.

**Figure 11**



## Installation Checklist

**Refer to the Enercare Home Services checklist**

# OPERATING INSTRUCTIONS

## Lighting the Water Heater



Lighting or re-lighting your water heater will be done by Enercare Home Services. For any problems occurring after installation, please contact Enercare Home Services at 1-800-266-3939.

## ⚠ WARNING

**DO NOT** light this water heater if:

- It is not full of water.
- The gas supplied does not match the type listed on the rating plate.
- Gasoline or other flammable vapours and liquids have been stored in the vicinity of the water heater.

Failure to follow these instructions can result in property damage, personal injury, or death.

## Lighting Instructions

### FOR YOUR SAFETY READ BEFORE OPERATING

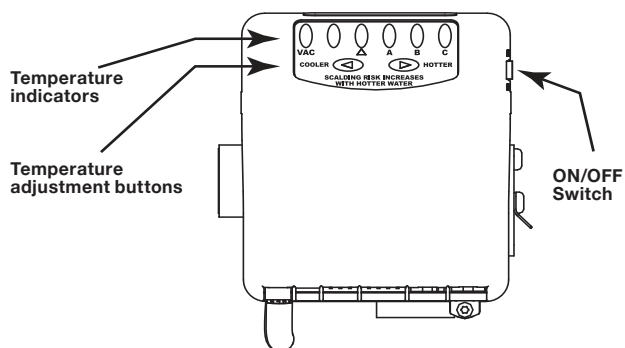
**WARNING: If you do not follow these instructions exactly, a fire or explosion may result causing property damage, personal injury, or loss of life.**

- A.** This appliance does not have a pilot. It is equipped with an ignition device which automatically lights the burner. **DO NOT** try to light the burner by hand.
- B. BEFORE OPERATING** - Smell all around the appliance area for gas. Be sure to smell next to the floor because some gas is heavier than air and will settle on the floor.
- WHAT TO DO IF YOU SMELL GAS:**
- **DO NOT** try to light any appliance.
  - **DO NOT** touch any electric switch; **DO NOT** use any phone in your building.
  - Immediately call your gas supplier from a neighbor's phone. Follow the gas supplier's instructions.

- If you cannot reach your gas supplier, call the fire department.
- C.** Use only your hand to push in the gas control buttons. Never use tools. If the control buttons will not push in, don't try to repair them, call Enercare Home Services at 1-800-266-3939. Force or attempted repair may result in fire or explosion.
- D.** Do not use this appliance if any part has been under water. Immediately call Enercare Home Services at 1-800-266-3939 to replace a flooded water heater. Do not attempt to repair the unit! It must be replaced!

## OPERATING INSTRUCTIONS

1. **STOP!** Read the safety information above on this label.
2. Toggle the "ON/OFF" switch located on the gas control to the "ON" position.
3. Set the thermostat to the lowest setting by pressing the COOLER ◀ and HOTTER ▶ buttons at the same time and holding them for one (1) second. Then press the COOLER ◀ button until only the VAC indicator light is lit.
4. Toggle the "ON/OFF" switch located on the gas control to the "OFF" position.



5. Turn off all electrical power to the appliance.
6. This appliance is equipped with an ignition device which automatically lights the burner. **DO NOT** try to light the burner by hand.
7. Wait five (5) minutes to clear out any gas. Then smell for gas, including near the floor. If you smell gas, **STOP!** Follow step "B" in the safety information above on this label. If you do not smell gas, go to the next step.
8. Turn on all electrical power to the appliance.
9. Toggle the "ON/OFF" switch located on the gas control to the "ON" position.
10. Set thermostat to the desired temperature setting by pressing the COOLER ◀ and HOTTER ▶ buttons at the same time and holding them for one (1) second. Then press the HOTTER ▶ button until the desired temperature display setting is lit. The preferred starting point for temperature setting is indicated by ▲ on the thermostat.
11. If the appliance will not operate, follow the instructions "TO TURN OFF GAS TO APPLIANCE" and call Enercare Home Services at 1-800-266-3939.

### TO TURN OFF GAS TO APPLIANCE

1. Set the thermostat to the lowest setting by first pressing the COOLER ◀ and HOTTER ▶ buttons at the same time and holding for one (1) second. Then press the COOLER ◀ button until only the VAC indicator light is lit.
2. Toggle the "ON/OFF" switch located on the gas control to the "OFF" position.
3. Turn off all electrical power to the appliance.



# OPERATING INSTRUCTIONS

## Water Temperature Regulation

### ⚠ WARNING

The higher the temperature setting, the greater the risk of scalding. Hot water can cause third degree burns in under one (1) second at 160°F (71°C), in five (5) seconds at 140°F (60°C), and in thirty (30) seconds at 130°F (54°C). In households where there are children, physically challenged individuals, or seniors, mixing valves for point of use are necessary as means of reducing the scalding potential of hot water.

When the water heater is plugged in for the first time, the gas control valve will start to heat the water to the factory adjusted temperature. To avoid any unintentional changes in the water temperature settings, the gas control valve has a tamper-resistant feature included for changing the temperature setting. If you want to change this setting for either cooler or warmer water, the following steps are necessary:

1. “Wake up” the temperature indicators by holding down both the **COOLER** and **HOTTER** temperature adjustment buttons at the same time for one (1) second (see Lighting Instructions). One or two of the temperature indicators will light up. These indicators will only remain on for thirty (30) seconds, if no further buttons are pressed. After thirty (30) seconds, the control will go back to “Sleep” mode, and both buttons will again have to be pressed to see the water temperature setting. Release both of the temperature adjustment buttons. **See Figure 12** for an explanation of what each of the temperature indicators mean.

**Figure 12**

DISPLAY						APPROXIMATE TEMPERATURE °F (°C)	APPROXIMATE TIME TO CAUSE INJURY
▼	A	B	C				
●	○	○	○	○	○	70 (21) (Vacation)	N/A
○	●	○	○	○	○	110 (43)	5 Minutes
○	○	●	○	○	○	115 (46)	
○	○	○	●	○	○	120 (49)	30 Seconds
○	○	○	○	●	○	125 (52)	
○	○	○	○	○	●	130 (54)	
○	○	○	○	○	○	135 (57)	5 Seconds
○	○	○	○	○	○	140 (60)	1.5 Seconds
○	○	○	○	○	○	145 (63)	
○	○	○	○	○	○	150 (66)	
○	○	○	○	○	○	160 (71)	Under 1 Second

FLASHING →

**To decrease the temperature**, press and release the **COOLER** button once. The temperature indicators will now display the new temperature setting. Press and release the **COOLER** button until you have reached the desired setting. **HOLDING DOWN THE**



**BUTTON WILL NOT CONTINUE TO LOWER THE SETTING.** The button must be pressed and released for each temperature change desired.

**To increase the temperature**, press and release the **HOTTER** button once. The temperature indicators will now display the new temperature setting. Press and release the **HOTTER** button until you have reached the desired setting. **HOLDING DOWN THE BUTTON WILL NOT CONTINUE TO RAISE THE SETTING.** The button must be pressed and released for each temperature change desired.

To maximize the efficiency of this water heater and reduce the risk of scalding, it is recommended that the gas control valve be set at the setting below the large triangle («▼»), which represents approximately 120°F (49°C).

2. When you have completed setting the control, wait thirty (30) seconds to see that the temperature indicators go off and the control enters “Sleep” mode. **ALL OF THE TEMPERATURE INDICATORS WILL BE OFF DURING NORMAL OPERATION.** If at any time you see the indicators on, there may be a problem with the water heater and you should consult the Troubleshooting Guide of this document, or call Enercare Home Services at 1-800-266-3939.

When hot water is drawn from the tank in frequent short bursts, a condition known as “stacking” is created. “Stacking” is the result of increased cycling of the burner and can produce very hot water temperatures at the hot water outlet. Always remember to check the hot water coming out of any faucet with your hand before use. This will reduce the risk of scalding-related injuries.

The gas control valve pictured in this manual is equipped with a resettable type automatic high temperature cut-off. Should the temperature of the water exceed 195°F (91°C),

# OPERATING INSTRUCTIONS

the high temperature cut-off will automatically shut off the gas supply to the water heater. If this situation occurs, the gas control valve must be immediately replaced by Enercare.

## ⚠ WARNING

Should overheating occur or the gas supply fail to shut-off, close the gas supply manual shut-off valve. Failure to follow this instruction can result in property damage, personal injury, or death.

### Out of Fuel

If your water heater should run out of gas, call Enercare Home Services at 1-800-266-3939 and let them know your situation.

### Housekeeping

Keep the area around the water heater clean and free of dust, lint, and dirt. It is the responsibility of the homeowner to do so in order to prevent any malfunction that is not Enercare's responsibility.

## ⚠ WARNING

**DO NOT** store or use gasoline or other flammable vapours and liquids around the water heater.

**DO NOT** put or store any objects on the top of the water heater. Failure to follow these instructions can result in property damage, personal injury, or death.

### Flammable Vapour Sensor

This water heater is equipped with a flammable vapour sensor (FV) that will shut it down in the event of a flammable vapour incident. It is a safety feature that may prevent property damage, personal injury, or death.

The FV sensor is located on the front left bottom of the exterior casing of the water heater. The FV sensor is protected from shock and contaminants by a robust plastic cover. The function of the FV sensor is to detect the presence of flammable vapours before they enter the combustion chamber and ignite. If the FV sensor detects the presence of flammable vapours while the water heater is operating, the gas control will switch to lock-out mode and the water heater will shut down. If the water heater is not operating when the flammable vapours are detected, the control will switch to lock-out mode and prevent the water heater from lighting. After a flammable vapour incident has occurred and the flammable vapours have dissipated, the FV sensor is designed to automatically reset itself. The Emerson gas control however, will have gone into lock-out mode and will need to be manually reset. An Enercare qualified service technician must be called to determine if flammable vapours entered the combustion chamber and ignited. In most instances, there will not have been ignition of flammable vapours inside the combustion chamber because the FV sensor will have detected these vapours and shut down

the water heater. In this case, the Emerson gas control can be reset and the water heater may resume normal operation. On the other hand, if the flammable vapours ignited inside the combustion chamber, the water heater may need to be replaced. The Enercare technician will be able to determine whether or not the water heater needs to be replaced based on the amount of flammable vapours that entered the combustion chamber and the damage to the water heater from the resulting fire.

### Condensation

As moisture from the products of combustion comes into contact with the cold surface of the inner tank, it may condense. This situation will usually occur:

- 1) When the water heater is filled with cold water for the first time.
- 2) If the water heater has been undersized.
- 3) When large amounts of hot water are drawn from the water heater in a short period of time, and the refill water is very cold.

Due to the high-efficiency rating of this gas-fired water heater, it may produce more condensation than older models. Condensation forming on the flue tube will drop on the burner making a "sizzling" sound. This condition is not uncommon and must never be misinterpreted as a leaking tank. It will disappear once the water becomes heated.

Because of the large amounts of water that can condense, it is very important that a drain pan be installed under the water heater (**refer to Figure 8**). **Under no circumstances is the manufacturer to be held liable for any water damage, in connection with this water heater.**

### Burner Ignitor Assembly

Every three (3) months, check the burner and flame ignitor assembly. Remove the outer access door and look through the sight glass to examine the flames. A soft blue flame indicates proper gas combustion. A yellow tipped flame indicates poor combustion. With a vacuum cleaner, remove any dust, lint, and dirt accumulation on or around the combustion chamber.

If the poor combustion persists and there is no lint around the water heater, call Enercare Home Services at 1-800-266-3939. This service call may be at the expenses of the consumer if lint is blocking the flame arrestor plate.

### Water Heater Tank

You may choose to drain the tank at your convenience in very hard water conditions.

### Temperature and Pressure-Relief Valve

On a regular basis, visually inspect the relief valve for any leakage. If so, call Enercare Home Services at 1-800-266-3939.

# OPERATING INSTRUCTIONS

## Venting System Inspection

The venting system must be thoroughly inspected once a year. Check the venting system to make sure that all of the connections are securely fastened, and that all of the joints are properly sealed. If any part of the venting system is damaged, it must be replaced by Enercare Home Services at 1-800-266-3939.

## Anode

### ⚠ WARNING

The cap covering the anode on top of the water heater **MUST BE** put back in place after servicing the anode.

This water heater is equipped with an anode that is designed to prolong the life of the glass-lined tank. The anode is slowly consumed, protecting the glass-lined tank from corrosion. The anode should be checked every two (2) years. If you get rotten egg smell, call Enercare Home Services at 1-800-266-3939 that may have a solution to your water condition problem (See the explanation of rotten eggs smell below).

The life expectancy of the water heater is reduced where a water softener is introduced to fight hard water, because the sodium salts added by a softener make this water extremely conductive. In these conditions, the anode is consumed more rapidly and should be verified every year. Please advise Enercare that you operate a water softener so they can take the proper precaution.

In certain water conditions, the anode will react with the water, producing discoloured or smelly water. The most common observation is hot water that smells like rotten eggs. This phenomenon is the result of the reaction between the anode and hydrogen sulfide gas dissolved in the water, which occurs frequently in well systems. This problem can usually be eliminated or reduced by changing the anode to a type more suitable for these conditions (aluminum anode) and by chlorinating the water heater and plumbing system. If the problem persists, special filtration equipment may be required. Under no circumstances is the anode to be removed from the water heater on a permanent basis. **Removal of the anode will lead to premature failure of the water heater and void the warranty.**


This is not an Enercare issue but a consumer issue in the water supply and the consumer is responsible for any apparatus needed to remove the rotten egg smell.

### ⚠ WARNING

Hydrogen gas can be produced in a hot water system that has not been used for a long period of time (generally two [2] weeks or more). **HYDROGEN GAS IS EXTREMELY FLAMMABLE.** It is highly recommended to open the hot water faucet in the kitchen for several minutes before you use any electrical appliances connected to the hot water system, such as a dishwasher or washing machine. If hydrogen gas is present, there will be an unusual sound, such as air escaping through the pipe, as the hot water faucet is opened. **DO NOT** smoke or introduce an open flame near the faucet when it is opened.

## Draining the Water Heater

To completely drain the water heater:

- 1) Toggle the "ON/OFF" switch located on the gas control to the "OFF" position.
- 2) Unplug the power cord from the wall socket.
- 3) Close the gas supply manual shut-off valve.
- 4) Close the cold water supply manual shut-off valve.
- 5) Connect one end of a garden hose to the water heater drain valve and put the other next to a free-flowing drain.
- 6) Open the drain valve by inserting a flat-head screwdriver into the slot on the head of the drain valve and turn the knob counterclockwise .
- 7) Open a hot water faucet to allow air into the system.

## Vacation

If you are planning a vacation or other prolonged absence, it is highly recommended to shut-off the gas supply and the cold water supply to the water heater. This will save energy, protect against property damage in the event the water heater leaks, and prevent the build-up of hydrogen gas. If the water heater and piping are exposed to freezing temperatures, they should both be drained.

Remember to check the water heater thoroughly after it has been shut-off for an extended period of time before putting it back in operation. Make sure that the water heater is completely full of water, and that the cold water supply manual shut-off valve is open, before lighting the burner.

## Getting Service for your Water Heater

If you are having problems with your water heater, please call Enercare Home Services at 1-800-266-3939. Have handy the following:

- a) Name.
- b) Address.
- c) Contract number.
- d) Telephone number.
- e) Other people to reach in case of emergency.
- f) A description of the problem.

# TROUBLESHOOTING GUIDE

## ⚠ WARNING

Disconnect the electrical power before servicing the water heater. Service should only be performed by Enercare Home Services at 1-800-266-3939. Failure to follow these instructions can result in personal injury and/or death.

CONDITION (code#)	CAUSE	REMEDY
	<b>1</b> An open earth ground circuit to the ignition.	<ol style="list-style-type: none"> <li>1) Check that the earth ground conductor is properly connected at the fuse box or breaker panel and the water heater.</li> <li>2) Check that the grounding conductors on the water heater are properly connected and secure.</li> </ol>
	<b>2</b> A wiring error or a high resistance to earth ground.	<ol style="list-style-type: none"> <li>1) Check for proper connection of the line neutral and line hot wires.</li> <li>2) Check that the water heater is securely connected to earth ground.</li> </ol>
	<b>3</b> The pressure switch remained closed longer than five (5) seconds after the call for heat began.	<ol style="list-style-type: none"> <li>1) The pressure switch wiring is incorrect.</li> <li>2) The pressure switch is defective and must be replaced.</li> </ol>
	<b>4</b> The pressure switch remained open longer than five (5) seconds after the power venter was energized. (see note at the bottom of the page)	<ol style="list-style-type: none"> <li>1) The pressure switch wiring is incorrect.</li> <li>2) The pressure switch tubing is not properly connected.</li> <li>3) There are obstructions or restrictions in the water heater air intake or exhaust flue.</li> </ol>
	<b>5</b> The self diagnosing test has detected an error in the hot surface ignitor circuit.	<ol style="list-style-type: none"> <li>1) Check the wiring is correct and secure.</li> <li>2) Disconnect the ignitor connector and measure the ignitor resistance with an accurate ohmmeter between pins 1 and 2. Resistance should be between 11.5 and 18.8 ohms. If the reading is incorrect, replace the hot surface ignitor.</li> <li>3) If the above checks are good, replace the gas control valve.</li> </ol> 
	<b>6</b> The maximum number of ignition retries or recycles has been reached and the system is in lock-out mode.	<ol style="list-style-type: none"> <li>1) Check if the gas supply is off or too low to operate.</li> <li>2) Check the flame sensor rod to see if it is located properly and free from contamination. Reposition the flame sensor rod or lightly clean it with an abrasive cloth.</li> <li>3) The hot surface ignitor may not be positioned correctly. Reposition as necessary.</li> <li>4) Check that the hot surface ignitor and flame sensor rod are wired correctly and in good working condition.</li> <li>5) Low voltage to the water heater. Check and repair.</li> </ol>
	<b>7</b> The gas valve driver circuit.	<ol style="list-style-type: none"> <li>1) Turn off the power to the water heater for ten (10) seconds and then back on.</li> <li>2) If the above step did not clear the error, replace the gas control valve.</li> </ol>
	<b>8</b> The internal microcomputer.	<ol style="list-style-type: none"> <li>1) Turn off the power to the water heater for ten (10) seconds and then back on.</li> <li>2) If the above step did not clear the error, replace the gas control valve.</li> </ol>
	<b>9</b> The internal circuit.	<ol style="list-style-type: none"> <li>1) Turn off the power to the water heater for ten (10) seconds, verify the polarity and then back on.</li> <li>2) If the above step did not clear the error, replace the gas control valve.</li> </ol>
	<b>10</b> Flame signal sensed out of proper sequence.	Replace the gas control valve.
	<b>11</b> The high temperature thermal cut-off is open.	Replace the gas control valve.
	<b>12</b> One of the temperature adjust buttons is stuck closed.	<ol style="list-style-type: none"> <li>1) Make sure that there are no objects leaning against the front of the control.</li> <li>2) Lightly press and release each of the buttons once.</li> <li>3) If the above actions do not clear the error, the control will continue to regulate the water temperature at the last setting, but you will not be able to change settings unless you replace the gas control valve.</li> </ol>
	<b>13</b> The water temperature sensor is either open or short-circuited.	<ol style="list-style-type: none"> <li>1) Check that all of the wiring is correct and that there are no open or short circuits.</li> <li>2) If no wiring problems are found, the gas control valve must be replaced.</li> </ol>
	<b>14</b> The self-diagnosing test found a problem with the flammable vapour sensor.	<ol style="list-style-type: none"> <li>1) Check that all wiring is correct and that there are no open or short circuits.</li> <li>2) If no wiring problems are found, the flammable vapour sensor must be replaced.</li> </ol>
	<b>15</b> The control detected the presence of flammable vapours near the appliance and entered lock-out mode.	<ol style="list-style-type: none"> <li>1) Identify the source of the flammable vapours and remove it from the area surrounding the water heater.</li> <li>2) Contact an Enercare service technician to have the water heater inspected immediately.</li> </ol>
	<b>16</b> Weak Flame Current.	<ol style="list-style-type: none"> <li>1) Check that the flame sense rod to see if it is properly located and free from contamination. Reposition the flame sense rod or lightly clean with an abrasive cloth.</li> <li>2) Low voltage to the water heater. Check and repair.</li> </ol>

**Note for models with a manual reset only:** Since the high limit switch on the blower is in series with the pressure switch, the problem could be that the high limit switch tripped. Reset the high limit Switch by pressing on the red button in the middle of the switch.

# TROUBLESHOOTING GUIDE

Only Enercare Home Services personnel can service your rental water heater, call 1-800-266-3939 for service.

CONDITION	CAUSE	REMEDY
<b>The burner will not ignite.</b>	No gas.	Check with gas utility company.
	Dirt in gas line.	Notify utility. Install drip leg in gas line.
	Air intake terminal is blocked.	Check outside for debris in the terminal or frozen air intake terminal and remove.
	Main burner line clogged.	Clean. Check for source of trouble and correct.
	Defective flame sensor.	Replace with new flame sensor.
	Defective gas control valve.	Replace with new gas control valve.
	Gas control valve set too low.	Turn temperature dial to desired temperature.
<b>The burner flame floats and lifts off ports.</b>	High gas pressure.	Check with gas utility company.
	Orifice too large.	Replace with correct orifice.
	Flue clogged.	Clean. Check for source of trouble and correct.
	Air intake terminal is blocked.	Check outside for debris in the terminal and remove.
	Cold drafts (downdraft).	Locate source and correct.
<b>The burner flame is yellow and lazy.</b>	Insufficient secondary air.	Check that the air intake terminal is not blocked.
	Flue clogged.	Clean. Check for source of trouble and correct.
	Air intake terminal is blocked.	Check outside for debris in the terminal and remove.
	Main burner line clogged.	Clean. Check for source of trouble and correct.
<b>The burner flame is too high.</b>	Insufficient secondary air.	Check that the air intake terminal is not blocked.
	Orifice too large.	Replace with correct orifice.
	Defective gas control valve.	Replace with new gas control valve.
<b>The flame burns at the orifice.</b>	Low gas pressure.	Check with gas utility company.
	Defective gas control valve.	Replace with new gas control valve.
<b>High operating costs.</b>	Gas control valve set too high.	Turn temperature dial to desired temperature.
	Sediment or lime in tank.	Drain. Check to see if water treatment is necessary.
	Water heater is undersized.	Install size of water heater that meets demand.
	Wrong piping connections.	Correct piping, dip-tube must be in cold inlet.
	Leaking faucets.	Repair faucets.
	Gas leaks.	Check with gas utility company. Repair at once.
	Wasted hot water.	Advise consumer.
	Long runs or exposed piping.	Insulate piping.
<b>Insufficient hot water.</b>	Hot water piping on outside wall.	Insulate piping.
	Low gas pressure.	Check with gas utility company.
	Wrong piping connections.	Correct piping, dip tube must be in cold inlet.
	Sediment or lime in tank.	Drain. Check to see if water treatment is necessary.
	Water heater is undersized.	Install the size of water heater that meets the demand.
	Gas control valve set too low.	Turn temperature knob to desired temperature.
	Leaking faucets.	Repair faucets.
	Wasted hot water.	Advise consumer.
	Long runs or exposed piping.	Insulate piping.
<b>Slow hot water recovery.</b>	Hot water piping on outside wall.	Insulate piping.
	Insufficient secondary air.	Check that the air intake terminal is not blocked.
	Low gas pressure.	Check with gas utility company.
	Gas control valve set too low.	Turn temperature dial to desired temperature.
	Improper calibration.	Replace gas control valve.
	Flue clogged.	Clean. Check for source of trouble and correct.
	Water heater is undersized.	Install size of water heater that meets demand.
Wrong piping connection.	Correct piping, dip tube must be in cold inlet.	
Wasted hot water.	Advise consumer.	

# TROUBLESHOOTING GUIDE

Only Enercare Home Services personnel can service your rental water heater, call 1-800-266-3939 for service.

CONDITION	CAUSE	REMEDY
<b>Leaking water.</b>	Poorly sealed, hot or cold water connections, gas control valve threads, relief valve, or drain valve.	Tighten threaded connections.
	Leakage from plumbing system or other appliances.	Inspect plumbing system and other appliances.
	Condensation.	Refer to <b>Condensation</b> .
<b>Water drips from the relief valve.</b>	Heater stacking.	Lower gas control valve setting.
	Excessive water pressure.	Install a pressure-reducing valve.
	Thermal expansion in a closed water system.	Install an expansion tank.
	Improperly seated valve.	Check relief valve works properly and replace, if necessary.
<b>The gas control valve fails to shut off.</b>	Defective gas control valve.	Replace with new gas control valve.
	Improper calibration.	Replace gas control valve.
<b>Condensation.</b>	Water heater filled for the first time.	Let water heater warm up. Problem should go away. If it persists, check all plumbing connections for leaks.
	Heavy draws of hot water with very cold refill water.	Let water heater warm up. Problem should go away. If it persists, check all plumbing connections for leaks.
	Water heater is undersized.	Install size of water heater that meets demand.
<b>Combustion odours.</b>	Insufficient secondary air.	Check that the air intake terminal is not blocked.
	Flue clogged.	Clean. Check for source of trouble and correct.
<b>Smoking and carbon formation (sooting).</b>	Insufficient secondary air.	Check that the air intake terminal is not blocked.
	Low gas pressure.	Check with gas utility company.
	Burner flame yellow, lazy.	Refer to <b>The burner flame is yellow and lazy</b> .
	Flue clogged.	Clean. Check for source of trouble and correct.
	Defective gas control valve.	Replace with new gas control valve.
<b>Smelly water.</b>	High sulfate or mineral content in water.	Change magnesium anode to an aluminum anode and bleach tank.





**enercare™**

**enercare.ca**

™Enercare and the design are trademarks of Enercare Inc., used under license.