

RESIDENTIAL GAS-FIRED POWER VENT WATER HEATERS (EQUIPPED WITH FVIR TECHNOLOGY)

OWNER'S MANUAL INSTALLATION AND OPERATING INSTRUCTIONS

PV 2" Model only
with Emerson
Intelli-Vent™ Gen II
gas control

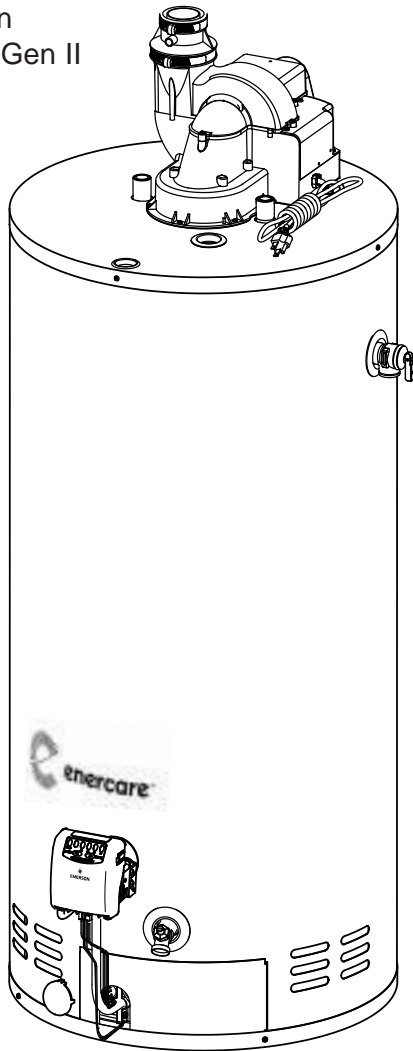

⚠ WARNING

This water heater **IS NOT** design certified for installation in a manufactured (mobile) home or for installation outdoors.

⚠ WARNING

If the information in these instructions is not followed exactly, a fire or explosion may result causing property damage, personal injury, or death.

DO NOT store or use gasoline or other flammable vapours and liquids in the vicinity of this or any other appliance.

WHAT TO DO IF YOU SMELL GAS

- **DO NOT** try to light any appliance.
- **DO NOT** touch any electrical switch.
- **DO NOT** use any phone in your building.
- **From a neighbour's phone, immediately call your gas supplier.** Follow their instructions.
- If you cannot reach immediately the above supplier, call the fire department at 911.

Installation and service must be performed by Enercare Home Services at 1-800-266-3939.

IMPORTANT

READ THESE INSTRUCTIONS CAREFULLY BEFORE BEGINNING THE INSTALLATION. PROPER INSTALLATION WILL PROVIDE SAFE AND EFFICIENT SERVICE AND AVOID NEEDLESS EXPENSE NOT COVERED BY THE WARRANTY. SHOULD YOU HAVE ANY QUESTIONS, PLEASE CONTACT ENERCARE HOME SERVICES AT 1-800-266-3939. **SAVE THIS MANUAL FOR FUTURE REFERENCES.**



TABLE OF CONTENTS

Safety Information	3	Installation Instructions for Water Heaters	
Installation Instructions	4	Approved for Space Heating and Potable	
Altitude	4	Water Heating	16
Location	4	Wiring	16
Minimum Clearances	4	Wiring Diagram	17
Combustion and Ventilation Air Supply	4	Installation Checklist	17
Requirements for Unconfined Spaces	5	Operating Instructions	18
Requirements for Confined Spaces	5	Operating the Water Heater	18
Louvers and Grilles	6	Water Temperature Regulation	19
Corrosive Atmospheres	6	Out of Fuel	20
Venting	7	General Maintenance	20
Venting Connection to the Water Heater	7	Housekeeping	20
Through-the-Wall Venting Installation	9	Safety System	20
Through-the-Roof Venting Installation	9	Condensation	21
Pipe Assembly	10	Burner Ignitor Assembly	21
Vent Termination Through-The-Wall	11	Temperature and Pressure-Relief Valve	21
Vent Termination Through-The-Roof	12	Venting System Inspection	21
Restrictor Screens	12	Anodes	21
Condensation in the Venting System	14	Draining the Water Heater	22
Water Piping	14	Vacation	22
Temperature and Pressure-Relief Valve	14	Service Procedure	22
Pressure Build-up in a Water System	15	Replacement Parts	23
Filling the Water Heater	15	Troubleshooting Guide	24
Gas Connections	15	Model Dimensions	27

FVIR technology equipped with a flammable vapour sensor and a flame arrestor.

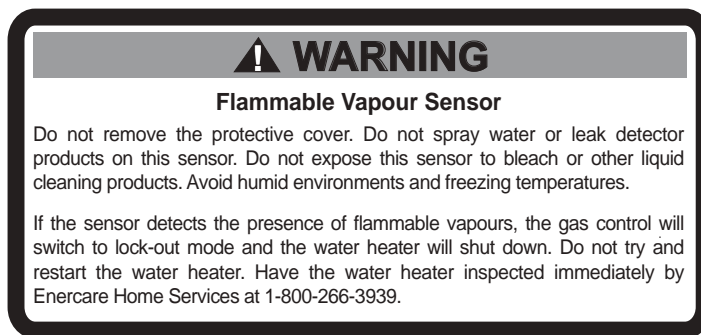

This water heater is equipped with the FVIR technology. Activation of the FVIR technology occurs when flammable vapours are drawn into the water heater. If the flammable vapour sensor detects the presence of flammable vapours when the water heater is operating, the gas control will switch to lock-out mode and the water heater will shut down. If the water heater is not operating when the flammable vapours are detected, the control will switch to lock-out mode and prevent the water heater from lighting. If the flammable vapours enter the combustion chamber and ignite, the flame arrestor will prevent these combustible vapours from igniting outside of the water heater.

If flammable vapours are detected:

- **DO NOT** try to light any appliance.
- **DO NOT** touch any electrical switch. **DO NOT** use any phone in your building.
- **From a neighbour's phone, immediately call your gas supplier.** Follow their instructions.
- If you cannot reach this supplier, call the fire department at 911.

Immediately contact Enercare Home Services at 1-800-266-3939. **Replacement of a FVIR technology equipped water heater due to a flammable vapour shutdown is not covered under the Enercare Home Services rental program and service agreement.**

SAFETY INFORMATION

Your safety and the safety of others is extremely important during the installation, operation and servicing of this water heater. Many safety-related messages have been provided in this manual and on your water heater. Always read and abide by all safety messages. These messages will point out the potential hazard, tell you how to reduce the risk of injury and tell you what will happen if the instructions are not followed.



This is the safety alert symbol. This symbol alerts you to potential hazards that can kill or hurt you and others. All safety messages will follow the safety alert symbol and either the word “DANGER” or “WARNING”.



DANGER

Serious injury or death can occur if you do not follow the instructions **immediately**.



WARNING

Serious injury or death can occur if you do not follow the instructions.



WARNING



FIRE AND EXPLOSION HAZARD

Can result in serious injury or death

! Do not store or use gasoline or other flammable vapours and liquids in the vicinity of this or any other appliance. Storage or use of gasoline or other flammable vapours or liquids in the vicinity of this or any other appliance can result in serious injury or death.

! WARNING

DO NOT use this water heater if any part has been under water. Immediately call Enercare Home Services at 1-800-266-3939 to inspect the water heater. Enercare Home Services will have the final decision as to how to handle the situation.

INSTALLATION INSTRUCTIONS

IMPORTANT

These instructions have been written as a guide for the proper installation and operation of your water heater and the manufacturer of this water heater will not accept any liability where these instructions have not been followed. However, for your safety and to avoid damage caused by improper installation, this water heater must be installed by an Enercare Home Services Certified Licensed Professional, and meet all local codes or, in the absence of local codes, CSA B149.1, Natural Gas and Propane Gas Installation Code, in Canada and/or the National Fuel Gas Code, ANSI Z223.1/NFPA 54, in the United States.

Before proceeding with the installation instructions:

- 1) Inspect the water heater and its component parts for possible damage. **DO NOT** install or attempt to repair any damaged component parts. If you detect any damage, contact Enercare Home Services at 1-800-266-3939.
- 2) Verify that the type of gas being supplied corresponds to what is marked on the rating plate and gas control of the water heater.

Altitude

Input rating of this water heater is based on sea level operation. At higher elevations the actual input rate will be lower than the value listed on the rating plate due to the natural derating of natural gas. This water heater can be installed at elevation up to 5,400 feet (1,646 m) without any change of modification. Do not attempt to adjust the input rate by changing the manifold pressure.

⚠ WARNING

Failure to install a water heater suitable for the altitude at the location it is intended to serve, can result in improper operation of the appliance resulting in property damage and/or producing carbon monoxide gas, which could result in personal injury or death.

Location

This water heater should be located close enough to the outside wall so that it is within the venting requirements listed in these installation instructions and as close as possible to the main use of hot water. This location must not be subject to freezing temperatures. The water heater should be positioned, so that there is easy access to the burner, gas control and drain valve. It must be located close to a suitable free-flowing floor drain. Where a floor drain is not adjacent to the water heater, a suitable drain pan must be installed under the water heater (see **Figure 12**). In Canada, according to local codes, this drain pan should be at least two (2) inches (5.1 cm) larger than the diameter of the water heater and at least one (1) inch (2.5 cm) deep, providing access to the drain valve. Local codes may be more rigorous. This pan must not restrict the flow of ventilation and combustion air. This pan must be piped to a suitable drain to prevent damage to property in the event of a water leak from the piping, the relief valve, or the water heater.

Sooner or later, all water heaters leak. The manufacturer, based on national building codes, has given the necessary instructions to prevent damage to the building. Under no circumstances is the manufacturer to be held liable for any water damage in connection with this water heater.

This water heater is approved for installation on either a combustible or non-combustible floor. However, should this water heater be installed directly on carpeting, such carpeting must be protected by a wood or metal panel beneath the water heater. This panel must extend at least three (3) inches (7.6 cm) beyond the width and depth of the water heater. Should the water heater be installed in an alcove or closet, the entire floor area must be covered by the panel.

Minimum Clearances

The minimum clearances from combustible material for this water heater are: Two (2) inches (5.1 cm) from the sides and rear, four (4) inches (10.2 cm) from the front and ten (10) inches (25.4 cm) from the top (see **Figure 1**).

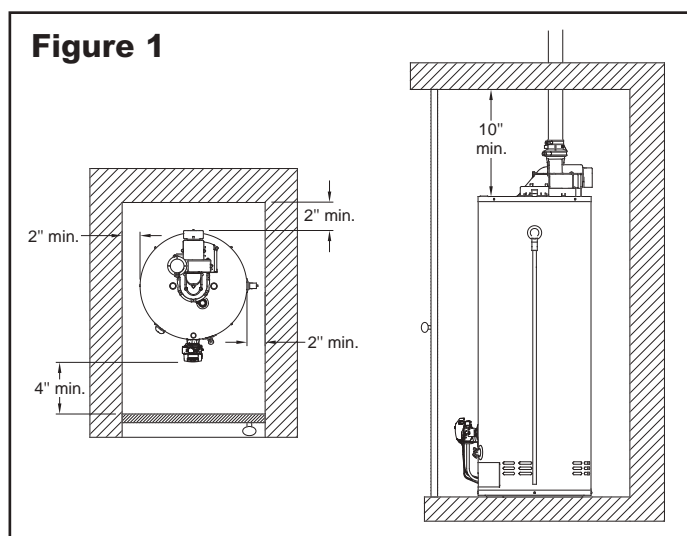

INSTALLATION INSTRUCTIONS

Combustion and Ventilation Air Supply

In order for the water heater to operate properly, it must be supplied with an uninterrupted flow of clean combustion and ventilation air. The area around the water heater must always be kept clear and the combustion air intake holes at the bottom of the water heater must never be blocked. An inadequate supply of air to the water heater will produce a bright yellow burner flame causing sooting in the combustion chamber, on the burner and in the flue tube. This can result in damage to the water heater and serious bodily injury, if not corrected.

Combustion and ventilation air requirements are determined by where the water heater will be located. Water heaters are installed in either open (unconfined) spaces or smaller (confined) spaces, such as closets or small rooms.

Requirements for Unconfined Spaces

An unconfined space is an area with at least fifty (50) cubic feet for each 1,000 Btuh (4.8 m³/kW) of the total input rating for all gas appliances installed in that space. Water heaters installed in unconfined spaces do not usually require outdoor air to function properly. However, in buildings with tight construction (heavy insulation, vapour barriers, weather stripping, etc.) and particularly in modern buildings, additional fresh air may need to be provided. For instructions on obtaining additional air supply, see the requirements below for confined spaces.

Requirements for Confined Spaces

A confined space is an area where the volume is less than fifty (50) cubic feet for each 1,000 Btuh (4.8 m³/kW) of the total input rating for all gas appliances installed in that space. Water heaters installed in confined spaces require additional air. This can be provided in two ways:

In Canada (refer to CSA B149.1)

1) All Air From Inside the Building (see Figure 2):

The confined space shall be provided with one (1) opening of one (1) square inch per 1,000 Btuh (22.0 cm²/kW) communicating directly with one or more rooms of sufficient volume, so that the combined volume of all spaces meets the criteria for an unconfined space for all the appliances installed in that confined space. A water heater of 50,000 Btuh or less could, in some cases, not require fresh air from outside. Please refer to the current CSA B149.1 code and local codes for further details

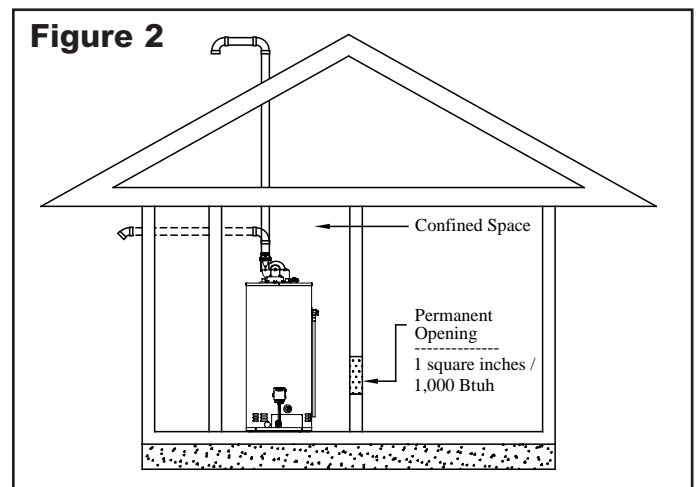

2) All Air From Outdoors: (see Figure 3):

An air supply shall be provided with one opening that communicates directly with the outdoors by means of a duct. This duct shall be sized according to CSA B149.1 and terminate within one (1) foot (30.5 cm) above and within two (2) feet (61 cm) horizontally from the burner level of the appliance having the largest input.

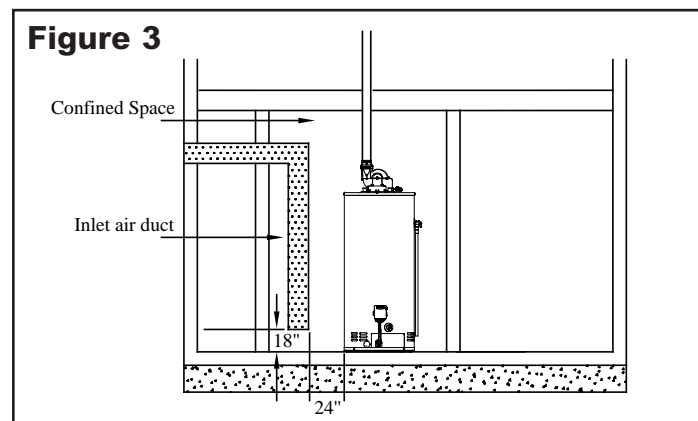

In U.S.A. (refer to ANSI Z223.1/NFPA 54)

1) All Air From Inside the Building (see Figure 4):

The confined space shall be provided with two permanent openings communicating directly with one or more rooms of sufficient volume, so that the combined volume of all spaces meets the criteria for an unconfined space. The total input rating of all gas appliances installed in the combined space shall be considered in making this determination.

Each opening shall have a minimum free area of one (1) square inch per 1,000 Btuh (22.0 cm²/kW) of the total input rating of all gas appliances in the confined space, **but not less than** one hundred (100) square inches (645.16 cm²). One opening shall commence within twelve (12) inches (30,5 cm) of the top and one within twelve (12) inches (30,5 cm) of the bottom of the enclosure.

INSTALLATION INSTRUCTIONS

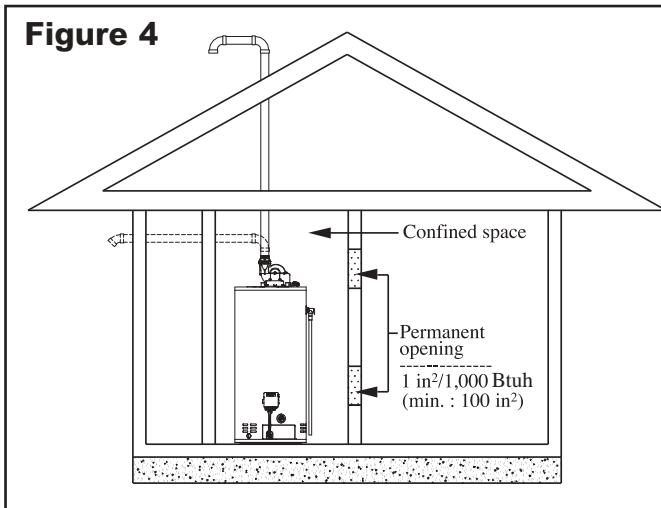

2) All Air From Outdoors:

The confined space shall be provided with two permanent openings, one commencing within twelve (12) inches (30,5 cm) of the top and one commencing within twelve (12) inches (30,5 cm) from the bottom of the enclosure. The openings shall communicate directly or by ducts, with the outdoors or spaces (crawl or attic) that freely communicate with the outdoors.

A) When communicating directly with the outdoors, each opening shall have a minimum free area of one (1) square inch per 4,000 Btuh (5.5 cm²/kW) of the total input rating of all gas appliances in the enclosure (**see Figure 5**).

B) When communicating with the outdoors through vertical ducts, each opening shall have a minimum free area of one (1) square inch per 4,000 Btuh (5.5 cm²/kW) of the total input rating of all gas appliances in the enclosure (**see Figure 6**).

C) When communicating with the outdoors through horizontal ducts, each opening shall have a minimum free area of one (1) square inch per 2,000 Btuh (11.0 cm²/ kW) of the total input rating of all gas appliances in the enclosure (**see Figure 7**).

When ducts are used, they shall be of the same cross-sectional area as the free area of the openings to which they connect. The minimum short side dimension of rectangular air ducts shall not be less than three (3) inches (7.6 cm).

Louvers and Grilles

In calculating free area for ventilation and combustion air supply openings, consideration must be given to the blocking effect of louvers, grilles, or screens protecting the openings. Screens must not be smaller than 1/4 inch (6.4 mm) mesh. If the free area through a particular design of louver or grille is known, it should be used in calculating the size of opening required to provide the free area specified. If the design and free area is not

known, it may be assumed that wood louvers and grilles will allow 20-25% free area and metal louvers and grilles will allow 60-75% free area. Louvers and grilles must be installed in the open position or interconnected with the water heater so that they are opened automatically during water heater operation (automatic mechanical louvers).

Corrosive Atmospheres

If this water heater is to be installed in a beauty shop, barber shop, photo processing lab, dry cleaning establishment, a building with an indoor pool, or near a chemical storage area, it is imperative that the combustion and ventilation air be drawn from outside these areas. These particular environments contain products such as aerosol sprays, detergents, bleaches, cleaning solvents, refrigerants, and other volatile compounds that, in addition to being highly flammable, become highly corrosive acid compounds when burned. Exposure to such compounds can be hazardous and lead to premature product failure.

Should the water heater fail, due to exposure to such a corrosive atmosphere, the warranty is void. Enercare Home Services may be entitled for compensation.

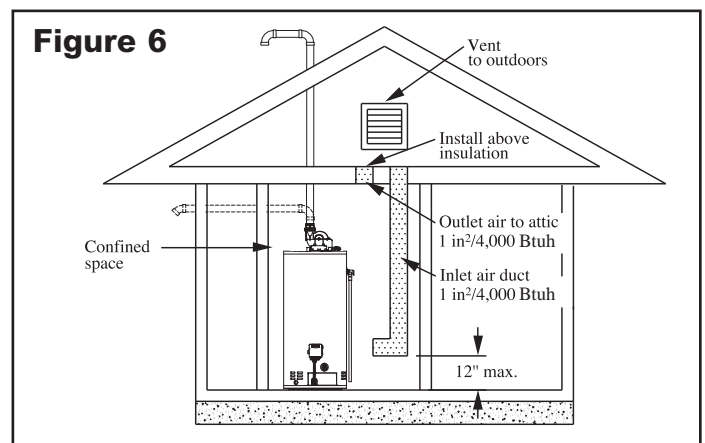
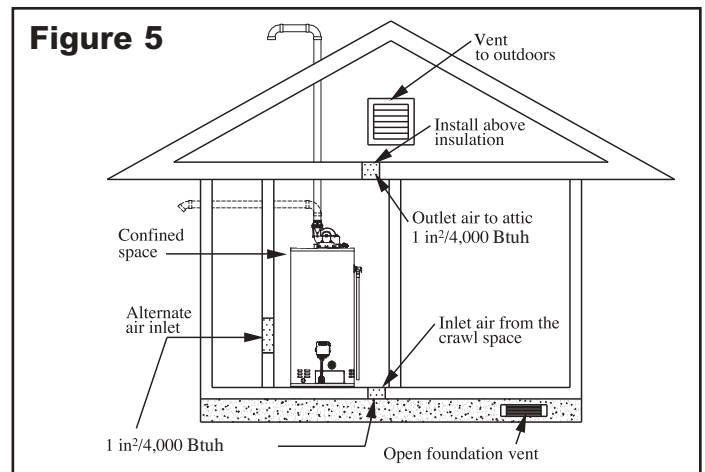

INSTALLATION INSTRUCTIONS

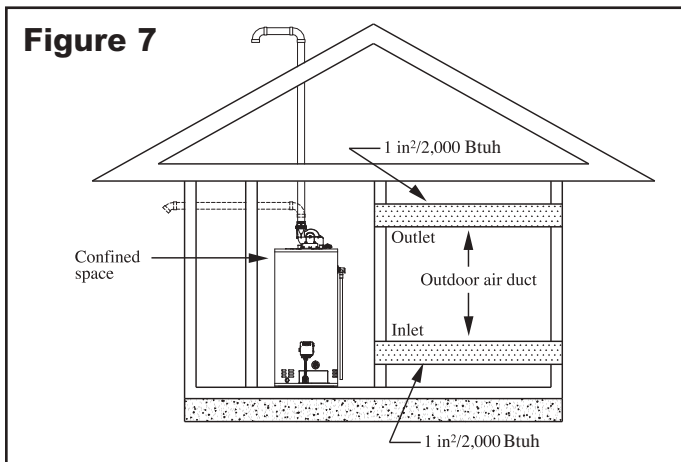

The water heaters covered in this manual are classified as category III appliances and can be vented using only one of the following options:

- Two (2) inch (5.1 cm) or three (3) inch (7.6 cm) schedule 40 PVC or CPVC pipe and fittings; **PVC** **CPVC**
- Two (2) inch (5.1 cm) or three (3) inch (7.6 cm) polypropylene rigid pipe and fittings from Centrotherm™ (InnoFlue® single wall vent system); **InnoFlue®** **Centrotherm™**
- Two (2) inch (5.1 cm) or three (3) inch (7.6 cm) polypropylene rigid pipe and fittings from DuraVent® (PolyPro® single wall gas vent system). **PolyPro®** **DuraVent®**

Venting

⚠ WARNING

When installing the venting system, make sure to follow all local codes or, in the absence of local codes, CSA B149.1, Natural Gas and Propane Gas Installation Code, in Canada and/or the National Fuel Gas Code, ANSI Z223.1/NFPA 54, in the United States. **NEVER** operate the water heater unless it is properly ventilated to the outdoors and has adequate air supply for proper operation. Failure to properly install the venting system could result in property damage, personal injury, or death.

Before installing the vent piping, make sure that the vent system layout has been properly planned. Verify that the location of the water heater respects all clearances from combustible material, all venting requirements (see **Table 1**) and that the vent terminal will be installed as specified by all local codes or, in the absence of local codes, CSA B149.1, Natural Gas and Propane Installation Code, in Canada and/or the National Fuel Gas Code, ANSI Z223.1/NFPA 54, in the United States (see **Figure 15**).

This water heater is equipped with a power venter that evacuates the products of combustion to the outdoors. All models are shipped from the factory with the power venter already installed.

IMPORTANT

According to the CSA B149.1, Natural Gas and Propane Installation Code, plastic vent systems installed in Canada must be certified to the STANDARD FOR TYPE BH GAS VENTING SYSTEMS, ULC S636. Components of the certified vent system must not be interchanged with other vent systems or unlisted pipe/fittings. Plastic components and specified primers and glues of the certified vent system must be from a single vent system manufacturer and not intermixed with other vent system manufacturer's vent system parts unless those are certified to be used with this system. Plastic vent systems shall also be installed such that the first three (3) feet (91 cm) of pipe from the water heater outlet are readily accessible for visual inspection.

This water heater must be vented directly to the outdoors, either horizontally through the wall or vertically through the roof. The venting must not be attached to an existing chimney or in common with any other appliance and must not be insulated.

Venting Connection to the Water Heater

PVC PIPE: **PVC**

A vent system adaptor should be installed when using PVC pipes for venting this water heater (see **Figure 9**). The vent system adaptor supplied with the water heater is made of IPEX parts. If another manufacturer of pipe is used to build the vent system, the vent system adaptor must be made from parts of that same manufacturer. To build the vent system adaptor, you will need a 2 3/8 inch (6 cm) piece of CPVC pipe and a two (2) inch (5.1 cm) PVC coupling glued together with the proper cement.

Table 1

MAXIMUM EQUIVALENT LENGTH OF VENT PIPE - DO NOT EXCEED MAXIMUM LENGTH		
PV2 Models only	UG40, UG50, and UG60	
VENT PIPE DIAMETER	2 inches (5.1 cm)	3 inches (7.6 cm)
Maximum equivalent length*	50.0 feet (15.2 m)	140.0 feet (42.7 m)
Minimum equivalent length*	7.5 feet (2.3 m)	9.5 feet (2.9 m)
One 45-degree elbow is equivalent, in straight pipe, to	3.0 feet (0.9 m)	4.0 feet (1.2 m)
One 90-degree elbow is equivalent, in straight pipe, to	5.0 feet (1.5 m)	7.0 feet (2.1 m)

* Note: Outdoor termination elbow not to be counted when determining total length.

INSTALLATION INSTRUCTIONS

Figure 8

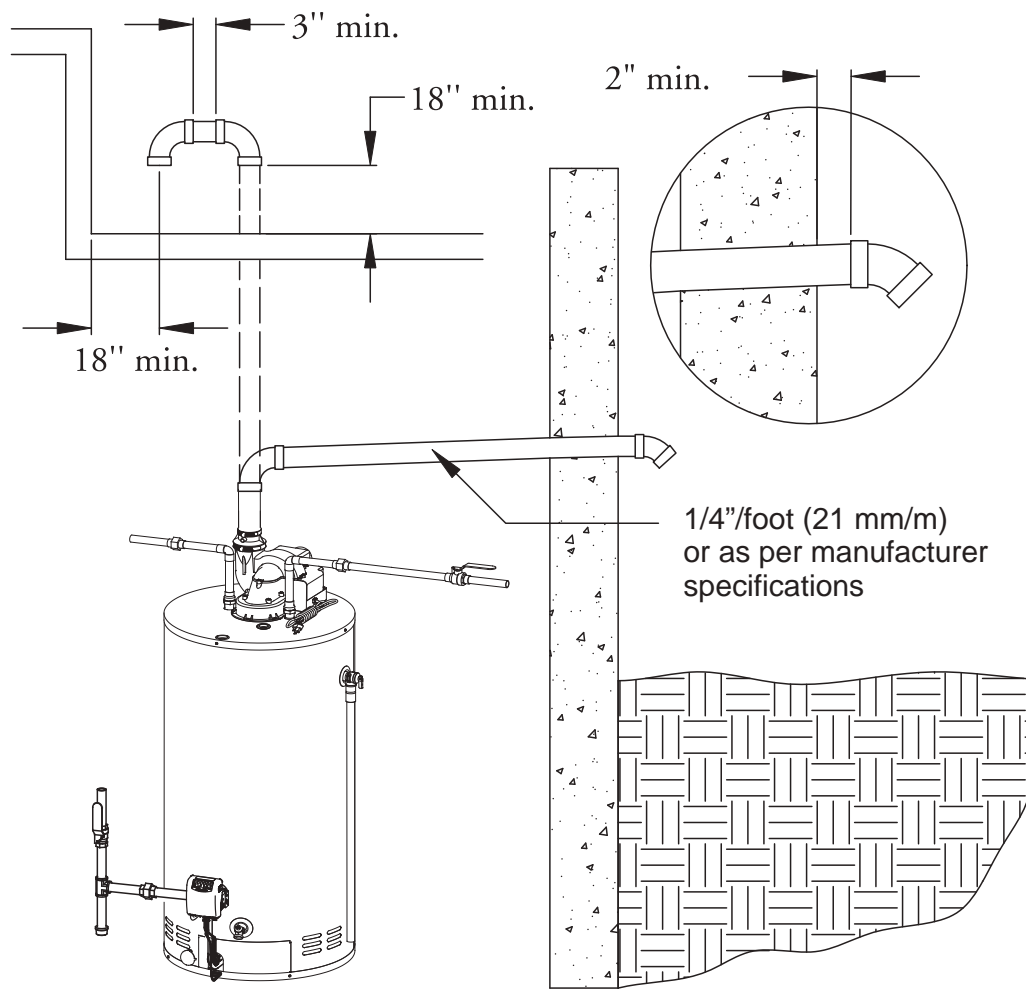
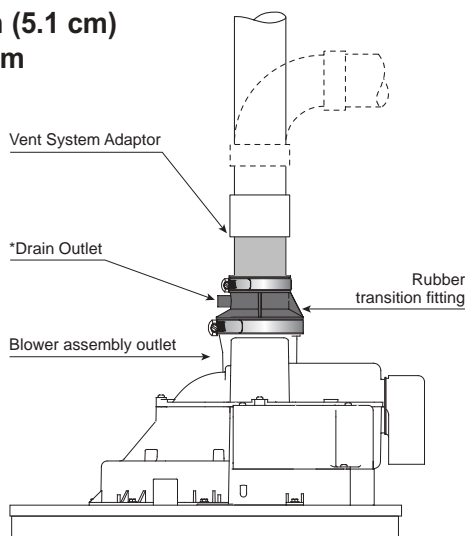
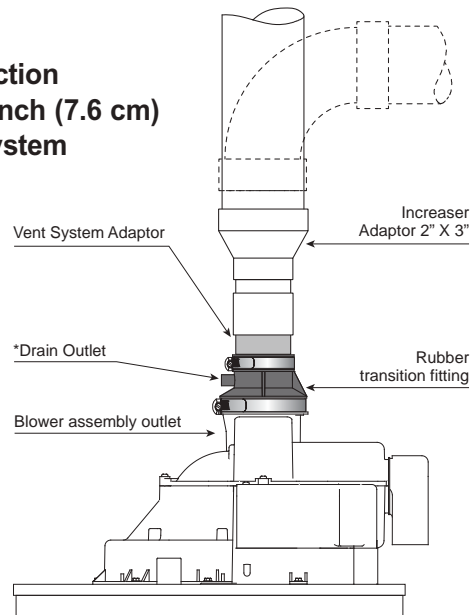

Figure 9

Connection to a 2-inch (5.1 cm) vent system



Connection to a 3-inch (7.6 cm) vent system



* A plastic tube can be attached to the drain outlet to evacuate any condensate. For more information, consult the owner's manual, section Condensation in the venting system.

The blower assembly must always have the two (2) inch (5.1 cm) rubber transition fitting. An increasing coupling 2" X 3" is necessary for a three (3) inch (7.6 cm) venting system. This coupling must be installed as close as possible after the rubber transition fitting and in every case, before the first elbow.

INSTALLATION INSTRUCTIONS

CPVC PIPE: **CPVC**

The CPVC pipe must be inserted directly into the rubber transition fitting on the outlet of the blower assembly.

Note: If your installation requires three (3) inch (7.6 cm) pipe, you must start with two (2) inch (5.1 cm) pipe and add a two (2) to three (3) inch (5.1 to 7.6 cm) increaser to change the size of the pipe to three (3) inches (7.6 cm) (see **Figure 9**).

CENTROTHERM™ POLYPROPYLENE PIPE

(InnoFlue® single wall vent system): **InnoFlue® Centrotherm™**

Use special appliance adapter from Centrotherm™ and insert into the rubber transition fitting on the outlet of the blower assembly. Refer to the **Table 2** and **Figure 10** below for proper part number from Centrotherm™. On the three (3) inch (7.6 cm) vent pipe, an increaser is necessary.

Table 2 — Centrotherm™

	Appliance adapter	Increaser
2-inch (5.1 cm) pipe	ISAA0202	N/A
3-inch (7.6 cm) pipe	ISAA0202	ISIA0203

DURAVENT® POLYPROPYLENE PIPE

(PolyPro® single wall gas vent system): **PolyPro® DuraVent®**

Use special appliance adapter from DuraVent® and insert into the vent system adaptor on the outlet of the blower assembly. Refer to the **Table 3** and **Figure 11** below for proper part number from DuraVent. On the three (3) inch (7.6 cm) vent pipe, an increaser is necessary. Make sure to use the appliance adapter clamp to connect the PolyPro® appliance adaptor to the vent system adaptor and to tighten both hose clamps on the appliance adapter clamp to ensure the connection is secure.

Table 3 — DuraVent®

	Appliance adapter	Increaser	Appliance adapter clamp
2-inch (5.1 cm) pipe	2PPS-AD	N/A	PPS-PAC
3-inch (7.6 cm) pipe	2PPS-AD	2PPS-X3	PPS-PAC

Through-the-Wall Venting Installation

Cut or drill a hole through the exterior wall, slightly larger than the diameter of the vent pipe selected. The larger hole will allow for final alignment with the water heater. Extend a section of the pipe through the hole to the outside and attach the terminating elbow to the exterior end of the pipe. Connect and secure all piping and elbows from the power venter to the wall. When the installation is completed, the vent terminal must be at two (2) inches (5.1 cm) from the exterior surface of the wall (see **Figure 8**). Make sure that all piping is properly braced. If the venting will pass through an enclosed area, make sure to leave at least one (1) inch (2.5 cm) clearance around the piping for air circulation.

PVC AND CPVC PIPES: **PVC CPVC**

Make sure that all horizontal runs have a minimum rise of 1/4 inch per foot (21 mm/m) of run (see **Figure 8**). Horizontal runs of vent pipe must be supported every three (3) feet (91 cm).

CENTROTHERM™ POLYPROPYLENE PIPE

(InnoFlue® single wall vent system): **InnoFlue® Centrotherm™**

Make sure that all horizontal runs have a minimum rise of 5/8 inch per foot (56 mm/m) of run. Follow instructions of the vent pipe manufacturer for proper vent support.

DURAVENT® POLYPROPYLENE PIPE

(PolyPro® single wall vent system): **PolyPro® DuraVent®**

Make sure that all horizontal runs have a minimum rise of 1/4 inch per foot (21 mm/m) of run. Follow instructions of the vent pipe manufacturer for proper vent support.

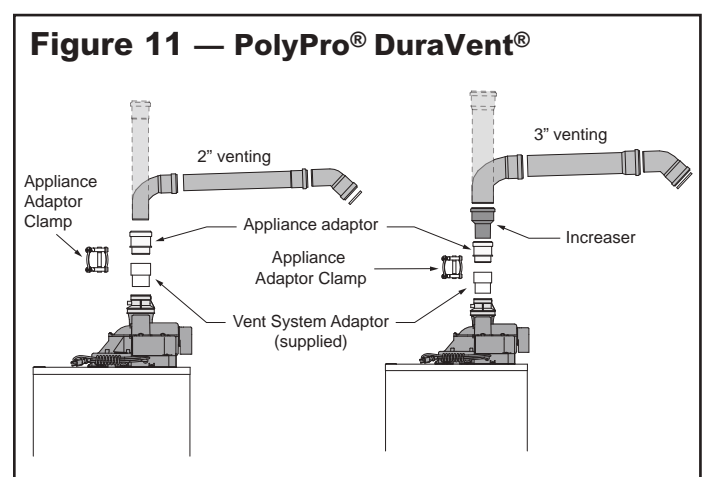
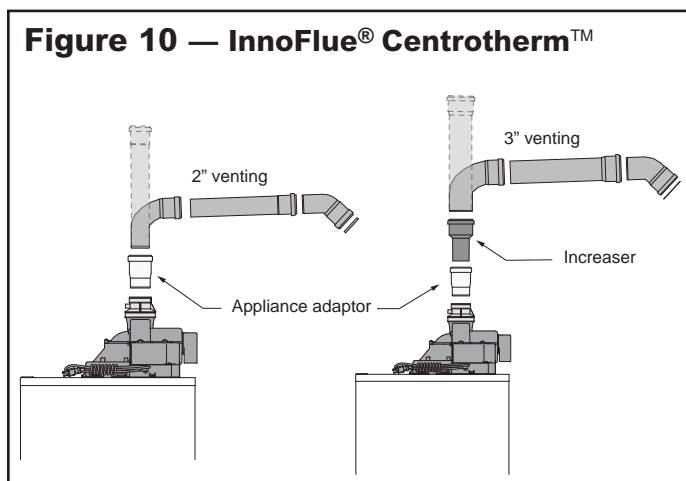

INSTALLATION INSTRUCTIONS

Through-the-Roof Venting Installation

Cut or drill a hole through the roof and ceiling, slightly larger than the diameter of the vent pipe selected. The larger hole will allow for the final alignment with the water heater. Construct the vent terminal assembly. Extend a section of pipe through the hole in the roof to the outside and attach the terminal assembly to the exterior end of the pipe. Connect and secure all piping and elbows from the power venter to the roof. When the installation is completed, the vent terminal must be a minimum of eighteen (18) inches (45.7 cm) from the exterior surface of the roof (**see Figure 8**). Make sure that all piping is properly braced. If the venting will pass through an enclosed area, make sure to leave at least one (1) inch (2.5 cm) clearance around the piping for air circulation.

PVC AND CPVC PIPES: **PVC** **CPVC**

Make sure that all horizontal runs have a minimum rise of 1/4 inch per foot (21 mm/m) of run (**see Figure 8**). Horizontal runs of vent pipe must be supported every three (3) feet (91 cm) and vertical runs of vent pipe must be supported every five (5) feet (1.5 m).

CENTROTHERM™ POLYPROPYLENE PIPE

(InnoFlue® single wall vent system): **InnoFlue® Centrotherm™**

Make sure that all horizontal runs have a minimum rise of 5/8 inch per foot (56 mm/m) of run. Follow instructions of the vent pipe manufacturer for proper vent support.

DURAVENT® POLYPROPYLENE PIPE

(PolyPro® single wall vent system): **PolyPro® DuraVent®**

Make sure that all horizontal runs have a minimum rise of 1/4 inch per foot (21 mm/m) of run. Follow instructions of the vent pipe manufacturer for proper vent support.

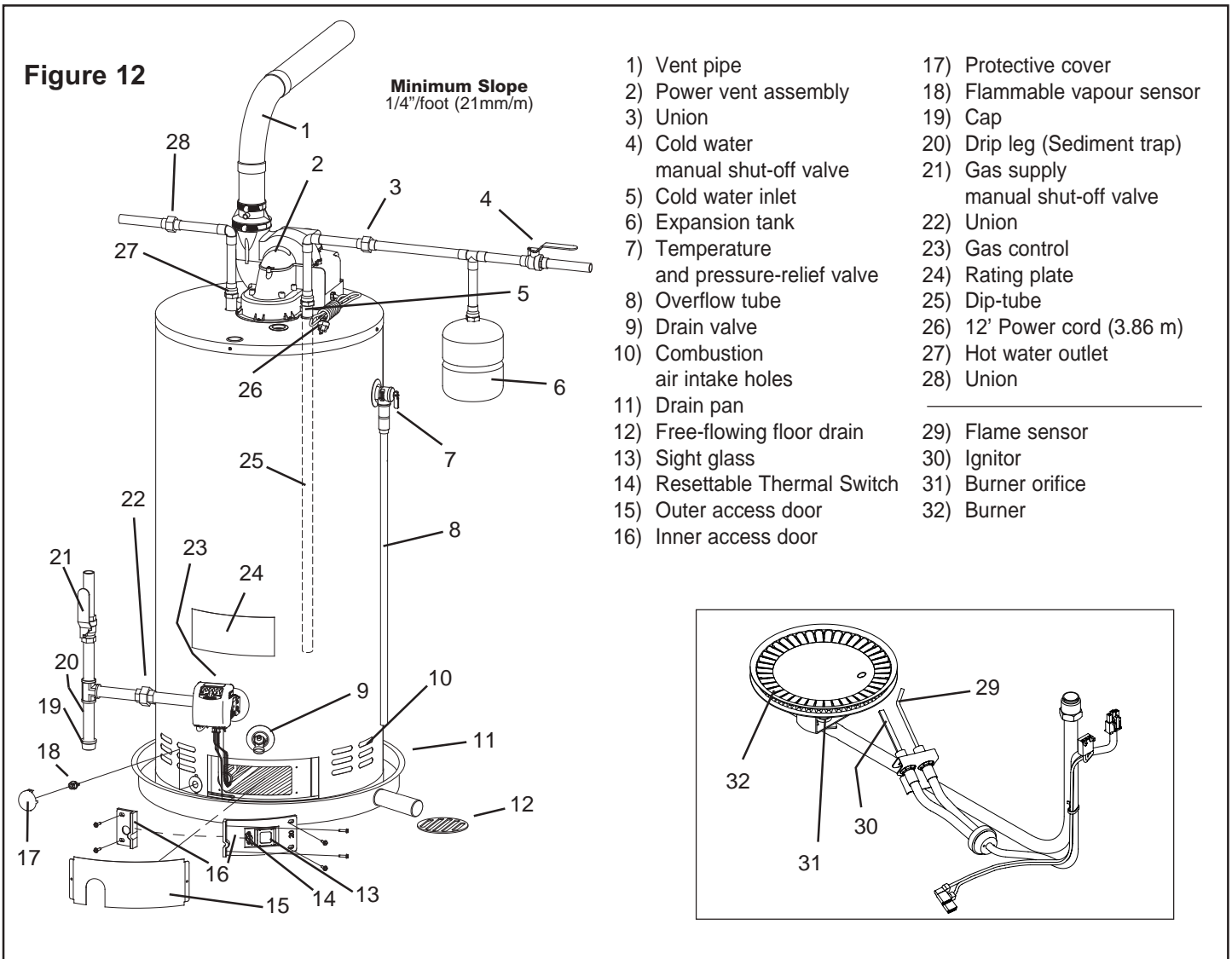

INSTALLATION INSTRUCTIONS

Pipe Assembly

⚠ WARNING

ALWAYS read and abide by all safety messages printed on the primer, cleaner, and cement containers. Primer, cleaner, and cements are extremely flammable. **DO NOT** store these products near heat, sparks, or flames. They are harmful or fatal if swallowed. Their vapours are also harmful. They may irritate eyes and can be absorbed through the skin. Failure to follow these instructions can result in property damage, personal injury, or death.

PVC AND CPVC VENT SYSTEM: **PVC** **CPVC**

Primers, cleaners, solvents, and cements are available for PVC and CPVC pipe/fittings. When cementing the pipe/fittings, make sure to use only materials approved for the type of pipe/fittings to be installed and in all cases, follow the vent pipe/fittings manufacturers joining instructions. Never use all-purpose cements, commercial glues, and adhesives to join PVC or CPVC pipe/fittings.

- 1) Adjust the vent pipe length to properly fit the vent system adaptor on the blower assembly outlet.
- 2) Cut pipe ends squarely, removing all burrs and dirt.
- 3) Dry fit the pipe/fitting to be connected to make sure they fit properly.
- 4) Clean the pipe/fitting with the proper primer or cleaner.
- 5) Apply a thin coat of cement to the fitting, avoiding puddling inside.
- 6) Apply a liberal coat of cement to the vent pipe, leaving no voids.
- 7) **QUICKLY** assemble parts while cement is fluid! If you wait too long, re-coat pipe/fitting.
- 8) Push the vent pipe completely into the coupling, turning as it goes until it bottoms out.
- 9) Hold pipe and fitting together for thirty (30) seconds. Then carefully clean off any excess material with a cloth. Allow connections a sufficient time to cure before disturbing.
- 10) Loosen the upper hose clamp on the rubber transition fitting and fully insert the CPVC pipe of the vent system adaptor (one (1) inch [2.5 cm] deep). Do not apply cement to the rubber transition fitting.
- 11) Tighten the upper hose clamp to ensure the vent pipe is firmly secured and gas tight.
- 12) Make sure that the lower hose clamp is firmly seated, secured and gas tight. Gently move the vent pipe side to side and vertically to ensure that it is securely in place and that there is no slippage.

POLYPROPYLENE PIPE: **PolyPro** **DuraVent** **InnoFlue** **Centrotherm**[™]
Follow the vent pipe manufacturer installation instructions to assemble the vent pipe. Make sure to secure the vent pipe sections together using the mean (connector ring or locking band) as specified by the vent pipe manufacturer.

Vent Termination Through-The-Wall

PVC AND CPVC VENT SYSTEM: **PVC** **CPVC**

A 45-degree PVC elbow is supplied with the water heater and shall be used as the termination elbow for through-the-wall installation when the vent system is built with PVC pipes. If CPVC is used to build the vent system, use a 45-degree CPVC elbow that is approved to be used with the vent system. A wire mesh screen must be installed in the termination elbow.

POLYPROPYLENE VENT SYSTEM:

PolyPro **DuraVent** **InnoFlue** **Centrotherm**[™]

A 45-degree Polypropylene elbow, approved to be used with the vent system shall be used as the termination elbow for through-the-wall installation. Be sure to remove the wire mesh screen that was supplied with the 45-degree PVC elbow and insert it into the polypropylene elbow. Push the screen until it locks in place inside the elbow.

VENT RISER

When venting cannot exit through the wall at height greater than or equal to twelve (12) inches (30.5 cm) above ground level, or anticipated snow level, the installation must be modified to include a vent riser as shown in the **Figure 13**. The maximum equivalent length of vent pipe (including the vent riser) must be in accordance with the specifications in the installation manual.

When a vent riser is necessary, it may produce excessive condensation in the vent system, so consideration must be taken to slope the vent piping (down) toward the water heater to prevent condensate water from collecting in any part of the vent system. Refer to the **Condensation in the Venting System** section in the installation manual.

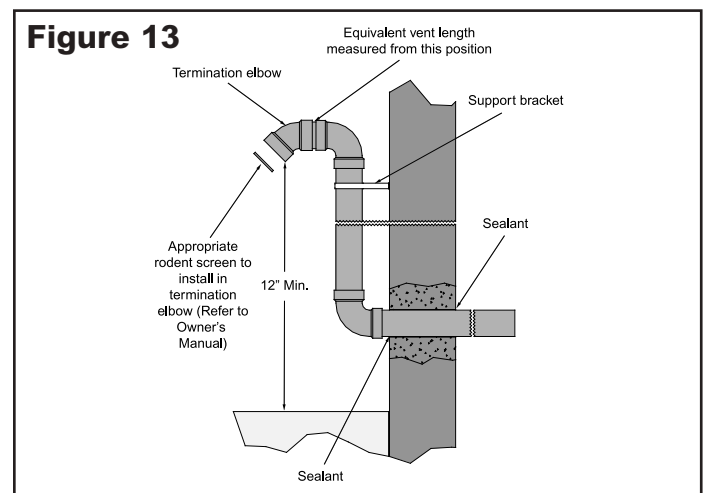

INSTALLATION INSTRUCTIONS

Vent Termination Through-The-Roof

PVC AND CPVC VENT SYSTEM: **PVC CPVC**

A 90-degree elbow (not supplied) shall be used as the termination elbow for Through-the-Roof installation (see Figure 8). Use a 90-degree elbow that is made of the same material as the vent system and approved to be used with this vent system. Be sure to remove the wire mesh screen that was supplied with the 45-degree PVC elbow and insert it into the 90-degree elbow. Push the screen until it locks in place inside the elbow.

POLYPROPYLENE VENT SYSTEM:

PolyPro® DuraVent® InnoFlue® Centrotherm™

A 90-degree Polypropylene elbow, approved to be used with the vent system shall be used as the termination elbow for through-the-roof installation. Be sure to remove the wire mesh screen that was supplied with the 45-degree PVC elbow and insert it into the polypropylene elbow. Push the screen until it locks in place inside the elbow.

⚠ WARNING

Check that all openings and gaps in the outside wall or roof near and around where the vent pipe passes through the exterior wall are sealed to prevent infiltration of combustion products into the building.

⚠ WARNING

In freezing weather, check for snow accumulation around the water heater vent terminal where it passes through the outside wall or roof. The open end of the terminal must be installed at least twelve (12) inches (30.5 cm) above the highest anticipated snowfall to prevent blockage by snow.

Restrictor Screens

A restrictor screen (see Figure 14) is provided with the following models (see Table 4).

Figure 14

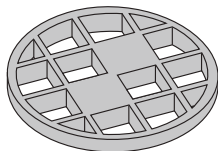



Table 4

Natural Gas	
UG40-40LFPV2-N2U-EC	
UG50-40LFPV2-N2U-EC	
UG60-40MFPV2-N2U-EC	

PVC AND CPVC VENT SYSTEM: **PVC CPVC**

A black restrictor screen (see Figure 14) is provided with the following models (see Table 4). When the total equivalent vent length is thirty (30) feet (9.1 m) or less of two (2) inch (5.1 cm) vent pipe, the wire mesh screen shall be removed from the vent termination elbow and the two (2) inch (5.1 cm) restrictor screen must be installed and glued. Otherwise, a standard wire mesh screen shall be installed. When using a three (3) inch (7.6 cm) vent pipe, a standard wire mesh (supplied with the water heater) must be installed in all cases (see Table 5).

POLYPROPYLENE VENT SYSTEM:

PolyPro® DuraVent® InnoFlue® Centrotherm™

A grey restrictor screen (see Figure 14) is provided with the following models (see Table 4). When the total equivalent vent length is thirty (30) feet (9.1 m) or less of two (2) inch (5.1 cm) vent pipe, the two (2) inch (5.1 cm) restrictor screen must be installed. Otherwise, a standard wire mesh screen shall be installed. To install the restrictor screen, remove the gasket at the end of the termination elbow and insert the restrictor screen. Push firmly the screen into the elbow pass the gasket groove. Put the gasket back into place. When using a three (3) inch (7.6 cm) vent pipe, a standard wire mesh (supplied with the water heater) must be installed in all cases (see Table 5).

⚠ DANGER

When the installation is complete, visually inspect the venting system to make sure that all joints are properly connected and all instructions have been followed. Failure to properly install the venting system could result in property damage, personal injury, or death.

Table 5

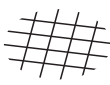
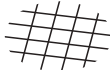
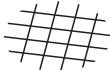
VENT DIAMETER	TERMINATION	0' - 30' (0 - 9.1 m)	30' - 50' (9.1 - 15.2 m)
2" (5.1 cm)	45-DEGREE ELBOW		
VENT DIAMETER	TERMINATION	0' - 30' (0 - 9.1 m)	30' - 140' (9.1 - 42.7 m)
3" (7.6 cm)	45-DEGREE ELBOW		

INSTALLATION INSTRUCTIONS

Figure 15

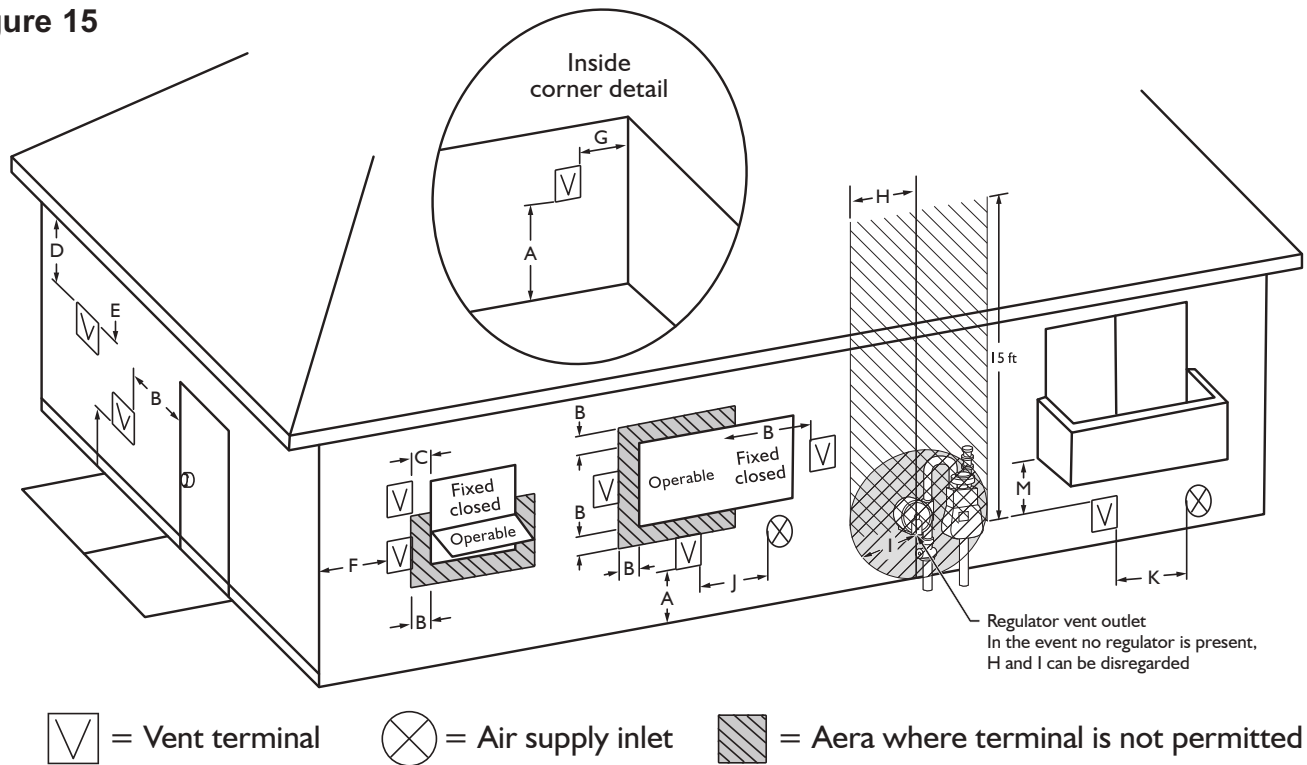

The Vent Termination must have a:

	Installations (Canada)¹	Installations (U.S.)²
A) Clearance above grade, veranda, porch, deck, or balcony.	12 inches (30 cm)	12 inches (30 cm)
B) Clearance to windows or doors that may be opened.	12 inches (30 cm) for appliances > 10,000 Btuh (3 kW) and ≤ 100,000 Btuh (30 kW), 36 inches (91 cm) for appliances > 100,000 Btuh (30 kW).	4 feet (1.2 m) below or to side of opening; 1 foot (300 mm) above opening.
C) Clearance to permanently closed windows.	*	*
D) Vertical clearance to ventilated soffit located above the terminal within a horizontal distance of 2 feet (61 cm) from the center line of the terminal.	*	*
E) Clearance to unventilated soffit.	*	*
F) Clearance to outside corner.	*	*
G) Clearance to inside corner.	*	*
H) Clearance to each side of center line extended above meter/regulator assembly.	3 feet (91 cm) within a height of 15 feet (4.6 m).	*
I) Clearance to regulator vent outlet.	3 feet (91 cm)	*
J) Clearance to non-mechanical air supply inlet to building or the combustion air inlet to any other appliance.	12 inches (30 cm) for appliances > 10,000 Btuh (3 kW) and ≤ 100,000 Btuh (30 kW), 36 inches (91 cm) for appliances > 100,000 Btuh (30 kW).	4 feet (1.2 m) below or to side of opening; 1 foot (300 mm) above opening.
K) Clearance to a mechanical air supply inlet.	6 feet (1.83 m)	3 feet (91 cm) above if within 10 feet (3 m) horizontally.
L) Clearance above paved sidewalk or paved driveway located on public property.	7 feet (2.13 m) [†]	7 feet (2.13 m)*
M) Clearance under veranda, porch, deck, or balcony.	12 inches (30 cm) [‡]	*

Notes:

1) In accordance with the current CSA B149.1, Natural Gas and Propane Installation Code.

2) In accordance with the current ANSI Z223.1/NFPA 54, National Fuel Gas Code.

* Clearance in accordance with local installation codes and the requirements of the gas supplier.

† A vent shall not terminate where it may cause hazardous frost or ice accumulation on adjacent property surfaces.

‡ Permitted only if veranda, porch, deck, or balcony is fully open on a minimum of two (2) sides beneath the floor.

INSTALLATION INSTRUCTIONS

Condensation in the Venting System

In some installations, condensation will form in the horizontal runs of vent piping. In order to effectively control the condensate from adversely affecting the mechanical components of the water heater (draining back into the blower), a rubber transition fitting with a drain outlet is mounted directly on the blower vent outlet.

Note: When the installation requires it, proceed with the following steps otherwise, make sure that the removable cap on the drain outlet is securely in place.

- Remove the cap on the drain outlet.
- Connect a clear, flexible, PVC tube with an inside diameter of 1/2 inch, or an equivalent material to the drain outlet. The drain tube must be of sufficient length to reach a suitable free-flowing drain or other required condensate disposal termination requirements (Refer to local codes).
- Loop the drain tube so that it has a circular trap (approximately eight (8) inches (20.3 cm) in diameter) and secure the top and bottom with zip ties as shown in **Figure 16**.
- Fill the drain tube with water (at least halfway) so that no combustion gases might vent into the room.
- Route the drain tube to the floor drain and secure the tube in a vertical position to the side of the water heater.

Figure 16

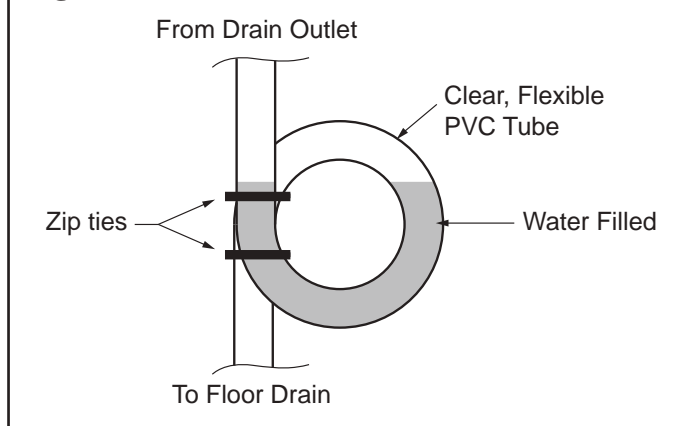

Water Piping

Refer to **Figure 12** for a typical installation. Use of this layout should provide a trouble-free installation for the life of the water heater. Before making the plumbing connections, locate the **COLD** water inlet and the **HOT** water outlet. These fittings are both 3/4" NPT male thread. Make sure that the dip tube is installed in the cold water inlet. Install a shut-off valve close to the water heater in the cold water line. It is recommended that unions be installed in the cold and hot water lines so that the water heater can be easily disconnected, if servicing is required.

When assembling the hot and cold piping to the water heater, use Teflon™ tape or a good food grade of pipe joint compound, and ensure all fittings are tight. **DO NOT APPLY HEAT TO THESE FITTINGS** when making sweat connections to the water heater. Sweat (solder) tubing to threaded adaptors before connecting to the water heater. **IT IS IMPERATIVE THAT NO HEAT BE APPLIED** to the cold water inlet, as it contains a non-metallic dip-tube. **This will result in premature failure of the fittings, which is not covered by the warranty.**

Temperature and Pressure-Relief Valve

▲ WARNING

DO NOT plug the temperature and pressure-relief valve or its discharge line. **DO NOT** remove the relief valve. Make sure the relief valve is properly sized for the water heater. If the relief valve continuously discharges water, contact Enercare Home Services at 1-800-266-3939. Failure to follow these instructions can result in property damage, personal injury, or death.

To protect from excessive pressure and/or temperature, the manufacturer has installed a temperature and pressure-relief valve that meets the requirements of the Standard for Relief Valves and Automatic Gas Shut-Off Devices for Hot Water Supply Systems, CSA 4.4, in Canada and ANSI Z21.22, in the United States. This relief valve has a maximum set pressure that does not exceed the hydrostatic working pressure of the water heater (150 psi = 1,035 kPa) and a Btuh rating equal to or greater than the input rating, as shown on the water heater rating plate. It should never be plugged or removed from the opening marked for it on the water heater.

Should this relief valve need to be replaced, use only a new temperature and pressure-relief valve. **NEVER** install an old or existing relief valve, as it may be damaged or inadequate for the working requirements of the new water heater. This new relief valve must meet all local codes or, at a minimum, the requirements listed above. **NEVER** install any other type of valve between the relief valve and the water heater.

A discharge line must be installed into the relief valve. The discharge line:

- Must not be smaller than the outlet pipe size of the relief valve.
- Must not terminate less than six (6) inches (15.2 cm) and not more than twelve (12) inches (30.5 cm) above the floor.
- Must not be restricted in any way. Do not thread, cap, or in any way restrict the end of this outlet.

INSTALLATION INSTRUCTIONS

- Must be of a material capable of withstanding 210°F (99°C) without distortion.
- Must be installed to allow complete drainage of the relief valve and discharge line.
- Must terminate at an adequate free-flowing drain.

Pressure Build-up in a Water System

When the water heater operates, the heated water expands creating a pressure build-up. This is a natural function and is one of the reasons for installing a temperature and pressure-relief valve. If the cold water supply line has a built-in water meter, check valve, or pressure-reducing valve, a suitable expansion tank must be installed to prevent pressure build-up or water hammer effect. Otherwise, the warranty is void (**see Figure 12**). An indication of pressure build-up is frequent discharges of water from the relief valve. If the relief valve discharges water on a continuous basis, it may indicate a malfunction of the relief valve. Call Enercare Home Services at 1-800-266-3939. If the relief valve is not defective, the service call may be at the cost of the consumer.

Filling the Water Heater

⚠ WARNING

NEVER operate the water heater unless it is completely filled with water. **Failure to follow this instruction can result in premature failure of the water heater that is not covered by the warranty.**

Check that all of the water piping connections have been made. To fill the water heater:

- 1) Make sure that the water heater drain valve is closed by inserting a flat-head screwdriver into the slot on the head of the drain valve and turning the knob clockwise .
- 2) Open the cold water supply manual shut-off valve. This valve must remain open, as long as the water heater is in use. **NEVER** operate the water heater with the cold water supply manual shut-off valve closed.
- 3) To make sure the water heater is completely full of water, open all of the hot water faucets in the house to let the air out of the water heater and plumbing system. Leave the faucets open until a constant flow of water is obtained.
- 4) Check all of the plumbing connections to make sure there are no leaks.

Gas Connections

⚠ WARNING

DO NOT attempt to use this water heater with any gas other than the type of gas shown on the water heater rating plate. Failure to follow this instruction can result in property damage, personal injury, or death.

The gas piping must be installed as indicated in **Figure 12**. For the correct size of piping for this water heater, consult CSA B149.1, National Gas and Propane Installation Codes (in Canada) and/or the National Fuel Gas Code, ANSI Z223.1/NFPA 54, in the United States. Only new piping with cleanly cut threads may be used, together with a suitable sealing compound that is approved for natural and propane gases. It is mandatory that a readily accessible manual shut-off valve be installed in the gas supply line. The gas supply manual shut-off valve must be close to the water heater. A drip leg (sediment trap) must be installed in the gas line ahead of the gas control to prevent dirt from entering it. A union must be installed between the gas control and the gas supply manual shut-off valve for easy maintenance of the water heater.

⚠ WARNING

NEVER use an open flame to test for gas leaks. A fire or explosion could occur resulting in property damage, personal injury, or death.

The water heater and its gas connection must be leak tested before placing the appliance into operation. To leak test the system:

- 1) Turn on the manual gas shut-off valve near the water heater.
- 2) Use a soapy water solution to test all connections and fittings for leaks. Bubbles indicate a gas leak.
- 3) Correct all leaks.

Make sure that the inlet pressure to the water heater does not exceed 1/2 psi (3.5 kPa) for both natural and propane gases. Pressures in excess of 1/2 psi (3.5 kPa) can damage the gas control, resulting in a fire or explosion from leaking gas. For purposes of adjustment, the minimum inlet pressure should be one (1) inch (2.5 cm) water column above the operating manifold pressure. If manifold pressure is tested at the outlet pressure tap of the gas control, results should show 4" w.c. + 0,3" w.c..

INSTALLATION INSTRUCTIONS

If any pressure testing of the gas line is undertaken at test pressures in excess of 1/2 psi (3.5 kPa), the water heater and its gas supply manual shut-off valve must be disconnected from the gas supply piping system and the end of the pipe sealed with a female cap. If the testing is to be undertaken at a test pressure less than 1/2 psi (3.5 kPa), the gas supply manual shut-off valve must be closed. All testing must be done according to CSA 149.1 in Canada and/or the National Fuel Gas Code, ANSI Z223.1 in the United States and local codes.

⚠ WARNING

U.L. and CSA recognized fuel gas and Carbon Monoxide (CO) detectors are recommended in all applications and should be installed using the manufacturer's instructions and local codes, rules or regulations.

Installation Instructions for Water Heaters Approved for Space Heating and Potable Water Heating (see Figure 17)

A water heater cannot be used for space heating application only. When using a water heater for space and potable water heating, the instructions provided in this manual and with the air-handling unit must be respected and, **in particular**, the following:

- 1) All piping and components that are used in the system must be of a nonferrous type suitable for potable water. This also applies to any sealant used.
- 2) When used as a dual purpose water heater, it must not be connected to any system that has been previously used for non-potable water heating. This includes any piping because, in all probability, existing piping would have been, in the past, treated with chemicals for cleaning or sealing the system.
- 3) If this water heater is to be used for space heating, make sure that all safety codes are respected. Pay special attention to safety valve pressure and expansion tanks.
- 4) Do not use toxic chemicals to clean the potable water heating system.
- 5) Where water temperature in excess of 140°F (60°C) is required for a space heating application, a mixing valve must be installed in the potable side of the system. This will temper the water and reduce the risk of scalding.

6) If the incoming water line to the heater is equipped with a check valve, water meter, or pressure-reducing valve, an expansion tank must be installed in the system. This will prevent weeping from the water heater relief valve and premature failure of the heater due to expansion of the water during the heating cycle.

7) Before acquisition of a water heater for space heating application, it is necessary to have the area of intended use sized by Enercare Home Services. This will ensure that an adequate water heating capacity will be available for both heating and potable water supply and that the application will meet all local codes and public utility requirements.

Note: It is good practice to oversize the water heater, to ensure that all of the potential hot water requirements are available.

Wiring

⚠ WARNING

This water heater uses an external electrical source for power. It must be electrically grounded in accordance with all local codes or, in the absence of local codes, CAN/CSA C22.1 Canadian Electrical Code, in Canada and/or the National Electrical Code, ANSI/NFPA 70, in the United States. Failure to properly ground this water heater can result in property damage, personal injury, or death.

Before lighting your water heater, check that all of the wires have been installed correctly (**see Figure 18**). Make sure that none of the wires are grounded, have split, or are broken. Verify that all wiring connections are properly secured, as there is a possibility that they have become loose during transportation. If any of the original wiring needs replacing, use only 18AWG-type or greater wire that is approved for 221°F (105°C).

INSTALLATION INSTRUCTIONS

Figure 17

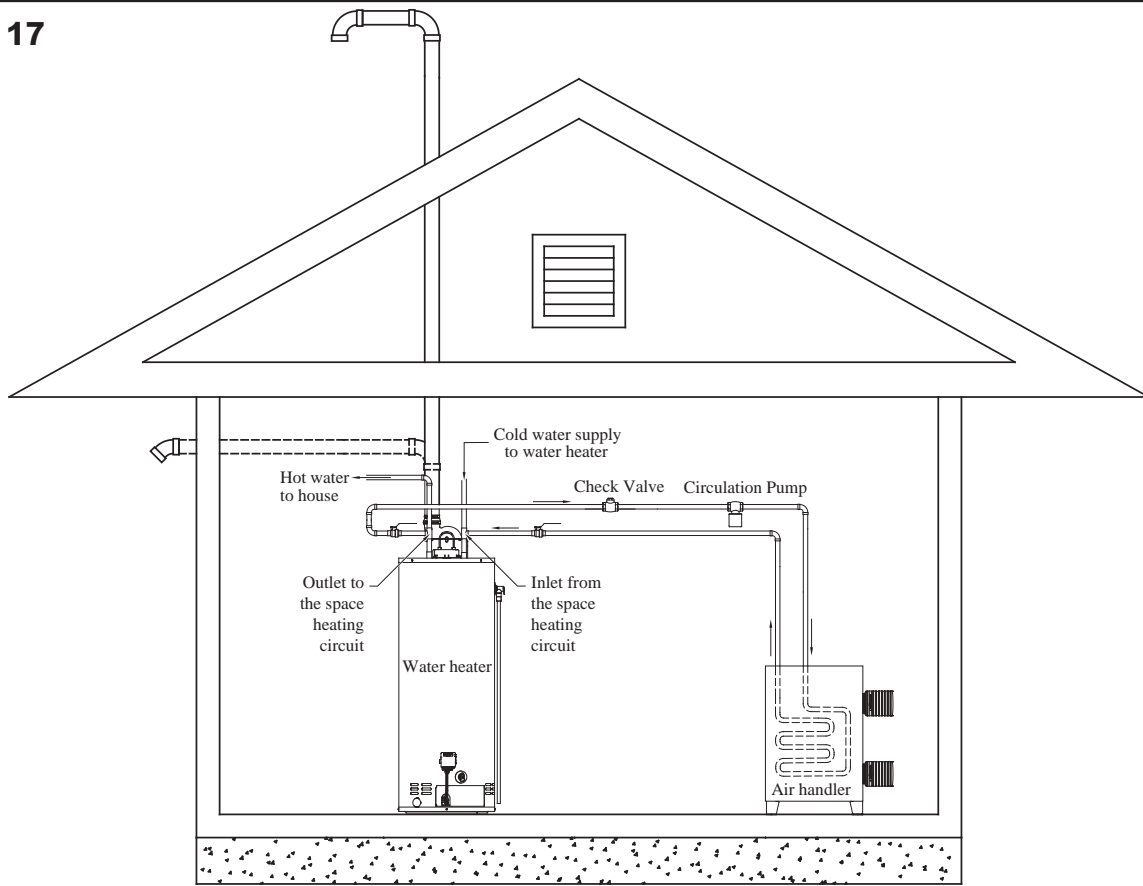

Wiring Diagram

Figure 18

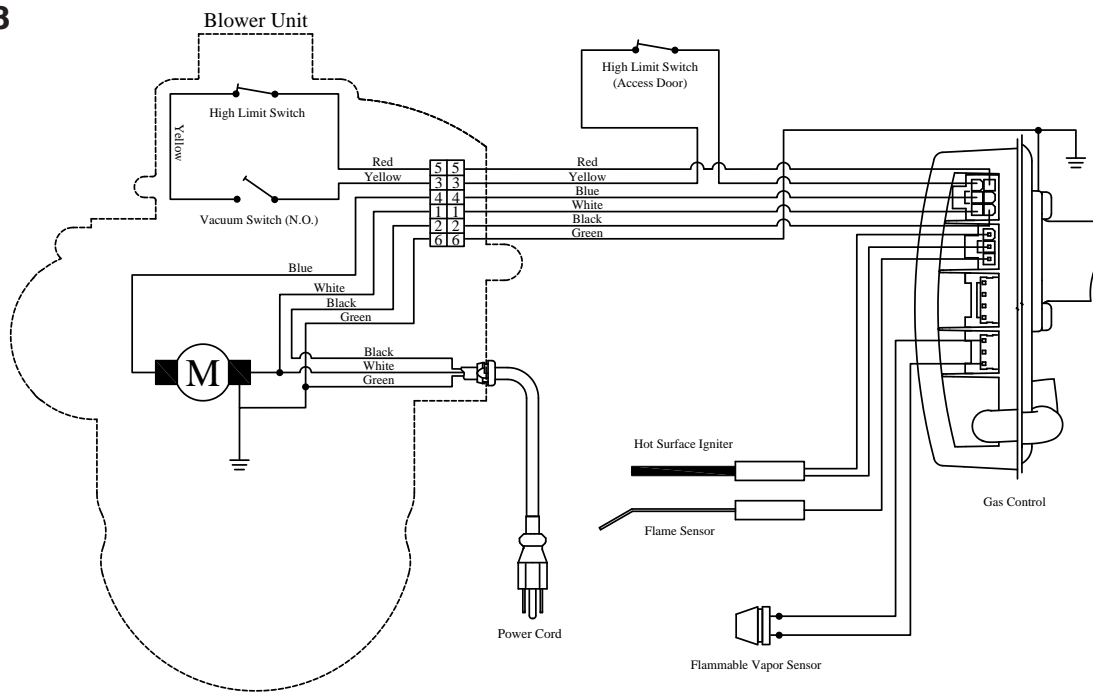

Installation Checklist

Refer to the Enercare Home Services checklist

OPERATING INSTRUCTIONS

Operating the Water Heater



Lighting or re-lighting your water heater will be done by Enercare Home Services. For any problems occurring after installation please contact: Enercare Home Services at 1-800-266-3939.

▲ WARNING

DO NOT operate this water heater if:

- It is not full of water.
- The gas supplied does not match the type listed on the rating plate.
- Gasoline or other flammable vapours and liquids have been stored in the vicinity of the water heater.

Failure to follow these instructions can result in property damage, personal injury, or death.

Operating Instructions

FOR YOUR SAFETY READ BEFORE OPERATING

WARNING: If you do not follow these instructions exactly, a fire or explosion may result causing property damage, personal injury, or loss of life.

- A.** This appliance does not have a pilot. It is equipped with an ignition device which automatically lights the burner. **DO NOT** try to light the burner by hand.
- B. BEFORE OPERATING** - Smell all around the appliance area for gas. Be sure to smell next to the floor because some gas is heavier than air and will settle on the floor.

WHAT TO DO IF YOU SMELL GAS:

- **DO NOT** try to light any appliance.
- **DO NOT** touch any electric switch.
- **DO NOT** use any phone in your building.
- Immediately call your gas supplier from a neighbor's phone. Follow the gas supplier's instructions.

- If you cannot reach your gas supplier, call the fire department.
- C.** Use only your hand to push in the gas control buttons. Never use tools. If control buttons will not push in, don't try to repair them, call Enercare Home Services at 1-800-266-3939. Force or attempted repair may result in a fire or explosion.
- D.** Do not use this appliance if any part has been under water. Immediately call Enercare Home Services at 1-800-266-3939 to inspect the water heater and to determine an action plan. Do not attempt to repair the unit!

OPERATING INSTRUCTIONS

1. **STOP!** Read the safety information above on this label.
2. Toggle the "ON/OFF" switch located on the gas control to the "ON" position.
3. Set the thermostat to the lowest setting by pressing the COOLER (◀) and HOTTER (▶) buttons at the same time and holding them for one (1) second. Then press the COOLER (◀) button until only the VAC indicator light is lit.
4. Toggle the "ON/OFF" switch located on the gas control to the "OFF" position.

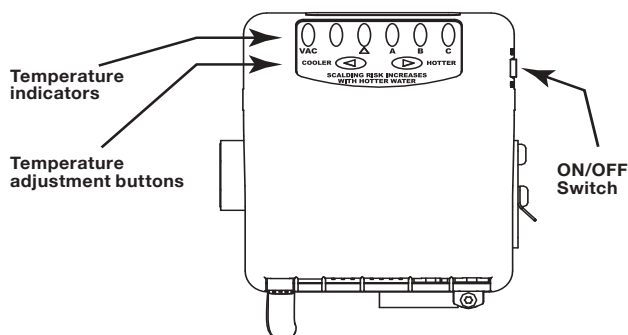

5. Turn off all electrical power to the appliance.
6. This appliance is equipped with an ignition device which automatically lights the burner. **DO NOT** try to light the burner by hand.
7. Wait five (5) minutes to clear out any gas. Then smell for gas, including near the floor. If you smell gas, **STOP!** Follow step "B" in the safety information above on this label. If you do not smell gas, go to the next step.
8. Turn on all electrical power to the appliance.
9. Toggle the "ON/OFF" switch located on the gas control to the "ON" position.
10. Set thermostat to the desired temperature setting by pressing the COOLER (◀) and HOTTER (▶) buttons at the same time and holding them for one (1) second. Then press the HOTTER (▶) button until the desired temperature display setting is lit. The preferred starting point for temperature setting is indicated by ▲ on the temperature indicators.
11. If the appliance will not operate, follow the instructions "TO TURN OFF GAS TO APPLIANCE" and call immediately Enercare Home Services at 1-800-266-3939.

TO TURN OFF GAS TO APPLIANCE

1. Set the thermostat to the lowest setting by first pressing the COOLER (◀) and HOTTER (▶) buttons at the same time and holding for one (1) second. Then press the COOLER (◀) button until only the VAC indicator light is lit.
2. Toggle the "ON/OFF" switch located on the gas control to the "OFF" position.
3. Turn off all electrical power to the appliance if service is to be performed.

OPERATING INSTRUCTIONS

Water Temperature Regulation

⚠ WARNING

The higher the setting, the greater the risk of scalding. Hot water can cause third degree burns in under one (1) second at 160°F (71°C), in five (5) seconds at 140°F (60°C) and in thirty (30) seconds at 130°F (54°C). In households where there are children, physically challenged individuals, or elderly persons, mixing valves for point of use are necessary as means of reducing the scalding potential of hot water.

The gas control is factory-adjusted to its lowest temperature, approximately 70°F (21°C). When the water heater is plugged in for the first time, the gas control will start to heat the water to this temperature. To avoid any unintentional changes in the water temperature settings, the gas control has a tamper-resistant feature included for changing the temperature setting. If you want to change this setting for either cooler or warmer water, the following steps are necessary:

Figure 19

DISPLAY						APPROXIMATE TEMPERATURE °F (°C)	APPROXIMATE TIME TO CAUSE INJURY
▼	A	B	C				
○	○	○	○	○	○	70 (21) (Vacation)	N/A
○	●	○	○	○	○	110 (43)	5 Minutes
○	●	●	○	○	○	115 (46)	
○	○	●	○	○	○	120 (49)	
○	○	●	●	○	○	125 (52)	30 Seconds
○	○	○	●	○	○	130 (54)	
○	○	○	○	●	○	135 (57)	5 Seconds
○	○	○	○	○	●	140 (60)	
○	○	○	○	○	●	145 (63)	1.5 Seconds
○	○	○	○	○	●	150 (66)	
○	○	○	○	○	●	160 (71)	Under 1 Second

FLASHING →

1. “Wake up” the temperature indicators by holding down both the **COOLER** and **HOTTER** temperature adjustment buttons at the same time for one (1) second (see **Operating Instructions**). One or two of the temperature indicators will light up. These indicators will only remain on for thirty (30) seconds, if no further buttons are pressed. After thirty (30) seconds, the control will go back to “Sleep” mode and both buttons will again have to be pressed to see the water temperature setting. Release both of the temperature adjustment buttons.

2. If this is the first time that the control has been used, the leftmost green indicator will be illuminated, indicating the water temperature setting of approximately 70°F (21°C). If the control has been in operation for some time, the water temperature setting may indicate a different temperature. See **Figure 19** for an explanation of what each of the temperature indicators mean.



To decrease the temperature, press and release the **COOLER** button once. The temperature indicators will now display the new temperature setting. Press and release the **COOLER** button until you have reached the desired setting. **HOLDING DOWN THE BUTTON WILL NOT CONTINUE TO LOWER THE SETTING.** The button must be pressed and released for each temperature change desired.

To increase the temperature, press and release the **HOTTER** button once. The temperature indicators will now display the new temperature setting. Press and release the **HOTTER** button until you have reached the desired setting. **HOLDING DOWN THE BUTTON WILL NOT CONTINUE TO RAISE THE SETTING.** The button must be pressed and released for each temperature change desired.

To maximize the efficiency of this water heater and reduce the risk of scalding, it is recommended that the gas control be set at the setting below the large triangle («▼»), which represents approximately 120°F (49°C).

3. When you have completed setting the control, wait thirty (30) seconds to see that the temperature indicators go off and the control enters “Sleep” mode. **ALL OF THE TEMPERATURE INDICATORS WILL BE OFF DURING NORMAL OPERATION.** If at any time you see the indicators on, there may be a system error and you should consult the **Troubleshooting Guide** of this document or call Enercare Home Services at 1-800-266-3939.

When hot water is drawn from the tank in frequent short bursts, a condition known as “stacking” is created. “Stacking” is the result of increased cycling of the burner and can produce very hot water temperatures at the hot water outlet. Always remember to check the hot water coming out of any faucet with your hand before use. This will reduce the risk of scalding-related injuries.

GENERAL MAINTENANCE

The gas control pictured in this manual is equipped with a single-use type automatic high temperature cut-off. Should the temperature of the water exceed 195°F (91°C), the high temperature cut-off will automatically shut off the gas supply to the water heater. If this situation occurs, the gas control must be replaced by Enercare Home Services.

⚠ WARNING

Should overheating occur or the gas supply fail to shut off, close the gas supply manual shut-off valve. Failure to follow this instruction can result in property damage, personal injury, or death.

Out of Fuel

If your water heater should run out of gas, proceed as follows:

- 1) Toggle the "ON/OFF" switch located on the gas control to the "OFF" position.
- 2) Unplug the power cord from the wall socket.
- 3) Close the gas supply manual shut-off valve.
- 4) Once the gas supply has been re-established, proceed to the *Operating Instructions*.

Housekeeping

Keep the area around the water heater clean and free of dust, lint, and dirt. It is the responsibility of the home owner to do so in order to prevent any malfunction that is not Enercare Home Services's responsibility. Verify the combustion air intake holes, at the bottom of the water heater, at least once every six (6) months and vacuum up any dirt, as required. Make sure that all of the minimum clearances to combustible materials are being maintained.

⚠ WARNING

DO NOT store or use gasoline or other flammable vapours and liquids around the water heater.

DO NOT block or, in any way, restrict the flow of fresh air through the combustion air intake holes at the bottom of the water heater.

DO NOT put or store any objects on the top of the water heater.

Failure to follow these instructions can result in property damage, personal injury, or death.

Safety System

This water heater is equipped with a safety system that will shut it down in the event of a flammable vapour incident. It is a safety feature that may prevent property damage, personal injury, or death.

The safety system is comprised of two parts, a flammable vapour (FV) sensor and the flame arrestor. The FV sensor is located on the front left bottom of the exterior casing of the water heater. The FV sensor is protected from shock and contaminants by a robust plastic cover. The function of the FV sensor is to detect the presence of flammable vapours before they enter the combustion chamber and ignite. If the FV sensor detects the presence of flammable vapours while the water heater is operating, the gas control will switch to lock-out mode and the water heater will shut down. If the water heater is not operating when the flammable vapours are detected, the control will switch to lock-out mode and prevent the water heater from lighting.

It is unlikely that there will ever be a flammable vapour ignition in the combustion chamber as the flammable vapours will have been detected by the FV sensor. However, if flammable vapours manage to enter the combustion chamber during main burner operation and ignite, the flame arrestor technology will prevent ignition of the vapours outside the combustion chamber.

After a flammable vapour incident has occurred and the flammable vapours have dissipated, the FV sensor is designed to automatically reset itself. The gas control, however, will have gone into lock-out mode and will need to be manually reset. Enercare Home Services must be called at 1-800-266-3939 to determine if flammable vapours entered the combustion chamber and ignited. In most instances, there will not have been ignition of flammable vapours inside the combustion chamber because the FV sensor will have detected these vapours and shut down the water heater. In this case, the gas control can be reset and the water heater may resume normal operation. On the other hand, if the flammable vapours ignited inside the combustion chamber, the water heater may need to be replaced. The technician will be able to determine whether or not the water heater needs to be replaced based on the amount of flammable vapours that entered the combustion chamber and the damage to the water heater from the resulting fire.

GENERAL MAINTENANCE

Condensation

As moisture from the products of combustion comes into contact with the cold surface of the inner tank, it may condense. This situation will usually occur:

- 1) When the water heater is filled with cold water for the first time.
- 2) If the water heater has been undersized.
- 3) When large amounts of hot water are drawn from the water heater in a short period of time and the refill water is very cold.

Due to the high-efficiency rating of this gas-fired water heater, it may produce more condensation than older models. Condensation forming on the flue tube will drop on the burner making a “sizzling” sound. This condition is not uncommon and must never be misinterpreted as a leaking tank. It will disappear once the water becomes heated.

Burner Ignitor Assembly

Periodically, check the burner and ignitor assembly. Remove the outer access door and look through the sight glass to examine the flames. A soft blue flame indicates proper gas combustion. A yellow tipped flame indicates poor combustion. If so, with a vacuum cleaner, remove any dust, lint, and dirt accumulation on or around the combustion chamber and in the combustion air intake holes. If the poor combustion persists and there is no lint around the water heater, call Enercare Home Services at 1-800-266-3939. This service call may be at the expenses of the consumer if lint is blocking the flame arrestor plate.

Temperature and Pressure-Relief Valve

On a regular basis, visually inspect the valve for any leakage, if so call Enercare Home Services at 1-800-266-3939.

Venting System Inspection

The venting system must be thoroughly inspected once a year. Check the area where the water heater is located to make sure that there is enough clean combustion and ventilation air. Remove any possible obstructions that would prevent proper air circulation and venting. Check the venting system to make sure that all of the connections are securely fastened and that all of the joints are properly sealed. If any part of the venting system is damaged, it must be replaced by Enercare Home Services at 1-800-266-3939. Inspect vent terminal screen and clean as required.

Anodes

⚠ WARNING

The cap covering the anodes on top of the water heater **MUST BE** put back in place after servicing the anodes.

This water heater is equipped with two (2) anodes that are designed to prolong the life of the glass-lined tank. The anodes are slowly consumed, protecting the glass-lined tank from corrosion. The anodes should be checked periodically. If you get rotten egg smell, call Enercare Home Services at 1-800-266-3939 that may have a solution to your water condition problem (See the explanation of rotten eggs below).

The life expectancy of the water heater is reduced where a water softener is introduced to fight hard water, because the sodium salts added by a softener make this water extremely conductive. Under these conditions, the magnesium anodes must be replaced by aluminum anodes approved by the manufacturer, along with the addition of zinc pellets.

Please advise Enercare Home Services that you operate a water softener so they can take the proper precaution.

In certain water conditions, the magnesium anodes will react with the water, producing discoloured or smelly water. The most common complaint is hot water that smells like rotten eggs. This phenomenon is the result of the reaction between the magnesium anodes and hydrogen sulfide gas dissolved in the water, which occurs frequently in well systems. This problem can usually be eliminated or reduced by changing the anodes to aluminum anodes combined with zinc pellets and by chlorinating the water heater and the plumbing system. If the problem persists, special filtration equipment may be required. Under no circumstances are the anodes to be removed from the water heater on a permanent basis. **Removal of the anodes will lead to premature failure of the water heater and void the warranty.**

This is not an Enercare Home Services issue but a consumer issue in their water supply and the consumer is responsible for any equipment needed to remove the rotten egg smell.

⚠ WARNING

Hydrogen gas can be produced in a hot water system that has not been used for a long period of time (generally two [2] weeks or more). **HYDROGEN GAS IS EXTREMELY FLAMMABLE.** It is highly recommended to open the hot water faucet in the kitchen for several minutes before you use any electrical appliances connected to the hot water system, such as a dishwasher or washing machine. If hydrogen gas is present, there will be an unusual sound, such as air escaping through the pipe, as the hot water faucet is opened. **DO NOT** smoke or introduce an open flame near the faucet when it is opened.

GENERAL MAINTENANCE

Draining the Water Heater

Drain a pail of water through the drain valve at your convenience in very hard water conditions. This will remove excess sediment from the bottom of the tank. This sediment, if allowed to accumulate, will reduce the efficiency and the life of the tank.

To completely drain the water heater:

- 1) Toggle the "ON/OFF" switch located on the gas control to the "OFF" position.
- 2) Unplug the power cord from the wall socket.
- 3) Close the gas supply manual shut-off valve.
- 4) Close the cold water supply manual shut-off valve.
- 5) Connect one end of a garden hose to the water heater drain valve and put the other next to a free-flowing drain.
- 6) Open the drain valve by inserting a flat head screwdriver into the slot on the head of the drain valve and turning the knob counterclockwise  .
- 7) Open a hot water faucet to allow air into the system.

Vacation

If you are planning a vacation or other prolonged absence, it is highly recommended to shut off the gas supply and the cold water supply to the water heater. This will save energy, protect against property damage in the event the water heater leaks and prevent the build-up of hydrogen gas. If the water heater and piping are exposed to freezing temperatures, they should both be drained.

Remember to check the water heater thoroughly after it has been shut off for an extended period of time before putting it back in operation. Make sure that the water heater is completely full of water and that the cold water supply manual shut-off valve is open, before lighting the burner.

Service Procedure

If you are experiencing problems with your water heater, please call Enercare Home Services at: 1-800-266-3939. Have handy the following:

- a) Name.
- b) Address.
- c) Contract number.
- d) Telephone number.
- e) Other people to reach in case of emergency.
- f) A description of the problem.

REPLACEMENT PARTS



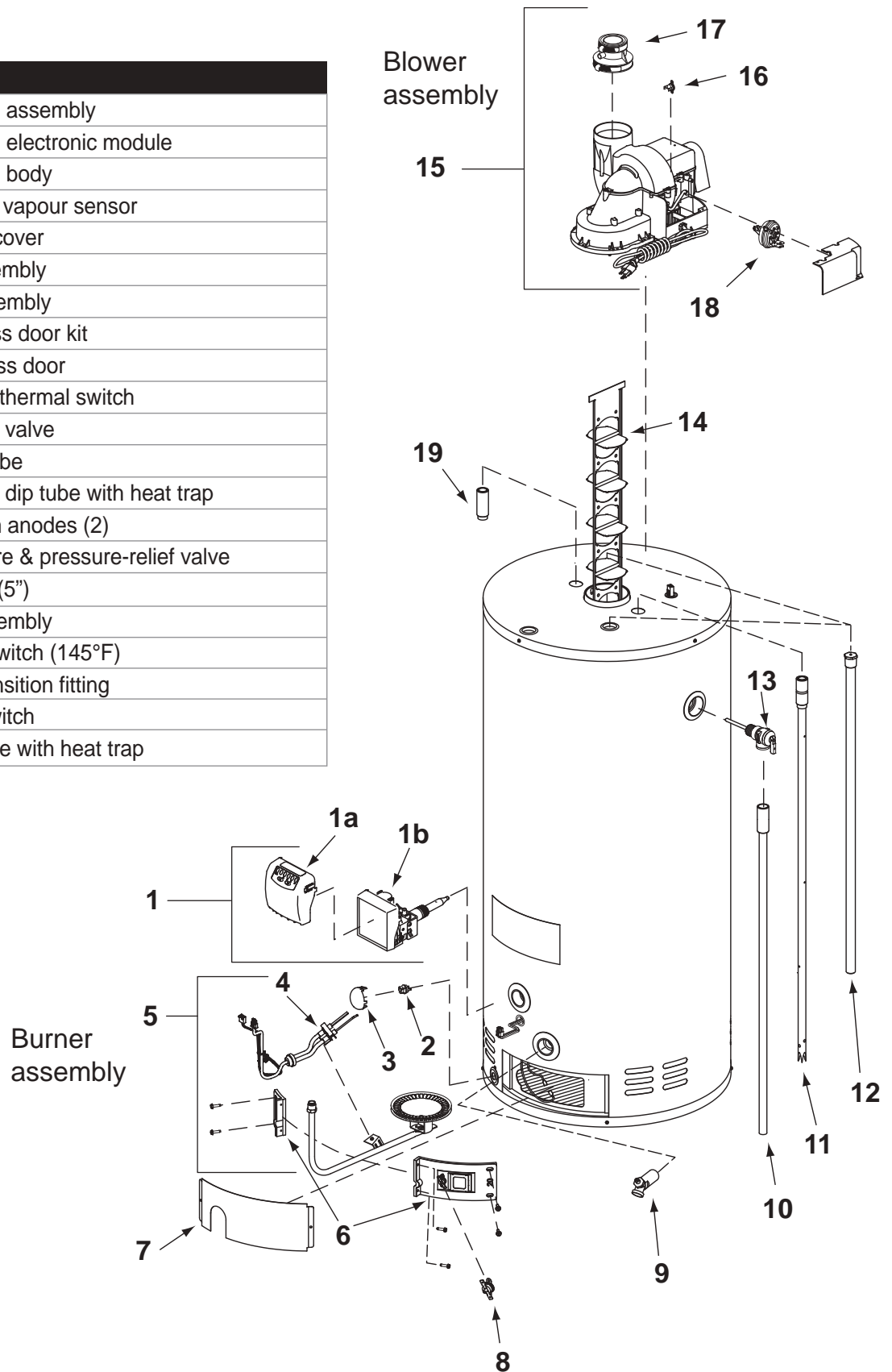











ID No.	Description
1	Gas control assembly
1a	Gas control electronic module
1b	Gas control body
2	Flammable vapour sensor
3	Protective cover
4	Ignitor assembly
5	Burner assembly
6	Inner access door kit
7	Outer access door
8	Resettable thermal switch
9	Brass drain valve
10	Overflow tube
11	Closed end dip tube with heat trap
12	Magnesium anodes (2)
13	Temperature & pressure-relief valve
14	Flue baffle (5")
15	Blower assembly
16	High limit switch (145°F)
17	Rubber transition fitting
18	Vacuum switch
19	Outlet nipple with heat trap

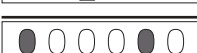

TROUBLESHOOTING GUIDE

⚠ WARNING

Disconnect the electrical power before servicing the water heater. Service should only be performed by Enercare Home Services. Failure to follow these instructions can result in personal injury or death.

CONDITION (code#)	CAUSE	CORRECTIVE ACTION
	1 An open earth ground circuit to the ignition.	<ol style="list-style-type: none"> 1) Check that the earth ground conductor is properly connected at the fuse box or breaker panel and the water heater. 2) Check that the grounding conductors on the water heater are properly connected and secure.
	2 A wiring error or a high resistance to earth ground.	<ol style="list-style-type: none"> 1) Check for proper connection of the line neutral and line hot wires. 2) Check that the water heater is securely connected to earth ground.
	3 The pressure switch remained closed longer than 5 seconds after the call for heat began.	<ol style="list-style-type: none"> 1) The pressure switch wiring is incorrect. 2) The pressure switch is defective and must be replaced.
	4 The pressure switch remained open longer than 5 seconds after the power vent was energized. (see note at the bottom of the page)	<ol style="list-style-type: none"> 1) The pressure switch wiring is incorrect. 2) The pressure switch tubing is not properly connected. 3) There are obstructions or restrictions in the water heater air intake or exhaust flue.
	5 The self diagnosing test has detected an error in the hot surface ignitor circuit.	<ol style="list-style-type: none"> 1) Check the wiring is correct and secure. 2) Disconnect the ignitor connector and measure the ignitor resistance with an accurate ohmmeter between pins 1 and 2. Resistance should be between 11.5 and 18.8 ohms. If the reading is incorrect, replace the hot surface ignitor. 3) If the above checks are good, replace the gas control.
	6 The maximum number of ignition retries or recycles has been reached and the system is in lock-out mode.	<ol style="list-style-type: none"> 1) Check if the gas supply is off or too low to operate. 2) Check the flame sensor rod to see if it is located properly and free from contamination. Reposition the flame sensor rod or lightly clean it with an abrasive cloth. 3) The hot surface ignitor may not be positioned correctly. Reposition as necessary. 4) Check that the hot surface ignitor and flame sensor rod are wired correctly and in good working condition. 5) Low voltage to the water heater. Check and repair.
	7 The gas valve driver circuit.	<ol style="list-style-type: none"> 1) Turn off the power to the water heater for 10 seconds and then back on. 2) If the above step did not clear the error, replace the gas control.
	8 The internal microcomputer.	<ol style="list-style-type: none"> 1) Turn off the power to the water heater for 10 seconds and then back on. 2) If the above step did not clear the error, replace the gas control.
	9 The internal circuit.	<ol style="list-style-type: none"> 1) Turn off the power to the water heater for 10 seconds, verify the polarity and then back on 2) If the above step did not clear the error, replace the gas control.
	10 Flame signal sensed out of proper sequence.	Replace the gas control.
	11 The high temperature thermal cut-off is open.	Replace the gas control.
	12 One of the temperature adjust buttons is stuck closed.	<ol style="list-style-type: none"> 1) Make sure that there are no objects leaning against the front of the control. 2) Lightly press and release each of the buttons once. 3) If the above actions do not clear the error, the control will continue to regulate the water temperature at the last setting, but you will not be able to change settings unless you replace the gas control.
	13 The water temperature sensor is either open or short-circuited.	<ol style="list-style-type: none"> 1) Check that all of the wiring is correct and that there are no open or short circuits. 2) If no wiring problems are found, the gas control must be replaced.
	14 The self-diagnosing test found a problem with the flammable vapour sensor.	<ol style="list-style-type: none"> 1) Check that all wiring is correct and that there are no open or short circuits. 2) If no wiring problems are found, the flammable vapour sensor must be replaced.
	15 The control detected the presence of flammable vapours near the appliance and entered lock-out mode.	<ol style="list-style-type: none"> 1) Identify the source of the flammable vapours and remove it from the area surrounding the water heater. 2) Contact Enercare Home Services at 1-800-266-3939 to have the water heater inspected immediately.
	16 Weak Flame Current.	<ol style="list-style-type: none"> 1) Check that the flame sense rod to see if it is properly located and free from contamination. Reposition the flame sense rod or lightly clean with an abrasive cloth. 2) Low voltage to the water heater. Check and repair.



Note for models with a manual reset only: Since the high limit switch on the blower is in series with the pressure switch, the problem could be that the high limit switch tripped. Reset the high limit Switch by pressing on the red button in the middle of the switch.

TROUBLESHOOTING GUIDE

Only Enercare Home Services personnel can service your rental water heater,
call 1-800-266-3939 for service.

CONDITION	CAUSE	CORRECTIVE ACTION
The burner will not ignite.	No gas.	Check with gas utility company.
	Dirt in gas line.	Notify utility company. Install drip leg in gas line.
	Combustion air intake holes blocked.	With a vacuum cleaner, remove dirt, dust, and lint.
	Main burner line clogged.	Clean. Check for source of trouble and correct.
	Defective flame sensor.	Replace with new flame sensor.
	Defective gas control.	Replace with new gas control.
	Gas control set too low.	Turn temperature dial to desired temperature.
	Heater installed in a confined area.	Provide fresh air ventilation.
The burner flame floats and lifts off ports.	High gas pressure.	Check with gas utility company.
	Orifice too large.	Replace with correct orifice.
	Flue clogged.	Clean. Check for source of trouble and correct.
	Combustion air intake holes blocked.	With a vacuum cleaner, remove dirt, dust, and lint.
	Heater installed in a confined area.	Provide fresh air ventilation.
	Cold drafts (downdraft).	Locate source and correct.
Vacuum switch located in the blower assembly remain open.	One of the potential causes is excessive dirt, dust, and other debris accumulation on the flame arrestor and on the blower impeller.	Clean the flame arrestor in the combustion chamber using a stiff brush, compressed air and/or a vacuum cleaner. In no circumstances, the blower assembly should be removed for cleaning or replaced without contacting Enercare Home Services at 1-800-266-3939.
The burner flame is yellow and lazy.	Insufficient secondary air.	Provide fresh air ventilation.
	Flue clogged.	Clean. Check for source of trouble and correct.
	Combustion air intake holes blocked.	With a vacuum cleaner, remove dirt, dust, and lint.
	Main burner line clogged.	Clean. Check for source of trouble and correct.
	Heater installed in a confined area.	Provide fresh air ventilation.
The burner flame is too high.	Insufficient secondary air.	Provide fresh air ventilation.
	Orifice too large.	Replace with correct orifice.
	Defective gas control.	Replace with new gas control.
The flame burns at the orifice.	Low gas pressure.	Check with gas utility company.
	Defective gas control.	Replace with new gas control.
High operating costs.	Gas control set too high.	Turn temperature dial to desired temperature.
	Sediment or lime in tank.	Drain. Check to see if water treatment is necessary.
	Water heater is undersized.	Install size of water heater that meets demand.
	Wrong piping connections.	Correct piping, dip tube must be in cold inlet.
	Leaking faucets.	Repair faucets.
	Gas leaks.	Check with gas utility company. Repair at once.
	Wasted hot water.	Advise consumer.
	Long runs or exposed piping.	Insulate piping.
	Hot water piping on outside wall.	Insulate piping.
Insufficient hot water.	Low gas pressure.	Check with gas utility company.
	Wrong piping connections.	Correct piping, dip tube must be in cold inlet.
	Sediment or lime in tank.	Drain. Check to see if water treatment is necessary.
	Water heater is undersized.	Install the size of water heater that meets the demand.
	Gas control set too low.	Turn temperature knob to desired temperature.
	Leaking faucets.	Repair faucets.
	Wasted hot water.	Advise consumer.
	Long runs or exposed piping.	Insulate piping.
	Hot water piping on outside wall.	Insulate piping.
Slow hot water recovery.	Insufficient secondary air.	Provide fresh air ventilation.
	Low gas pressure.	Check with gas utility company.
	Gas control set too low.	Turn temperature dial to desired temperature.
	Improper calibration.	Replace gas control.
	Flue clogged.	Clean. Check for source of trouble and correct.
	Water heater is undersized.	Install size of water heater that meets demand.
	Wrong piping connection.	Correct piping, dip tube must be in cold inlet.
	Wasted hot water.	Advise consumer.

TROUBLESHOOTING GUIDE

Only Enercare Home Services personnel can service your rental water heater, call 1-800-266-3939 for service.

CONDITION	CAUSE	CORRECTIVE ACTION
Leaking water.	Poorly sealed, hot or cold water connections, gas control threads, relief valve, or drain valve.	Tighten threaded connections.
	Leakage from plumbing system or other appliances.	Inspect plumbing system and other appliances.
	Condensation.	Refer to Condensation .
Water drips from the relief valve.	Heater stacking.	Lower gas control setting.
	Excessive water pressure.	Install a pressure-reducing valve.
	Thermal expansion in a closed water system.	Install an expansion tank.
	Improperly seated valve.	Check relief valve works properly and replace, if necessary.
The gas control fails to shut off.	Defective gas control.	Replace with new gas control.
	Improper calibration.	Replace gas control.
Condensation.	Water heater filled for the first time.	Let water heater warm up. Problem should go away. If it persists, check all plumbing connections for leaks.
	Heavy draws of hot water with very cold refill water.	Let water heater warm up. Problem should go away. If it persists, check all plumbing connections for leaks.
	Water heater is undersized.	Install size of water heater that meets demand.
Combustion odours.	Insufficient secondary air.	Provide fresh air ventilation.
	Heater installed in a confined area.	Provide fresh air ventilation.
	Flue clogged.	Clean. Check for source of trouble and correct.
Smoking and carbon formation (sooting).	Insufficient secondary air.	Provide fresh air ventilation.
	Low gas pressure.	Check with gas utility company.
	Burner flame yellow, lazy.	Refer to The burner flame is yellow and lazy .
	Flue clogged.	Clean. Check for source of trouble and correct.
	Defective gas control.	Replace with new gas control.
	Heater installed in a confined area.	Provide fresh air ventilation.
Smelly water.	High sulfate or mineral content in water.	Change magnesium anode to an aluminum anode and bleach tank.
The access door temperature high limit switch is tripping.	Not enough draft from the venting system.	Check for any obstruction in the chimney. Ensure that the chimney is sized and installed according to installation instructions provided in this manual.
	Not enough fresh air for the combustion.	Supply make-up air. Refer to installation instructions provided in this manual.
	Ambiant air temperature is too high.	Reduce ambient air temperature.
	Excessive dirt, dust, or other debris accumulation on the flame arrestor.	Clean the flame arrestor in the combustion chamber using a stiff brush, compressed air and/or a vacuum cleaner.

MODEL DIMENSIONS

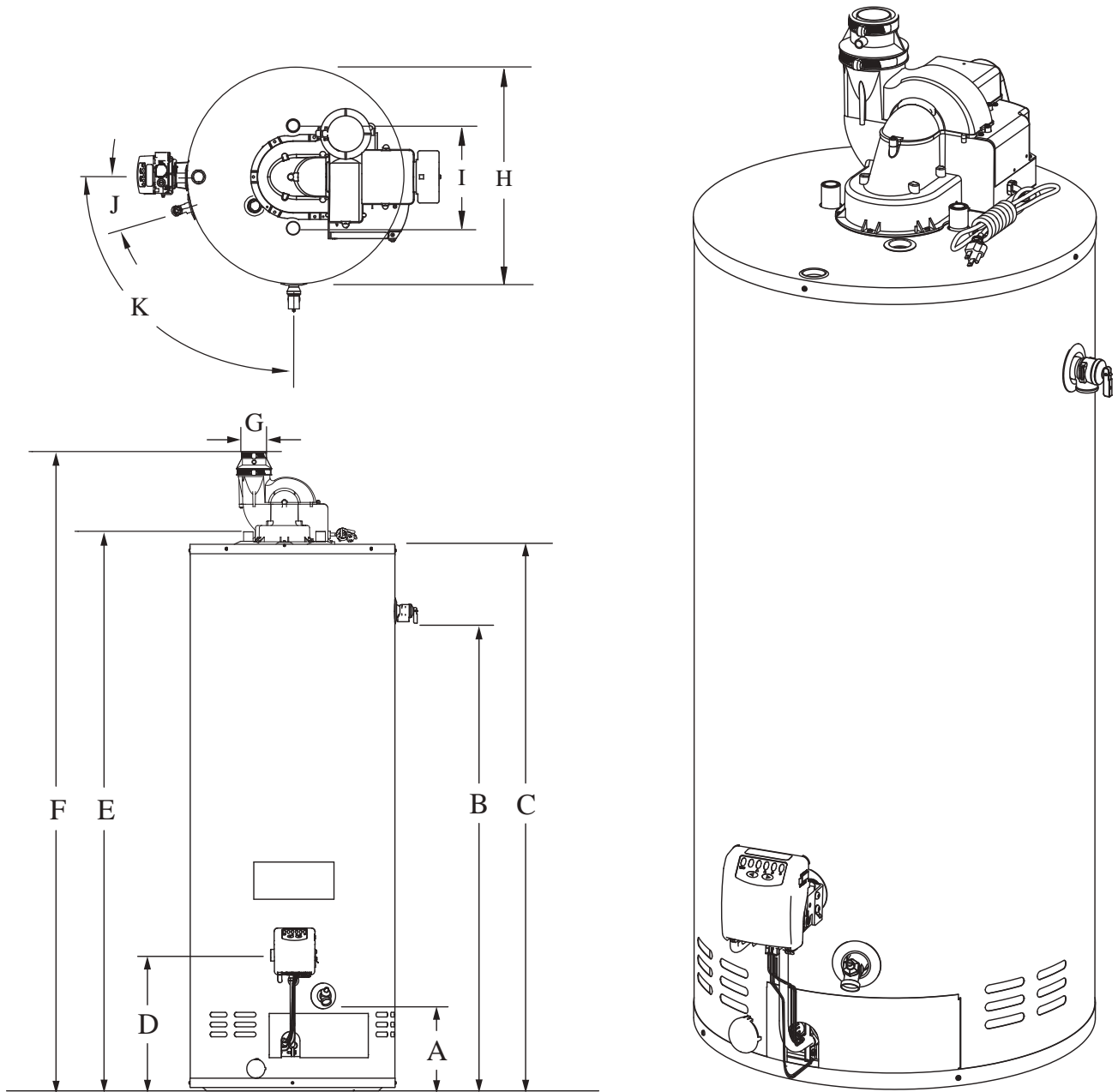

DIMENSIONS inches (cm)												
Models	A	B	C	D	E	F	G	H (-*1U)	H (-*2U)	I	J	K
All UG40	7 1/4 (18)	40 1/8 (102)	48 3/8 (123)	12 1/8 (31)	49 7/8 (127)	58 1/2 (149)	2 (5)	20 1/2 (52)	22 (56)	8 (20)	17.4°	90.0°
All UG50	7 1/4 (18)	40 3/16 (102)	48 3/8 (123)	12 1/8 (31)	49 7/8 (127)	58 1/2 (149)	2 (5)	22 1/2 (57)	23 1/2 (60)	8 (20)	15.6°	90.0°
All UG60	7 1/8 (18)	48 (122)	56 1/2 (144)	12 (31)	57 7/8 (147)	66 5/8 (169)	2 (5)	-	23 1/2 (60)	8 (20)	15.6°	90.0°



enercare™

enercare.ca

™Enercare and the design are trademarks of Enercare Inc., used under license.