

RESIDENTIAL GAS-FIRED WATER HEATERS

(EQUIPPED WITH FVIR TECHNOLOGY)

OWNER'S MANUAL

INSTALLATION AND OPERATING INSTRUCTIONS

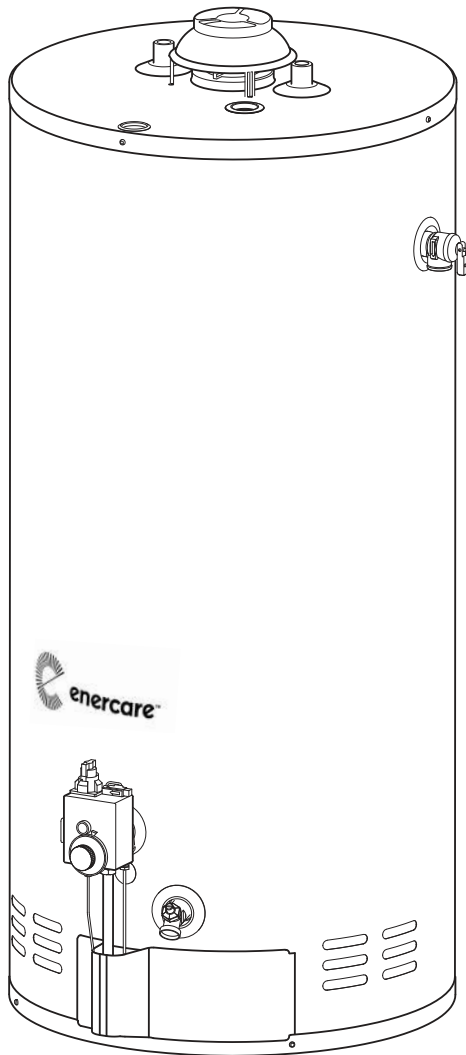

⚠ WARNING

This water heater **IS NOT** design certified for installation in a manufactured (mobile) home or for installation outdoors.

⚠ WARNING

If the information in these instructions is not followed exactly, a fire or explosion may result causing property damage, personal injury, or death.

DO NOT store or use gasoline or other flammable vapours and liquids in the vicinity of this or any other appliance.

WHAT TO DO IF YOU SMELL GAS

- **DO NOT** try to light any appliance.
- **DO NOT** touch any electrical switch.
- **DO NOT** use any phone in your building.
- **From a neighbour's phone, immediately call your gas supplier.**
Follow their instructions.
- If you cannot reach immediately the above supplier, call the fire department at 911.

Installation and service must be performed only by Enercare Home Services at 1-800-266-3939.

IMPORTANT

READ THESE INSTRUCTIONS CAREFULLY BEFORE BEGINNING THE INSTALLATION. PROPER INSTALLATION WILL PROVIDE SAFE & EFFICIENT SERVICE, AND AVOID NEEDLESS EXPENSE NOT COVERED BY THE WARRANTY. SHOULD YOU HAVE ANY QUESTIONS, PLEASE CONTACT ENERCARE HOME SERVICES AT 1-800-266-3939.

SAVE THIS MANUAL FOR FUTURE REFERENCES.



C US
LOW LEAD
CONTENT



TABLE OF CONTENTS

Safety Information	3
Installation Instructions	4
Altitude	4
Location	4
Minimum Clearances	4
Combustion and Ventilation Air Supply	4
Requirements for Unconfined Spaces	5
Requirements for Confined Spaces.....	5
Louvers and Grilles.....	6
Corrosive Atmospheres	6
Venting.....	6
Draft hood	7
Venting System.....	7
Water Piping	7
Temperature & Pressure-Relief Valve	8
Pressure Build-up in a Water System	9
Filling the Water Heater.....	9
Gas Connections	9
Installation Instructions for Water Heaters Approved for Space Heating & Potable Water Heating	10
Installation Checklist	10
Operating Instructions	11
Lighting the Water Heater.....	11
Draft Hood Operation.....	12
Water Temperature Regulation	12
Out of Fuel.....	12
General Maintenance	13
Housekeeping.....	13
Condensation.....	13
Main Burner & Pilot.....	13
Water Heater Tank	13
Temperature and Pressure-Relief Valve	13
Venting System Inspection	13
Anodes.....	13
Draining the Water Heater.....	14
Vacation	14
Getting Service for your Water Heater	14
Replacement Parts	15
Troubleshooting Guide	16

FVIR technology equipped with flame arrestor

This water heater is equipped with the new FVIR technology. In the event that gasoline or other flammable vapours and liquids are improperly stored in the area where the water heater is located, the flame arrestor will prevent these combustible vapours from igniting outside of the water heater.

Activation of the FVIR technology occurs when flammable vapours are drawn into the combustion chamber of the water heater and ignite. If flammable vapours are detected:

- **DO NOT** try to light any appliance.
- **DO NOT** touch any electrical switch, **DO NOT** use any phone in your building.
- **From a neighbour's phone, immediately call your gas supplier.**
Follow their instructions.
- If you cannot reach this supplier, call the fire department at 911.

Immediately contact Enercare Home Services at 1-800-266-3939. **Replacement of a FVIR technology equipped water heater due to a flammable vapour shutdown is not covered under Enercare rental program and service agreement.**

SAFETY INFORMATION

Your safety and the safety of others is extremely important during the installation, operation, and servicing of this water heater. Many safety related messages have been provided in this manual and on your water heater. Always read and obey all safety messages. These messages will point out the potential hazard, tell you how to reduce the risk of injury, and tell you what will happen if these instructions are not followed.



This is the safety alert symbol. This symbol alerts you to potential hazards that can kill or hurt you and others. All safety messages will follow the safety alert symbol and either the word “DANGER” or “WARNING”.



DANGER

Serious injury or death can occur if you do not follow the instructions immediately.



WARNING

Serious injury or death can occur if you do not follow the instructions.



WARNING



FIRE AND EXPLOSION HAZARD

Can result in serious injury or death

⚠ Do not store or use gasoline or other flammable vapours and liquids in the vicinity of this or any other appliance. Storage of or use of gasoline or other flammable vapours or liquids in the vicinity of this or any other appliance can result in serious injury or death.



WARNING

DO NOT use this water heater if any part has been under water. Immediately call **Energcare Home Services** at 1-800-266-3939 to inspect the water heater. Energcare will have the final decision as to how to handle the situation.

INSTALLATION INSTRUCTIONS

IMPORTANT

These instructions have been written as a guide for the proper installation and operation of your water heater, and the manufacturer of this water heater will not accept any liability where these instructions have not been followed. However, for your safety and to avoid damage caused by improper installation, this water heater must be installed by an Enercare Certified Licensed Professional, and meet all local codes or, in the absence of local codes, CSA B149.1 Natural Gas and Propane Installation Code, in Canada, and/or the National Fuel Gas Code, ANSI Z223.1, in the United States.

Before proceeding with the installation instructions:

- 1) Inspect the water heater and its component parts for possible damage. **DO NOT** install or attempt to repair any damaged component parts. If you detect any damage, contact **Enercare Home Services** at 1-800-266-3939.
- 2) Verify that the type of gas being supplied corresponds to the one marked on the rating plate and gas control of the water heater.

Altitude

Input rating of this water heater is based on sea level operation. At higher elevations, the actual input rate will be lower than the value listed on the rating plate due to the natural derating of natural gas and propane. **DO NOT** attempt to adjust the input rate by changing the manifold pressure. Refer to the rating plate on the water heater for the certified elevation at which your specific model can be installed.

WARNING

Failure to install a water heater suitable for the altitude at the location it is intended to serve, can result in improper operation of the appliance resulting in property damage and/or producing carbon monoxide gas, which could result in personal injury or death.

Location

The water heater should be located as close as possible to the chimney and to the main use of hot water. This location must not be subject to freezing temperatures. The water heater should be positioned, so that there is easy access to the burner, gas control, and drain valve. Where a floor drain is not adjacent to the water heater, it is recommended that a suitable drain pan be installed under the water heater (**see Figure 8**). This drain pan should not be less than two (2) inches (5 cm) larger than the tank and have side walls not less than one (1) inch (2.5 cm) high providing access to the water heater drain valve. This pan must not restrict the flow of ventilation and combustion air. This pan must be piped to a suitable drain to prevent damage to property in the event of a water leak from the piping, the relief valve, or the water heater.

Sooner or later, all water heaters leak. The manufacturer, based on national building codes, has given the necessary instructions to prevent damage to the building. Under no circumstances is the manufacturer to be held liable for any water damage in connection with this water heater.

This water heater is approved for installation on either a combustible or non-combustible floor. However, should this water heater be installed directly on carpeting, such carpeting must be protected by a wood or metal panel beneath the water heater. This panel must extend at least three (3) inches (7.62 cm) beyond the width and depth of the water heater. Should the water heater be installed in an alcove or closet, the entire floor area must be covered by the panel.

Minimum Clearances

The minimum clearances from combustible material for this water heater are: Two (2) inches (5.1 cm) from the sides and rear, four (4) inches (10.2 cm) from the front, and eighteen (18) inches (45.7 cm) from the top (**see Figure 1**).

Figure 1

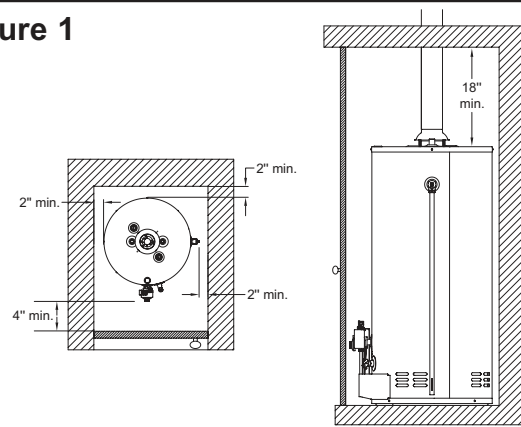

Combustion and Ventilation Air Supply

In order for the water heater to operate properly, it must be supplied with an uninterrupted flow of clean combustion and ventilation air. The area around the water heater must always be kept clear and the combustion air intake holes at the bottom of the water heater must never be blocked. An inadequate supply of air to the water heater will produce a bright yellow burner flame causing sooting in the combustion chamber, on the burner, and in the flue tube. This

INSTALLATION INSTRUCTIONS

can result in damage to the water heater and serious bodily injury, if not corrected.

Combustion and ventilation air requirements are determined by where the water heater is to be located. Water heaters are installed in either open (unconfined) spaces or smaller (confined) spaces, such as closets or small rooms.

Requirements for Unconfined Spaces

An unconfined space is an area with at least fifty (50) cubic feet for each 1,000 Btuh (4.8 m³/kW) of the total input rating for all gas appliances installed in that space. Water heaters installed in unconfined spaces do not usually require outdoor air to function properly. However, in buildings with tight construction (heavy insulation, vapour barriers, weather stripping, etc.), and particularly in modern buildings, additional fresh air may need to be provided. For instructions on obtaining additional air supply, see the requirements below for confined spaces.

Requirements for Confined Spaces

A confined space is an area where the volume is less than fifty (50) cubic feet for each 1,000 Btuh (4.8 m³/kW) of the total input rating for all gas appliances installed in that space. Water heaters installed in confined spaces require additional combustion and ventilation air. This can be provided in two ways:

In Canada refer to CSA B149.1 and local codes for detailed information.

1) All air from Inside the building:

The enclosure in which the water heater is installed shall be provided with two (2) permanent openings of one (1) square inch per 1,000 Btuh (22.0 cm²/kW) of the total input of all appliances and shall communicate directly with one or more rooms of sufficient volume, so that the combined volume of all spaces meets the criteria for an unconfined space for all the appliances installed in that enclosure. A water heater of 50,000 Btuh or less could, in some cases, not require fresh air from outside. Please refer to the current B149.1 code and local codes for further details.

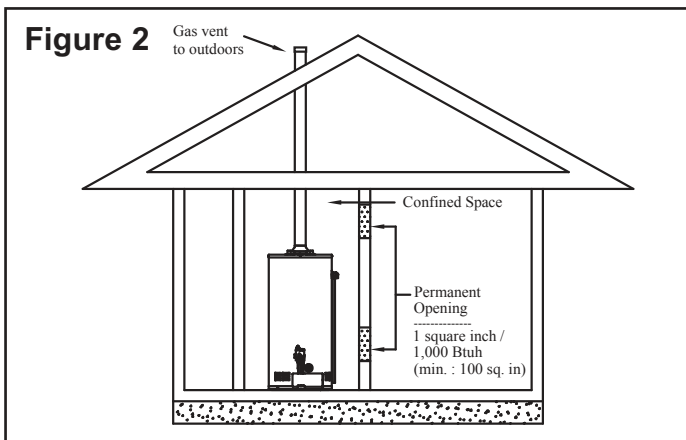

One opening shall be located not more than eighteen (18) inches (45.7 cm) or less than six (6) inches (15.2 cm) above the floor level. The second shall be located as near the ceiling as practical, but in no case lower than the draft hood.

2) All air from outdoors (see Figure 3):

An air supply shall be provided with one opening that communicates directly with the outdoors or by means of a duct. This duct shall be sized according to CSA B149.1 and terminate within one (1) foot (30.5 cm) above, and within two (2) feet (61 cm) horizontally from the burner level of the appliance having the largest input.

In U.S.A. (refer to ANSI Z223.1/NFPA 54 and local codes for detailed information.

1) All air from inside the building (see Figure 2):

The confined space shall be provided with two (2) permanent openings communicating directly with one or more rooms of sufficient volume, so that the combined volume of all spaces meets the criteria for an unconfined space. The total input rating of all gas appliances installed in the combined space shall be considered in making this determination.

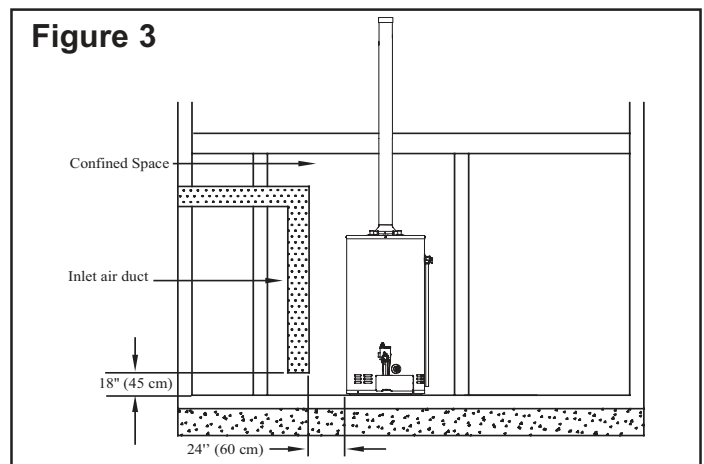

Each opening shall have a minimum free area of one (1) square inch per 1,000 Btuh (22.0 cm²/kW) of the total input rating of all gas appliances in the confined space, **but not less than one hundred (100) square inches (645.16 cm²)**. One opening shall commence within twelve (12) inches (30.5 cm) of the top and one within twelve (12) inches (30.5 cm) of the bottom of the enclosure.

2) All air from outdoors:

The confined space shall be provided with two permanent openings, the first opening within twelve (12) inches (30.5 cm) of the top and one commencing within twelve (12) inches (30.5 cm) from the bottom of the enclosure. The openings shall communicate directly, or by ducts, with the outdoors or spaces (crawl or attic) that freely communicates with the outdoors.

INSTALLATION INSTRUCTIONS

A) When communicating directly with the outdoors, each opening shall have a minimum free area of one (1) square inch per 4,000 Btuh (5.5 cm²/kW) of the total input rating of all gas appliances in the confined space (see Figure 4).

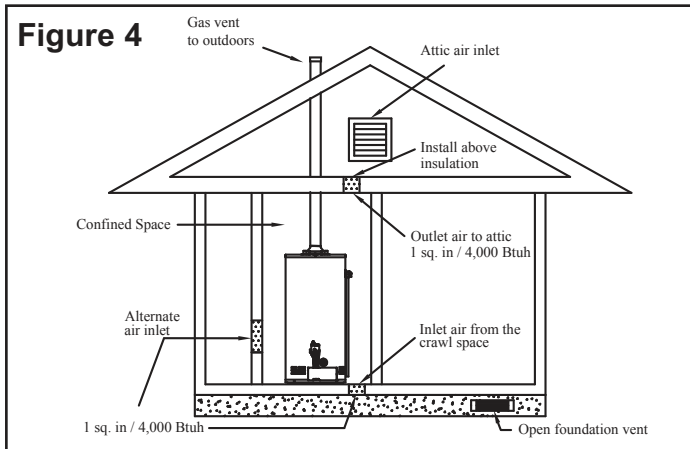

B) When communicating with the outdoors through vertical ducts, each opening shall have a minimum free area of one (1) square inch per 4,000 Btuh (5.5 cm²/kW) of the total input rating of all gas appliances in the confined space (see Figure 5).

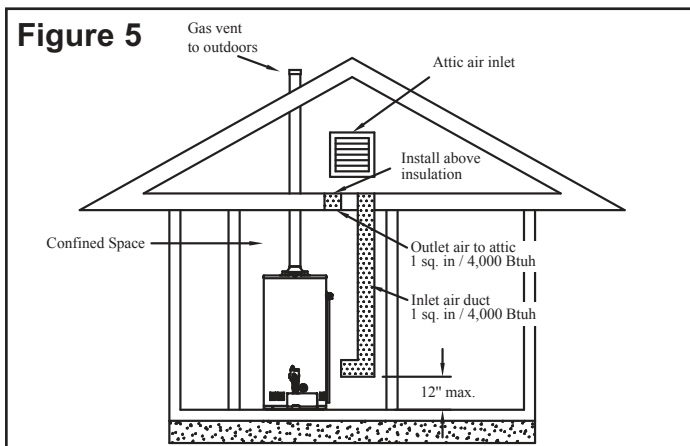

C) When communicating with the outdoors through horizontal ducts, each opening shall have a minimum free area of one (1) square inch per 2,000 Btuh (11.0 cm²/kW) of the total input rating of all gas appliances in the confined space (see Figure 6).

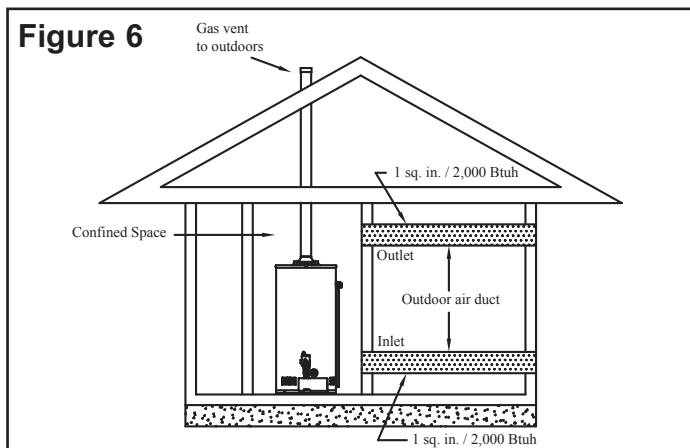

When ducts are used, they shall be of the same cross-sectional area as the free area of the openings to which they connect. The minimum short side dimension of rectangular air ducts shall not be less than three (3) inches (7.62 cm).

Louvers and Grilles

In calculating free area for ventilation and combustion air supply openings, consideration must be given to the blocking effect of louvers, grilles, or screens protecting the openings. Screens must not be smaller than 1/4 inch (6.4 mm) mesh. If the free area through a particular design of louver or grille is known, it should be used in calculating the size of opening required to provide the free area specified. If the design and free area is not known, it may be assumed that wood louvers and grilles will allow 20-25% free area and metal louvers and grilles will allow 60-75% free area. Louvers and grilles must be installed in the open position or interconnected with the water heater so that they are opened automatically during water heater operation (automatic mechanical louvers).

Corrosive Atmospheres

If this water heater will be installed in a beauty shop, barber shop, photo processing lab, dry cleaning establishment, a building with an indoor pool, or near a chemical storage area, it is imperative that the combustion and ventilation air be drawn from outside these areas. These particular environments contain products such as aerosol sprays, detergents, bleaches, cleaning solvents, refrigerants, and other volatile compounds that, in addition to being highly flammable, become highly corrosive acid compounds when burned. Exposure to such compounds can be hazardous and lead to premature product failure. **Should the water heater fail due to exposure to such a corrosive atmosphere, the warranty is void. Enercare may be entitled for compensation.**

Venting

DANGER

When installing the venting system, make sure to follow all local codes or, in the absence of local codes, CSA B149.1 in Canada and/or the National Fuel Gas Code, ANSI Z223.1 in the United States. Never operate the water heater unless it is properly ventilated to the outdoors and has adequate air supply for proper operation. Failure to properly install the venting system could result in property damage, personal injury, or death.

INSTALLATION INSTRUCTIONS

Draft hood

The water heater must be vented using the draft hood provided by the manufacturer. Before installing the draft hood, check to make sure that the flue baffle has been installed in the flue tube. If the flue baffle is missing, immediately contact Enercare Home Services at 1-800-266-3939. Never operate the water heater without the flue baffle installed.

To install the draft hood, place it over the flue opening on the top of the water heater. When installing the draft hood do not alter it in any way.

UG30 and UG40 Models

Line up the holes in the draft hood's legs with those of the water heater's top and secure the draft hood using the two (2) sheet metal screws provided (see **Figure 7a**).

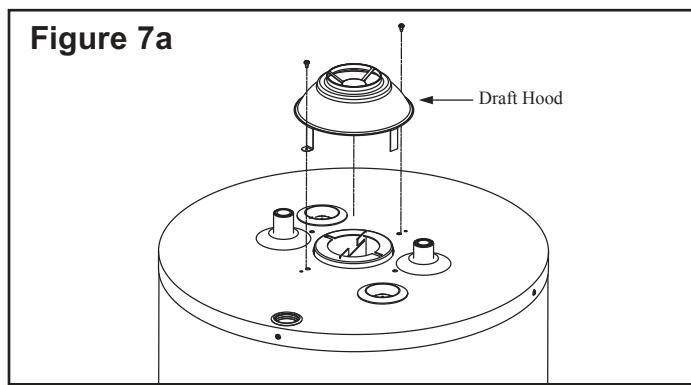

UG50 and UG60 Models

Line up the legs of the draft hood with the holes with those of the water heater's top and snap into position. Then insert the two (2) sheet metal screws provided into the same holes to secure legs down into place (see **Figure 7b**).

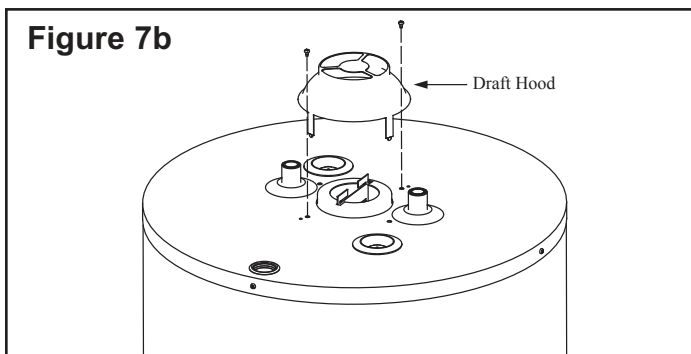

Venting System

The venting system must be attached to the draft hood to connect the water heater to the gas vent or chimney. The vent pipe connecting to the water heater must be of the same size as the draft hood. It is highly recommended to install this water heater on a separate venting system from other appliances. In some installations, proper venting may require the use of a larger diameter vent pipe and/or combined venting with other appliances. Consult the vent tables in the CSA B149.1 in Canada

and/or the National Fuel Gas Code, ANSI Z223.1 in the United States to correctly size the vent pipe.

When connecting the vent pipe to the water heater the following instructions must be followed:

- Install the vent pipe in such a way as to avoid any unnecessary bends that could create resistance to the flow of combustion gases.
- The horizontal length of the vent pipe must not exceed 75% of the vertical vent height. In no case shall it exceed twenty (20) feet (6.1 m) horizontally.
- All horizontal runs must have a minimum rise of 1/4 inch per foot (21 mm/m) of run (See **Figure 8**).
- All joints must be securely fastened with sheet metal screws or other approved means.
- All single wall vent piping must maintain a minimum of six (6) inches (15.2 cm) of clearance from combustible materials.
- Venting systems made with single wall piping cannot pass through any attic, inside wall, crawlspace, confined space, or any floor.
- The vent piping must be accessible for inspection, cleaning, and replacement.

⚠ WARNING

When the installation is complete, visually inspect the venting system to make sure that all joints are properly connected and all instructions have been followed. Failure to properly install the venting system could result in property damage, personal injury, or death.

Water Piping

Refer to **Figure 8** for a typical installation. Use of this layout should provide a trouble-free installation for the life of the water heater. Before making the plumbing connections, locate the **COLD** water inlet and the **HOT** water outlet. These fittings are both 3/4" NPT male thread. Make sure that the dip tube is installed in the cold water inlet. Install a shut-off valve close to the water heater in the cold water line. It is recommended that unions be installed in the cold and hot water lines so that the water heater can be easily disconnected, if servicing is required.

When assembling the hot and cold water heater pipings, use Teflon™ tape or a good food grade of pipe joint compound, and ensure all fittings are tight. It is imperative that open flame is not applied to the inlet and outlet fittings, as heat will damage or destroy the plastic lined fittings. **This will result in premature failure of the fittings, which is not covered by the warranty.**

INSTALLATION INSTRUCTIONS

Temperature and Pressure-Relief Valve

⚠ WARNING

DO NOT plug the temperature and pressure-relief valve or its discharge line. **DO NOT** remove the relief valve. Make sure the relief valve is properly sized for the water heater. If the relief valve continuously discharges water, call **Enercare Home Services** at **1-800-266-3939** to correct the problem. Failure to follow these instructions can result in property damage, personal injury, or death.

To protect from excessive pressure and/or temperature, the manufacturer has installed a temperature and pressure-relief valve that meets the requirements of the Standard for Relief Valves and Automatic Gas Shut-Off Devices for Hot Water Supply Systems, CSA 4.4 in Canada and ANSI Z21.22 in the United States. This relief valve has a maximum set pressure that does not exceed the hydrostatic working pressure of the water heater (150 psi = 1,035 kPa) and a Btuh rating equal to or greater than the input rating, as shown on the water heater rating plate. It should never be plugged or removed from the opening marked for it on the water heater.

Should this relief valve need to be replaced, use only a new temperature and pressure-relief valve. Never install an old or existing relief valve as it may be damaged or inadequate for the working requirements of the new water heater. This new relief valve must meet all local codes or, at a minimum, the requirements listed above. Never install any other type of valve between the relief valve and the water heater.

A discharge line must be installed into the relief valve. The discharge line:

- Must not be smaller than the outlet pipe size of the relief valve.
- Must not terminate less than six (6) inches (15.2 cm) and not more than twelve (12) inches (30.5 cm) above the floor.
- Must not be restricted in any way. Do not thread, cap, or in any way restrict the end of this outlet.
- Must be of a material capable of withstanding 210°F (99°C) without distortion.
- Must be installed to allow complete drainage of the relief valve and discharge line.
- Must discharge to a suitable place for disposal when relief occurs (not subject to freezing).

Figure 8

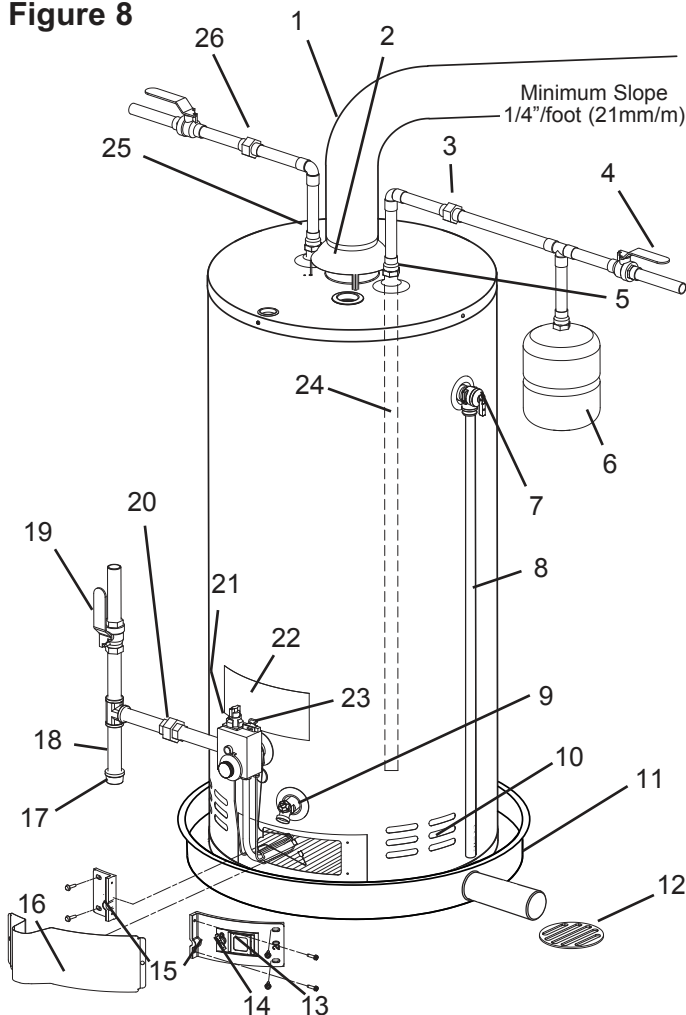

- | | |
|--|--------------------------------------|
| 1) Vent pipe | 16) Outer access door |
| 2) Draft hood | 17) Cap |
| 3) Union | 18) Drip leg (Sediment trap) |
| 4) Cold water manual shut-off valve | 19) Gas supply manual shut-off valve |
| 5) Cold water inlet | 20) Union |
| 6) Expansion tank | 21) Gas control |
| 7) Temperature & pressure-relief valve | 22) Rating plate |
| 8) Overflow tube | 23) Piezo igniter |
| 9) Drain valve | 24) Dip tube |
| 10) Combustion air intake holes | 25) Hot water outlet |
| 11) Drain pan | 26) Union |
| 12) Free-flowing floor drain | 27) Burner |
| 13) Sight glass | 28) Main burner orifice |
| 14) Resettable thermal switch | 29) Pilot |
| 15) Inner access door | 30) Thermocouple |
| | 31) Electrode |
| | 32) Manifold Spring (on some models) |

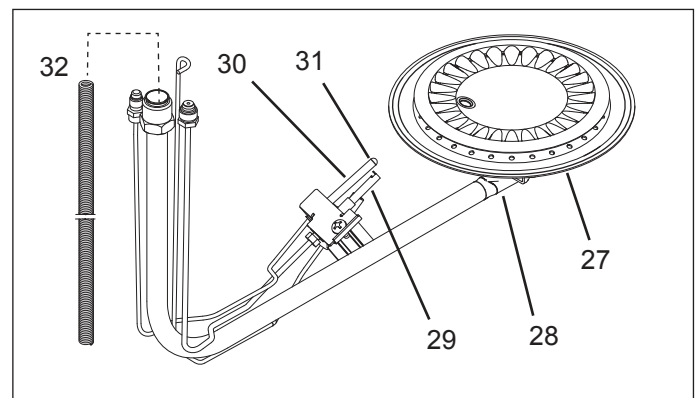

INSTALLATION INSTRUCTIONS

Pressure Build-up in a Water System

When the water heater operates, the heated water expands creating a pressure build-up. This is a natural function and is one of the reasons for installing a temperature and pressure-relief valve. If the cold water supply line has a built-in water meter, check valve, or pressure-reducing valve, a suitable expansion tank must be installed to prevent pressure build-up or water hammer effect, otherwise the warranty is void (see Figure 8). An indication of pressure build-up is frequent discharges of water from the relief valve. If the relief valve discharges water on a continuous basis, it may indicate a malfunction of the relief valve. Call Enercare Home Services at: 1-800-266-3939. If the relief valve is not defective the service call may be at the cost of the consumer.

Filling the Water Heater

WARNING

NEVER operate the water heater unless it is completely filled with water. **Failure to follow this instruction can result in premature failure of the water heater that is not covered by the warranty.**

Check that all of the water piping connections have been made. To fill the water heater:

- 1) Make sure that the water heater drain valve is closed by inserting a flat-head screwdriver into the slot on the head of the drain valve and turning the knob clockwise .
- 2) Open the cold water supply manual shut-off valve. This valve must remain open as long as the water heater is in use. Never operate the water heater with the cold water supply manual shut-off valve closed.
- 3) To make sure the water heater is completely full of water, open hot water faucets to let the air out of the water heater and plumbing system. Leave the faucets open until a constant flow of water is obtained.
- 4) Check all of the plumbing connections to make sure there are no leaks.

Gas Connections

WARNING

DO NOT attempt to use this water heater with any gas other than the type of gas shown on the water heater rating plate. Failure to follow this instruction can result in property damage, personal injury, or death.

The gas piping must be installed as indicated in **Figure 8**. For the correct size of piping for this water heater, consult CSA B149.1 in Canada and/or the National Fuel Gas Code, ANSI Z223.1

in the United States and local codes. Only new piping with cleanly cut threads may be used, together with a suitable sealing compound that is approved for natural gas and propane. It is mandatory that a readily accessible manual shut-off valve be installed in the gas supply line. The gas supply manual shut-off valve must be close to the water heater. A drip leg (sediment trap) must be installed in the gas line ahead of the gas control to prevent dirt from entering it. A union must be installed between the gas control and the gas supply manual shut-off valve for easy maintenance of the water heater.

WARNING

NEVER use an open flame to test for gas leaks. A fire or explosion could occur resulting in property damage, personal injury, or death.

The water heater and its gas connection must be leak tested before placing the appliance into operation. To leak test the system:

- 1) Turn on the manual gas shut-off valve.
- 2) Use a soapy water solution to test all connections and fittings for leaks. Bubbles indicate a gas leak.
- 3) Correct all leaks.

Make sure that the inlet pressure to the water heater does not exceed fourteen (14) inches in W.C. (water column) for both natural and propane gases. Pressures in excess of 1/2 pound per square inch (3.5 kPa) can damage the gas control, resulting in a fire or explosion from leaking gas. For purposes of adjustment, the minimum inlet pressure is indicated on the water heater rating plate.

If any pressure testing of the gas line is undertaken at test pressures in excess of 1/2 psig (3.5 kPa), the water heater and its gas supply manual shut-off valve must be disconnected from the gas supply piping system, and the end of the pipe sealed with a female cap. If the testing is to be undertaken at a test pressure less than 1/2 psig (3.5 kPa), the gas supply manual shut-off valve must be closed. All testing must be done according to CSA B149.1 in Canada and/or the National Fuel Gas Code, ANSI Z223.1 in the United States and local codes.

WARNING

A high altitude orifice **MUST BE** installed for water heaters operating above 2,000 feet (609.6 m) of altitude. Failure to follow this instruction can result in property damage, personal injury, or death.

INSTALLATION INSTRUCTIONS

Installation Instructions for Water Heaters Approved for Space Heating & Potable Water Heating

A water heater cannot be used for space heating only. When using a water heater for space and potable water heating, the instructions provided in this manual and with the air-handling unit must be respected and, in **particular** the following:

- 1) All piping and components that are used in the system must be of a nonferrous type and suitable for potable water. This also applies to any sealant used.
- 2) When used as a dual purpose water heater, it must not be connected to any system that has been previously used for non potable water heating. This includes any piping because, in all probability, existing piping would have been, in the past, treated with chemicals for cleaning or sealing the system.
- 3) If this water heater is to be used for space heating, make sure that all safety codes are respected. Pay special attention to safety valve pressure and expansion tanks.
- 4) Do not use toxic chemicals to clean the potable water heating system.

- 5) Where water temperature in excess of 140°F (60°C) is required for a space heating application, a mixing valve must be installed in the potable side of the system. This will temper the water and reduce the risk of scalding.
- 6) If the incoming water line to the heater is equipped with a check valve, water meter, or pressure-reducing valve, an expansion tank must be installed in the system. This will prevent weeping from the water heater relief valve and premature failure of the heater due to expansion of the water during the heating cycle.
- 7) Before acquisition of a water heater for space heating application, it is necessary to have the area of intended use sized by Enercare. This will ensure that an adequate water heating capacity will be available for both heating and potable water supply, and that the application will meet all local codes and public utility requirements.

Note: It is good practice to oversize the water heater, to ensure that all of the potential hot water requirements are available. Always refer to local plumbing codes for proper installation.

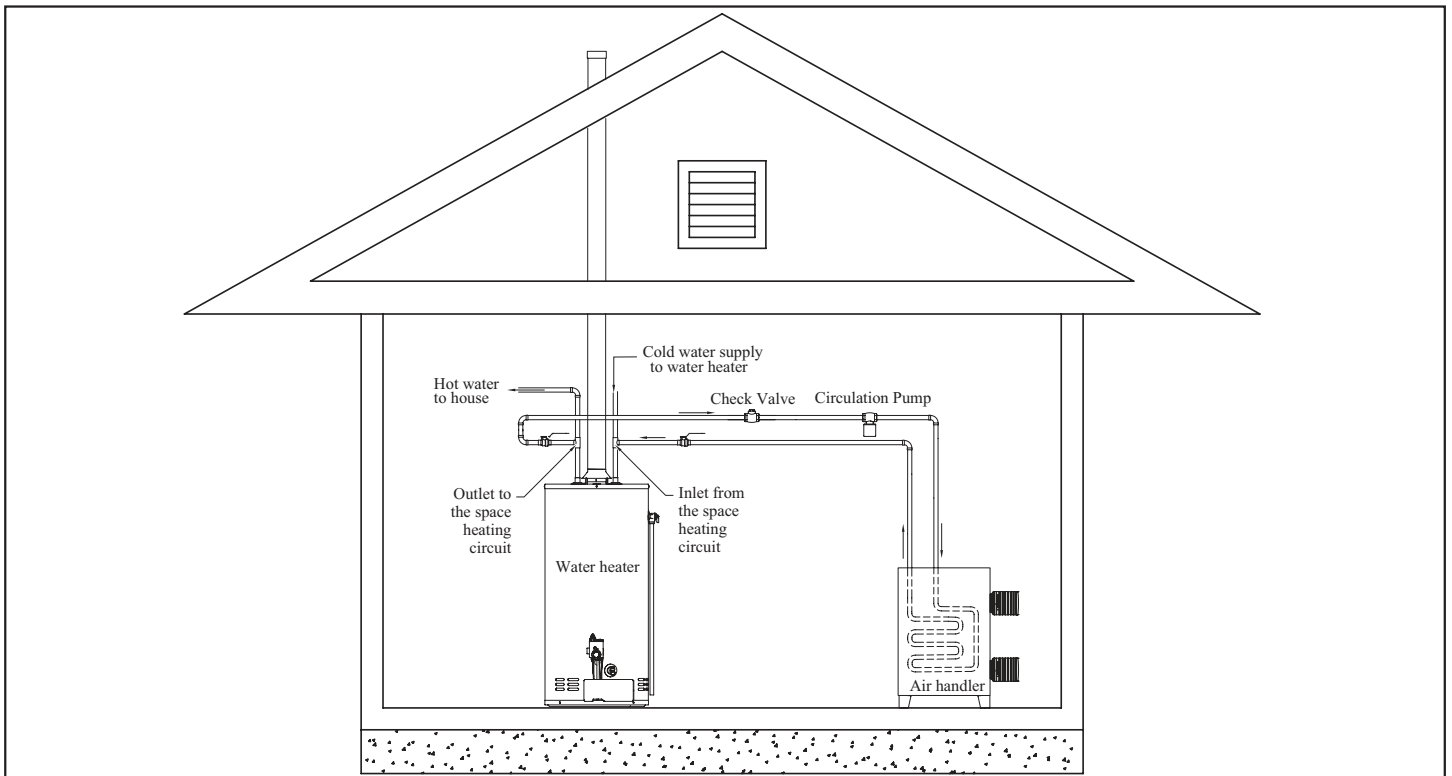

Installation Checklist

Refer to the Enercare Home Services checklist

OPERATING INSTRUCTIONS

Lighting the Water Heater



Lighting or re-lighting your water heater will be done by Enercare Home Services. For any problems occurring after installation please contact: Enercare Home Services at 1-800-266-3939.

WARNING

DO NOT light this water heater if:

- It is not full of water.
 - The gas supplied does not match the type listed on the rating plate.
 - The sight glass or burner access door gasket has been damaged or broken.
 - Gasoline or other flammable vapours and liquids have been stored in the vicinity of the water heater.
- Failure to follow these instructions can result in property damage, personal injury, or death.

FOR YOUR SAFETY, READ BEFORE LIGHTING

WARNING: If you do not follow these instructions exactly, a fire or explosion may result causing property damage, personal injury, or death.

- A. This appliance has a pilot which must be lit by a piezo-electric spark gas ignition system. **DO NOT** open the inner door and attempt to light the pilot by hand.
- B. **BEFORE LIGHTING**, smell all around the appliance area for gas. Be sure to smell next to the floor because some gases are heavier than air and will settle on the floor.

WHAT TO DO IF YOU SMELL GAS:

- **DO NOT** try to light any appliance.
- **DO NOT** touch any electric switch.
- **DO NOT** use any phone in your building.
- From a neighbour's phone, immediately call your gas supplier. Follow the gas supplier's instructions.

- If you cannot reach your gas supplier, call the fire department.

- C. Use only your hand to push in or turn the gas control knob. Never use tools. If the knob will not push in or turn by hand, do not try to repair it. Call a qualified service technician. Force or attempted repair may result in a fire or explosion.
- D. **DO NOT** use this water heater if any part has been under water. Immediately call a qualified service technician to inspect the water heater and to replace any part of the control system and any gas control which has been under water.

LIGHTING INSTRUCTIONS

1. **STOP!** Read the safety information above on this label.
2. Turn the temperature dial clockwise to the "PILOT LIGHTING" position.
3. Depress slightly and turn the gas control knob clockwise to the "OFF" position.

Gas control knob shown in "OFF" position

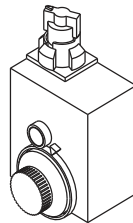

Note: The gas control knob cannot be turned from "PILOT" to "OFF" unless the knob is depressed slightly. Do not force.

4. Wait five (5) minutes to clear out any gas. Then smell for gas, including near the floor. If you smell gas, **STOP!** Follow "B" in the safety information above (to the left) on this label. If you don't smell gas, go to the next step.
5. Remove the outer access door.
6. Locate the piezo igniter button.
7. Look into the sight-glass window on the inner access door to view the pilot.

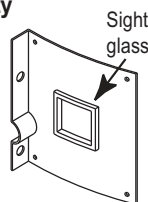

8. Turn the gas control knob counterclockwise to the "PILOT" position.
9. Depress and hold down the gas control knob. Immediately depress the piezo igniter button until you hear a "click" sound, then release. Continue to hold down the gas control knob for approximately one (1) minute after the pilot is lit. If the pilot does not light, continue to depress and release the piezo igniter button. Release the gas control knob, and it should pop back up. The pilot should remain lit. If it goes out, repeat steps 3 through 8.
 - If the knob does not pop up when you release it, stop and immediately call a qualified service technician or gas supplier.
 - If the pilot will not stay lit after several tries, turn the gas control knob clockwise to the "OFF" position and call a qualified service technician or the gas supplier.
10. Replace the outer access door.
11. Turn the gas control knob counterclockwise to the "ON" position.
12. Turn the temperature dial to the desired setting.

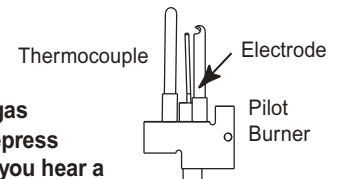

TO TURN OFF GAS TO APPLIANCE

1. Turn the temperature dial clockwise to the "PILOT LIGHTING" position.
2. Depress slightly and turn the gas control knob clockwise to the "OFF" position.

OPERATING INSTRUCTIONS

Draft Hood Operation

It is important to check that the ventilation system is working properly once the water heater main burner has been lit. Wait ten (10) minutes after lighting the burner. Then introduce a match or candle around the opening of the draft hood. If the flame is drawn towards the opening, this indicates proper ventilation. If the flame flutters or is blown out, combustion gases are escaping from the draft hood opening. If this occurs, shut the water heater off immediately and locate the problem. Do not try and operate the water heater again until you are satisfied that the problem has been corrected.

Water Temperature Regulation

⚠ WARNING

The higher the setting, the greater the risk of scalding. Hot water can cause third degree burns in under one (1) second at 160°F (71°C), in five (5) seconds at 140°F (60°C), and in thirty (30) seconds at 130°F (54°C). In households where there are children, physically challenged individuals, or elderly persons, mixing valves for point of use are necessary as means of reducing the scalding potential of hot water.



The gas control is factory-adjusted to its lowest temperature. The desired water temperature can be selected by rotating the temperature dial on the front of the gas control. Turn the temperature dial clockwise  to decrease the temperature, or counterclockwise  to increase the temperature. The reference mark on the temperature dial, indicated by a large triangle, represents 130°F (54°C) (see Figure 9). Each mark to the left and right of this reference mark indicates a temperature change of approximately 10°F (6°C).

Figure 9



When hot water is drawn from the tank in frequent short bursts, a condition known as “stacking” is created. “Stacking” is the result of increased cycling of the burner and can produce very hot water temperatures at the hot water outlet. Always remember to check the hot water coming out of any faucet with your hand before usage. This will reduce the risk of scalding-related injury. Still be carefull before introducing your hand in the hot water.

The gas control is equipped with a high limit switch (H.L.S.). Should the temperature of the water exceed 195°F (90°C), the H.L.S. will shut off the gas to the water heater. If the H.L.S. has tripped, the gas control must be replaced by Enercare Home Services.

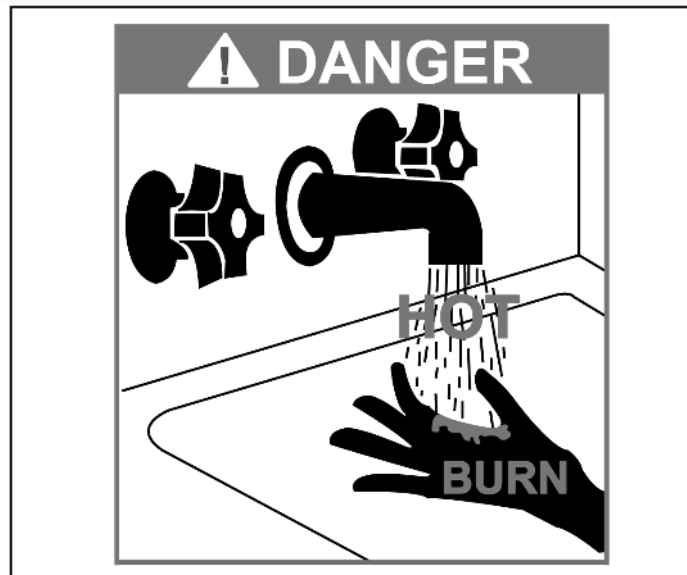
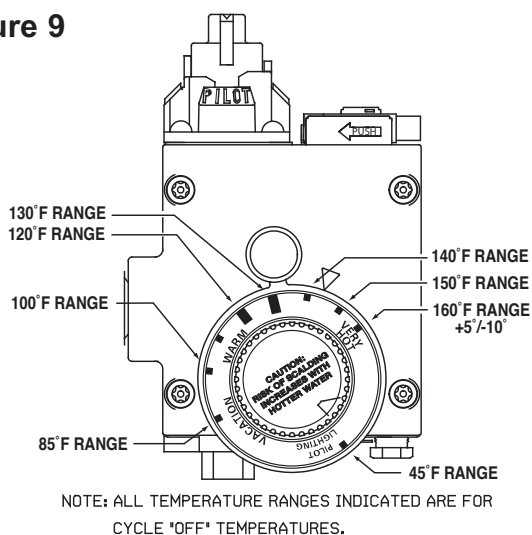
⚠ WARNING

Should overheating occur or the gas supply fail to shut off, close the gas supply manual shut-off valve. Failure to follow this instruction can result in property damage, personal injury, or death.

If the water heater has been subjected to fire, flood, or been damaged in any way, close the gas supply manual shut-off valve. Do not operate the water heater again until it has been inspected by Enercare Home Services.

Out of Fuel

If your water heater should run out of gas, proceed as follows:

- 1) Close the gas supply manual shut-off valve.
- 2) Depress slightly and turn the gas control knob clockwise  to the “OFF” position.
- 3) Once the gas supply has been re-established, proceed to the **Lighting Instructions**.

GENERAL MAINTENANCE

Housekeeping

WARNING

DO NOT store or use gasoline or other flammable vapours and liquids around the water heater.

DO NOT block or, in any way, restrict the flow of fresh air through the combustion air intake holes at the bottom of the water heater.

DO NOT put or store any objects on the top of the water heater.

Failure to follow these instructions can result in property damage, personal injury, or death.

Keep the area around the water heater clean and free of dust, lint, and dirt. It is the responsibility of the home owner to do so in order to prevent any malfunction that is not Enercare's responsibility. Verify the combustion air intake holes, at the bottom of the water heater, at least once every six (6) months and vacuum up any dirt, as required. Make sure that all of the minimum clearances to combustible materials are being maintained.

Condensation

As moisture from the products of combustion comes into contact with the cold surface of the inner tank, it may condense. This situation will usually occur:

- 1) when the water heater is filled for the first time;
- 2) if the water heater has been undersized;
- 3) when large amounts of hot water are drawn from the water heater in a short period of time and the refill water is very cold.

Due to the high-efficiency rating of this gas-fired water heater, it may produce more condensation than older models. Condensation forming on the flue tube will drop on the burner making a "sizzling" sound. In extreme cases, the condensate may even extinguish the pilot flame. This condition is not uncommon and must never be misinterpreted as a leaking tank. It will disappear once the water becomes heated.

Main Burner & Pilot

In order to maintain the efficiency of the water heater, the consumer should inspect the flame of the main burner pilot. Remove the outer access door and look through the sight glass to examine the flames. A soft blue flame indicates proper gas combustion. A yellow tipped flame indicates poor combustion. If so, with a vacuum cleaner, remove any dust, lint, and dirt accumulation around the water heater and in the combustion air intake holes. If the poor combustion persists and there is no lint around the water heater

call Enercare Home Services at 1-800-266-3939. This service call may be at the expense of the consumer if lint is blocking the flame arrestor plate.

WARNING

DO NOT remove the inner access door at any time. If the combustion chamber must be accessed to clean the burner assembly or flame arrestor grille, call Enercare Home Services at 1-800-266-3939. This service call is at the expense of the consumer. Failure to follow these instructions can result in property damage, personal injury, or death.

Draining the Water Heater

You may choose to drain the tank at your convenience in very hard water conditions.

Temperature and Pressure-Relief Valve

On a regular basis, visually inspect the valve for any leakage, if so call Enercare Home Services at 1-800-266-3939.

Venting System Inspection

The venting system must be visually inspected once a year by the homeowner. Check the area where the water heater is located to make sure that there is enough clean combustion and ventilation air. Remove any possible obstructions that would prevent proper air circulation and venting. Check the venting system to make sure that all of the connections are securely fastened, and that all of the joints are properly sealed. If any part of the venting system is damaged, it must be replaced by Enercare Home Services at 1-800-266-3939. Test the venting system to make sure that it is working properly (**refer to the *Draft Hood Operation* section of this manual**).

Anodes

This water heater is equipped with two (2) anodes that are designed to prolong the life of the glass-lined tank. The anodes are slowly consumed, protecting the glass-lined tank from corrosion. If you get a rotten egg smell call Enercare Home Services at 1-800-266-3939. We may have a solution to your water condition problem (See the explanation of rotten eggs below).

The life expectancy of the water heater is reduced where a water softener is introduced to fight hard water, because the sodium salts added by a softener make this water extremely conductive. In these conditions, the anodes are consumed more rapidly.

Please advise Enercare that you operate a water softener so they can take the proper precaution.

GENERAL MAINTENANCE

In certain water conditions, the anodes will react with the water, producing discoloured or smelly water. The most common complaint is hot water that smells like rotten eggs. This phenomenon is the result of the reaction between the anodes and hydrogen sulfide gas dissolved in the water which occurs frequently in well systems. This problem can usually be eliminated or reduced by changing the anodes to a type more suitable for these conditions (aluminum anodes) and by chlorinating the water heater and plumbing system. If the problem persists, special filtration equipment may be required. Under no circumstances are the anodes to be removed from the water heater on a permanent basis. **Removal of the anodes will lead to premature failure of the water heater and void the warranty.**



This is not an Enercare Home Services issue but a consumer issue in his water supply and the consumer is responsible for any apparatus needed to remove the rotten egg smell.

WARNING

Hydrogen gas can be produced in a hot water system that has not been used for a long period of time (generally two (2) weeks or more). **HYDROGEN GAS IS EXTREMELY FLAMMABLE.** It is highly recommended to open the hot water faucet in the kitchen for several minutes before you use any electrical appliances connected to the hot water system, such as a dishwasher or washing machine. If hydrogen gas is present, there will be an unusual sound, such as air escaping through the pipe, as the hot water faucet is opened. **DO NOT** smoke or introduce an open flame near the faucet when it is opened.

Draining the Water Heater

To completely drain the water heater:

- 1) Turn the temperature dial clockwise  to the "Pilot Lighting" position.
- 2) Depress slightly and turn the gas control knob clockwise  to the "OFF" position.
- 3) Close the gas supply manual shut-off valve.
- 4) Close the cold water supply manual shut-off valve.
- 5) Connect one end of a garden hose to the water heater drain valve and put the other next to a free-flowing drain.
- 6) Open the drain valve by inserting a flat-head screwdriver into the slot on the head of the drain valve and turning the knob counterclockwise .
- 7) Open a hot water faucet to allow air into the system.

Vacation

If you are planning a vacation or other prolonged absence, it is highly recommended to shut off the gas supply and the cold water supply to the water heater. This will save energy, protect against property damage in the event the water heater leaks, and prevent the build-up of hydrogen gas. If the water heater and piping are exposed to freezing temperatures, they should both be drained.

Remember to check the water heater thoroughly after it has been shut off for an extended period of time before putting it back in operation. Make sure that the water heater is completely full of water and that the cold water supply manual shut-off valve is open before lighting the burner.

Service Procedure

If you are having problems with your water heater, please call Enercare Home Services at 1-800-266-3939. Have handy the following:

- a) Name.
- b) Address.
- c) Contract number.
- d) Telephone number.
- e) Other people to reach in case of emergency.
- f) A description of the problem.

REPLACEMENT PARTS

Water Heater Assembly

- 1) Hot water outlet
- 2) Top pan
- 3) Piezo ignitor
- 4) Gas control
- 5) Outer access door
- 6) Drain valve
- 7) Overflow tube
- 8) Baffle
- 9) Flue reducer
- 10) Draft hood
- 11) Anodes
- 12) Dip tube
- 13) Temperature & pressure-relief valve

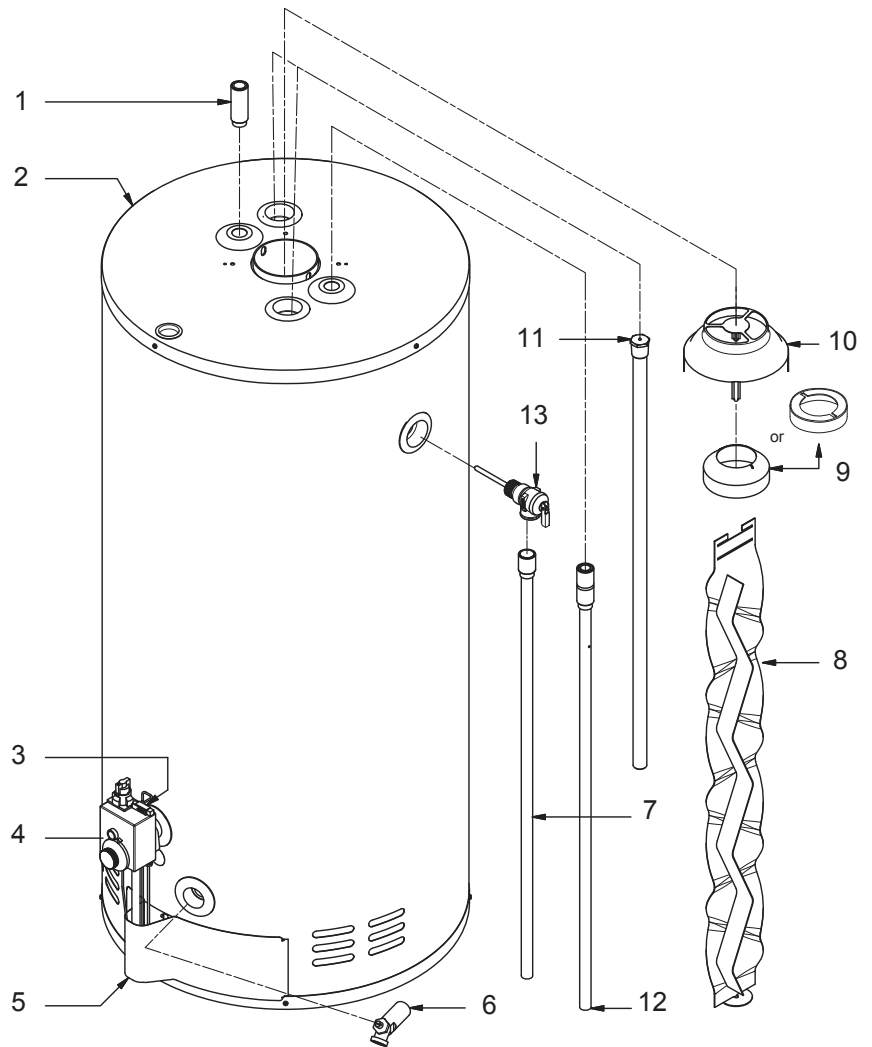

Burner Assembly

- 1) Manifold Spring (on some models)
- 2) Manifold
- 3) Inner Left Door
- 4) Access Door
- 5) Thermal High Limit Switch
- 6) Sight Glass
- 7) Inner Right Door
- 8) Pilot Orifice
- 9) Pilot Assembly
- 10) Burner Orifice
- 11) Burner

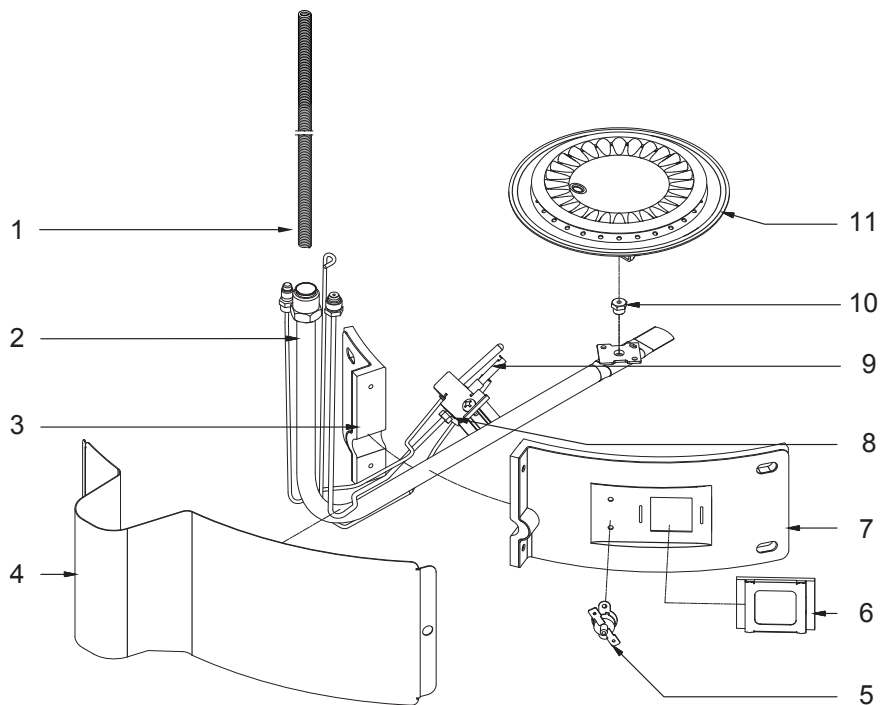

TROUBLESHOOTING GUIDE

Only Enercare Home Services personnel can service your rental water heater,
call 1-800-266-3939 for service.

CONDITION	CAUSE	CORRECTIVE ACTION
The burner will not ignite.	No gas.	Check with gas utility company.
	Dirt in gas line.	Notify utility. Install drip leg in gas line.
	Pilot line clogged.	Clean. Check for source of trouble and correct.
	Combustion air intake holes blocked.	With a vacuum cleaner, remove dirt, dust, and lint.
	Flame arrestor openings blocked.	With a vacuum cleaner, remove dirt, dust, and lint.
	Main burner line clogged.	Clean. Check for source of trouble and correct.
	Defective thermocouple.	Replace with new thermocouple.
	Defective gas control.	Replace with new gas control.
The burner flame floats and lifts off ports.	Gas control set too low.	Turn temperature dial to desired temperature.
	Heater installed in a confined area.	Provide fresh air ventilation.
	High gas pressure.	Check with gas utility company.
	Orifice too large.	Replace with correct orifice.
	Flue clogged.	Clean. Check for source of trouble and correct.
	Combustion air intake holes blocked.	With a vacuum cleaner, remove dirt, dust, and lint.
	Flame arrestor openings blocked.	With a vacuum cleaner, remove dirt, dust, and lint.
	Heater installed in a confined area.	Provide fresh air ventilation.
The burner flame is yellow and lazy.	Cold drafts (downdraft).	Locate source and correct.
	Insufficient secondary air.	Provide fresh air ventilation.
	Flue clogged.	Clean. Check for source of trouble and correct.
	Combustion air intake holes blocked.	With a vacuum cleaner, remove dirt, dust, and lint.
	Flame arrestor openings blocked.	With a vacuum cleaner, remove dirt, dust, and lint.
	Main burner line clogged.	Clean. Check for source of trouble and correct.
The burner flame is too high.	Heater installed in a confined area.	Provide fresh air ventilation.
	Insufficient secondary air.	Provide fresh air ventilation.
	Orifice too large.	Replace with correct orifice.
The flame burns at the orifice.	Defective gas control.	Replace with new gas control.
	Low gas pressure.	Check with gas utility company.
The pilot will not light or remain lit.	Defective gas control.	Replace with new gas control.
	No gas.	Check with gas utility company.
	Dirt in gas line.	Notify utility. Install drip leg in gas line.
	Pilot line clogged.	Clean. Check for source of trouble and correct.
	Loose thermocouple connection.	Tighten with fingers then take 1/4 turn with wrench.
	Defective thermocouple.	Replace with new thermocouple.
	Cold drafts (downdraft).	Check source and correct.
	Combustion air intake holes blocked.	With a vacuum cleaner, remove dirt, dust, and lint.
	Flame arrestor openings blocked.	With a vacuum cleaner, remove dirt, dust, and lint.
	Gas control high limit switch has tripped.	Replace with new gas control.
	Resettable thermal switch on inner access door has tripped.	Reset thermal switch on inner access door and re-light burner.
	Flammable vapours incident.	Contact Enercare Home Services at 1-800-266-3939.
The access door temperature high limit switch is tripping.	Defective igniter.	Replace igniter assembly.
	Not enough draft from the chimney.	Check for any obstruction in the chimney. Ensure that the chimney is sized and installed according to proper installation codes.
	Not enough fresh air for the combustion.	Supply make-up air. Refer to the proper installation codes.
	Ambiant air temperature is too high.	Reduce ambient air temperature.
	Excessive dirt, dust or other debris accumulation on the flame arrestor.	Clean the flame arrestor in the combustion chamber using a stiff brush, compressed air and/or a vacuum cleaner.
High operating costs.	Gas control set too high.	Turn temperature dial to desired temperature.
	Sediment or lime in tank.	Drain. Check to see if water treatment is necessary.
	Water heater is undersized.	Install size of water heater that meets demand.
	Wrong piping connections.	Correct piping, dip tube must be in cold inlet.
	Leaking faucets.	Repair faucets.
	Gas leaks.	Check with gas utility company, fire department and Enercare Home Services at 1-800-266-3939

TROUBLESHOOTING GUIDE

Only Enercare Home Services personnel can service your rental water heater, call 1-800-266-3939 for service.

CONDITION	CAUSE	CORRECTIVE ACTION
High operating costs (Continued)	Wasted hot water.	Advise consumer.
	Long runs or exposed piping.	Insulate piping.
	Hot water piping on outside wall.	Insulate piping.
Insufficient hot water.	Low gas pressure.	Check with gas utility company.
	Wrong piping connections.	Correct piping, dip tube must be in cold inlet.
	Sediment or lime in tank.	Drain. Check to see if water treatment is necessary.
	Water heater is undersized.	Install the size of water heater that meets the demand.
	Gas control set too low.	Turn temperature knob to desired temperature.
	Leaking faucets.	Repair faucets.
	Wasted hot water.	Advise consumer.
	Long runs or exposed piping.	Insulate piping.
Slow hot water recovery.	Hot water piping on outside wall.	Insulate piping.
	Insufficient secondary air.	Provide fresh air ventilation.
	Low gas pressure.	Check with gas utility company.
	Gas control set too low.	Turn temperature dial to desired temperature.
	Improper calibration.	Replace gas control.
	Flue clogged.	Clean. Check for source of trouble and correct.
	Water heater is undersized.	Install size of water heater that meets demand.
	Wrong piping connection.	Correct piping, dip tube must be in cold inlet.
Leaking water.	Wasted hot water.	Advise consumer.
	Poorly sealed, hot or cold water connections, gas control threads, relief valve, or drain valve.	Tighten threaded connections.
	Leakage from plumbing system or other appliances.	Inspect plumbing system and other appliances.
Water drips from the relief valve.	Condensation.	Refer to Condensation .
	Heater stacking.	Lower gas control setting.
	Excessive water pressure.	Install a pressure-reducing valve.
	Thermal expansion in a closed water system.	Install an expansion tank.
The gas control fails to shut off.	Improperly seated valve.	Check relief valve works properly and replace if necessary.
	Defective gas control.	Replace with new gas control.
Condensation.	Improper calibration.	Replace gas control.
	Water heater filled for first time.	Let water heater warm up. Problem should go away. If it persists, check all plumbing connections for leaks.
	Heavy draws of hot water with very cold refill water.	Let water heater warm up. Problem should go away. If it persists, check all plumbing connections for leaks.
Combustion odours.	Water heater is undersized.	Install size of water heater that meets demand.
	Insufficient secondary air.	Provide fresh air ventilation.
	Heater installed in a confined area.	Provide fresh air ventilation.
Smoking and carbon	Flue clogged.	Clean. Check for source of trouble and correct.
	Insufficient secondary air.	Provide fresh air ventilation.
	Low gas pressure.	Check with gas utility company.
	Burner flame yellow, lazy.	Refer to The burner flame is yellow and lazy .
	Flue clogged.	Clean. Check for source of trouble and correct.
The pilot flame is too small.	Defective gas control.	Replace with new gas control.
	Heater installed in a confined area.	Provide fresh air ventilation.
	Low gas pressure.	Check with utility.
Smelly water.	Pilot line or orifice clogged.	Clean. Check for source of trouble and correct.
	High sulfate or mineral content in water.	Change magnesium anode to an aluminum anode and bleach tank.



enercare™

enercare.ca

™Enercare and the design are trademarks of Enercare Inc., used under license.