

COMMERCIAL ELECTRIC WATER HEATER, FLEXIBLE OWNER'S MANUAL INSTALLATION AND OPERATING INSTRUCTIONS

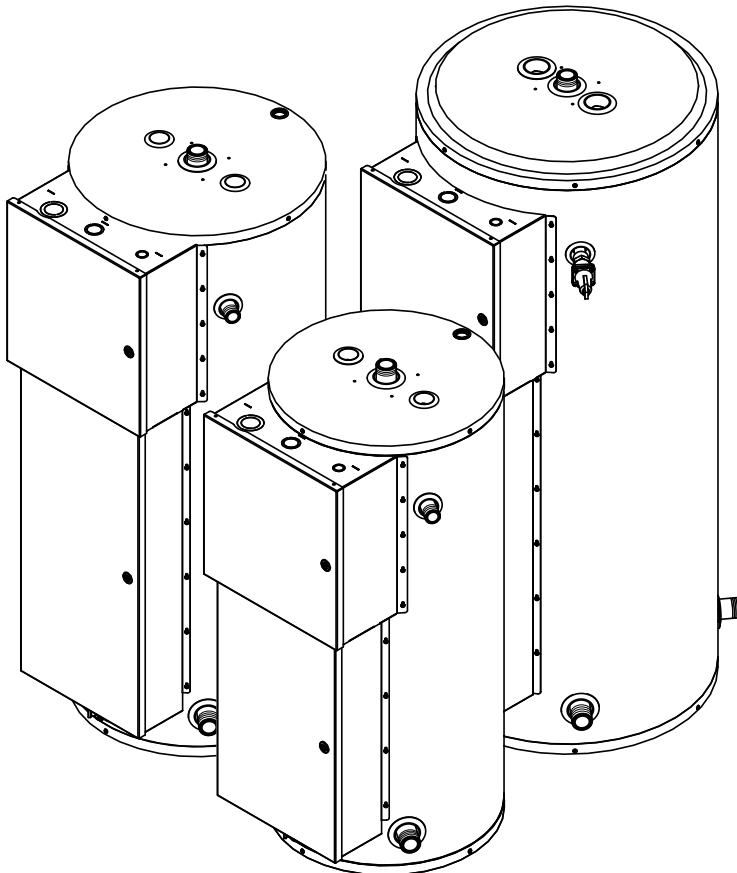

105-108-112 Models

⚠ WARNING

If the information in these instructions is not followed exactly, a fire or explosion may result causing property damage, personal injury, or death.

- **DO NOT** open the electrical junction box or the element access panel before the power to the water heater is turned "OFF".
- **DO NOT ATTEMPT** to repair or replace any of the electrical components installed on the water heater before the power to the water heater is turned "OFF".
- **DO NOT USE** the water heater on a voltage other than that specified on the water heater rating plate.
- **DO NOT CONNECT** the power supply wiring to anywhere other than the power distribution block in electrical junction box of the water heater.
- **DO NOT TURN ON** the power to the water heater unless it is completely filled with water.
- **DO NOT DRAIN** the water heater unless the power to the water heater has been turned "OFF".
- **DO NOT STORE** or use gasoline or other flammable vapours and liquids in the vicinity of this or any other appliance.

WHAT TO DO IF YOU SMELL SMOKE

- Immediately turn "OFF" the power to the water heater.
- If after turning "OFF" the power the smoke continues, call your local fire department.
- When the smoke has stopped, call a qualified service technician to identify and repair the problem.

IMPORTANT

READ THESE INSTRUCTIONS CAREFULLY BEFORE BEGINNING THE INSTALLATION. PROPER INSTALLATION WILL PROVIDE SAFE AND EFFICIENT SERVICE, AND AVOID NEEDLESS EXPENSE NOT COVERED BY THE WARRANTY. READ THE PRODUCT WARRANTY CONTAINED IN THIS MANUAL AND REMEMBER TO FILL OUT AND RETURN TO THE MANUFACTURER ALL RELEVANT WARRANTY CARDS AND CERTIFICATES. SHOULD YOU HAVE ANY QUESTIONS, PLEASE CONTACT YOUR LOCAL DEALER OR REFER TO THE **GETTING SERVICE FOR YOUR WATER HEATER** SECTION OF THIS MANUAL. **SAVE THIS MANUAL FOR FUTURE REFERENCES.**

For your records, write the model and serial number here:

Model # _____

Serial # _____



TABLE OF CONTENTS

Safety Information	2	Start-up Procedure	26
Installation Instructions	3	Safety Controls	26
Location	3	To reset the high limit switch	26
Water Piping	4	Water Temperature Regulation	26
Temperature & Pressure-Relief Valve	4	To adjust the temperature on the thermostat	26
Pressure Build-up in a Water System	5	General Maintenance	27
Filling the Water Heater	5	Clean Out Access	27
Electrical Connections	8	Element and Thermostat Replacement	27
Voltage	9	Temperature and Pressure-Relief Valve	27
Conversion Instructions	23	Anodes	27
Field Conversions	23	Draining the Water Heater	28
Phase Conversions	23	Vacation	28
Surface mount Thermostat	23	Getting Service for your Water Heater	28
Wattage & Voltage Conversion for 208V, 240V, 277V & 480V Models	24	Replacement Parts	29
Wattage & Voltage Conversion for 600V Models	24	Troubleshooting Guide	34
Operating Instructions	25	Warranty	36
Installation Checklist	25		
Starting the Water Heater	25		

SAFETY INFORMATION

Your safety and the safety of others is extremely important during the installation, operation, and servicing of this water heater. Many safety-related messages have been provided in this manual and on your water heater. Always read and abide by all safety messages. These messages will point out the potential hazard, tell you how to reduce the risk of injury, and tell you what will happen if the instructions are not followed.



This is the safety alert symbol. This symbol alerts you to potential hazards that can kill or hurt you and others. All safety messages will follow the safety alert symbol and either the word “**DANGER**” or “**WARNING**”.

 DANGER	Serious injury or death can occur if you do not follow the instructions immediately.
 WARNING	Serious injury or death can occur if you do not follow the instructions.

WARNING

DO NOT use this water heater if any part has been under water. Immediately call a qualified service technician to inspect the water heater and to replace any part of the control system which has been under water. Failure to follow this instruction can result in property damage, personal injury, or death.

IMPORTANT

These instructions have been written as a guide for the proper installation and operation of your water heater, and the manufacturer of this water heater will not accept any liability where these instructions have not been followed. However, for your safety and to avoid damage caused by improper installation, this water heater must be installed by a Certified Licensed Professional, and meet all local codes or, in the absence of local codes, CSA C22.1 Canadian Electrical Code, in Canada, and/or the National Electrical Code, ANSI/NFPA 70, in the United States.

Before proceeding with the installation instructions:

- 1)** Inspect the water heater and its component parts for possible damage. Do not install or attempt to repair any damaged component parts. If you detect any damage, contact the dealer where the water heater was purchased or the manufacturer listed on the warranty card.
- 2)** Verify that the voltage being supplied corresponds to that which is marked on the water heater rating plate.

INSTALLATION INSTRUCTIONS

Location

This water heater should be located as close as possible to an adequate power supply and to the main use of hot water. This location must not be subject to freezing temperatures. The water heater should be positioned so that the electrical junction box, element, and thermostat access panels can be opened for inspection, adjustment, and servicing of the elements, thermostats and other electrical components. The drain valve must also be accessible. The water heater must be located close to a suitable free-flowing floor drain. Where a floor drain is not adjacent to the water heater, a suitable drain pan must be installed under the water heater (see **Figure 2**). In Canada, according to the National Plumbing Code, this drain pan must be at least two (2) inches (5.1 cm) larger than the diameter of the water heater, and at least three (3) inches (7.6 cm) deep providing access to the drain valve. Always make sure to follow local codes as they may be more rigorous. This pan must be piped to

a suitable drain to prevent damage to property in the event of a water leak from the piping, the relief valve, or the water heater.

Sooner or later, all water heaters leak. The manufacturer, based on national building codes has given the necessary advice to prevent damage to the building. Under no circumstances is the manufacturer to be held liable for any water damage in connection with this water heater.

Suggested clearances for service purposes are a minimum of twelve (12) inches (30.5 cm) from the top and thirty (30) inches (76.2 cm) in front of the unit. Should this water heater be installed on carpeting, the carpeting must be protected by a wood or metal panel beneath the water heater. This panel must extend at least three (3) inches (7.6 cm) beyond the width and depth of the water heater. Should the water heater be installed in an alcove or closet, the entire floor area must be covered by the panel.

Figure 1

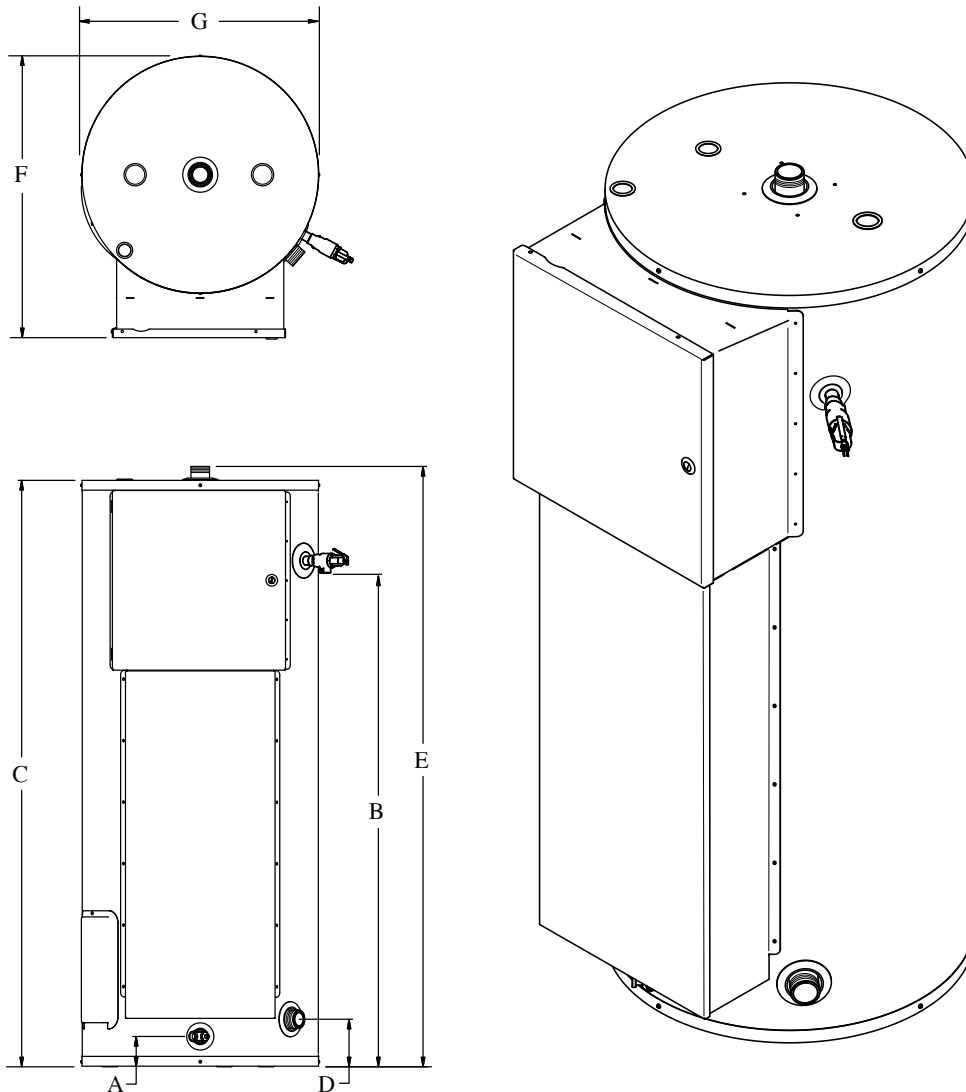

SPECIFICATIONS

Models	Storage Capacity		A Inches (cm)	B Inches (cm)	C Inches (cm)	D Inches (cm)	E Inches (cm)	F Inches (cm)	G Inches (cm)	
	Imp. gal.	L								Imp. gal.
105	49	184	41	3 1/8 (7.9)	40 1/4 (102)	49 1/8 (124.8)	4 7/8 (12.4)	50 5/8 (128.6)	26 1/4 (66.7)	22 (55.9)
108	74	279	61	3 1/8 (7.9)	51 3/8 (130.5)	59 5/8 (151.4)	4 7/8 (12.4)	62 (157.5)	28 1/4 (71.8)	24 (61)
112	119	451	99	4 1/8 (10.5)	56 5/8 (143.8)	67 3/8 (171.1)	6 1/8 (15.6)	69 1/4 (175.9)	32 5/8 (82.9)	28 1/4 (71.8)

INSTALLATION INSTRUCTIONS

Water Piping

Refer to **Figure 2** for a typical installation. Use of this layout should provide a trouble-free installation for the life of the water heater. Refer to **Figures 3 to 9** for different installation configurations. Before making the plumbing connections, locate the COLD water inlet and the HOT water outlet, these fittings are both 1½" N.P.T. male thread. Female NPT fittings must be used during the installation. Install a shut-off valves close to the water heater in the hot and cold water lines. It is recommended that unions be installed in the hot and cold water lines so that the water heater can be easily disconnected, if servicing is required.

When assembling the hot and cold piping to the water heater, use Teflon™ tape and wrap it clockwise around all the threads or a good food grade of pipe joint compound, and ensure all fittings are tight. **DO NOT HEAT THESE FITTINGS** when making welded connections to the water heater. Solder the pipe to a threaded connection before screwing it to the water heater fittings. It is imperative that open flame is not applied to the inlet and outlet fittings, as heat will damage or destroy the plastic lined fittings. **This will result in premature failure of the fittings, which is not covered by the warranty.**

Temperature and Pressure-Relief Valve

⚠ WARNING

DO NOT plug the temperature and pressure-relief valve or its discharge line. **DO NOT** remove the relief valve. Make sure the relief valve is properly sized for the water heater. If the relief valve continuously discharges water, call a qualified service technician to correct the problem. Failure to follow these instructions can result in property damage, personal injury, or death.

In order to provide full protection against excess pressure and/or temperature, a temperature & pressure-relief valve meeting the requirements of the Standard Relief Valves and Automatic Gas Shut-Off Devices for Hot Water Supply Systems, CSA 4.4, in Canada, and ANSI Z21.22, in the United States is supplied with the water heater and **MUST BE installed** by the installer. The relief valve should never be plugged or removed from the opening marked for it on the water heater.

If this relief valve should need to be replaced, use only a new temperature and pressure-relief valve. Never install an old or existing relief valve, as it may be damaged or inadequate for the working requirements of the new water heater. This new relief valve must meet all local codes and must have a maximum set pressure that does not exceed the hydrostatic working pressure of the water heater (150 psi = 1,035 kPa) and a BTU/hr rating equal to or greater than the input rating, as shown on the water heater rating plate. Never install another type of valve between the relief valve and the water heater.

A discharge line must be installed into the relief valve. The discharge line:

- Must not be smaller than the outlet pipe size of the relief valve.
- Must not terminate less than six (6) inches (15.2 cm) and not more than twelve (12) inches (30.5 cm) above a floor drain or drain pan connected to an adequate free-flowing drain.
- Must not be restricted in any way. Do not thread, cap, or in any way restrict the end of this outlet.
- Must be of a material capable of withstanding 210°F (99°C) without distortion.
- Must be installed to allow complete drainage of the relief valve and discharge line.

Figure 2

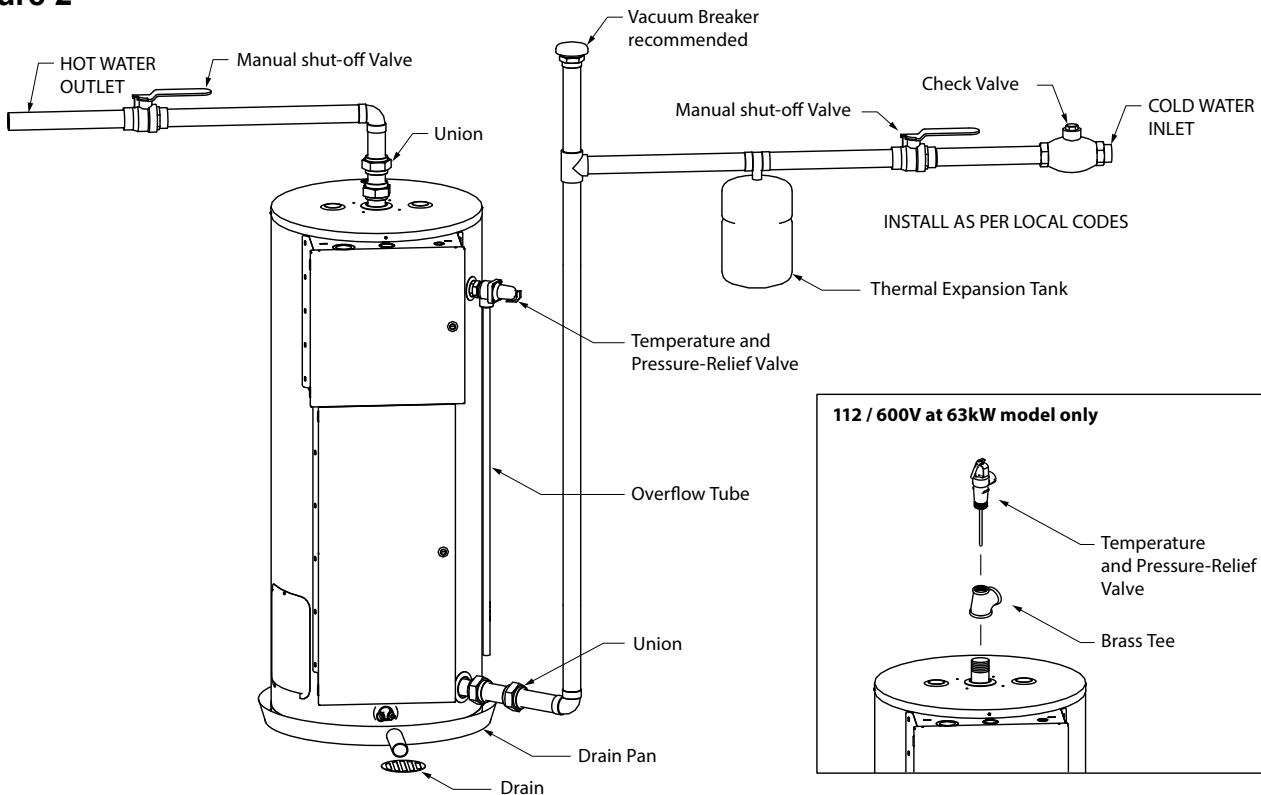

INSTALLATION INSTRUCTIONS

Pressure Build-up in a Water System

When the water heater operates, the heated water expands creating a pressure build-up. This is a natural function and is one of the reasons for installing a temperature and pressure-relief valve. If the cold water supply line has a check valve, a backflow prevention device or pressure-reducing valve, a suitable expansion tank (properly selected and calibrated) must be installed to prevent any undue expansion. The water distribution network must also be protected against water hammer by means of prefabricated rams. In the absence of these protections, the warranty is void (see Figure 2). An indication of pressure build-up is frequent discharges of water from the relief valve. If the relief valve discharges water on a continuous basis, it may indicate a malfunction of the relief valve, and a qualified service technician must be called to have the system checked, and the problem corrected.

Filling the Water Heater

⚠ WARNING

NEVER operate the water heater unless it is completely filled with water. Failure to follow this instruction can result in premature failure of the water heater and its component parts that is not covered by the warranty.

Check that all of the water piping connections have been made. To fill the water heater:

- 1) Make sure that the water heater drain valve is closed by inserting a flat-head screwdriver into the slot on the head of the drain valve and turning the knob clockwise ↻.
- 2) Open the cold water supply manual shut-off valve. This valve must remain open, as long as the water heater is in use. Never operate the water heater with the cold water supply manual shut-off valve closed.
- 3) To make sure the water heater is completely filled with water, open hot water faucets to let the air out of the water heater and plumbing system. Leave the faucets open until a constant flow of water is obtained.
- 4) Check all of the plumbing connections to make sure there are no leaks.

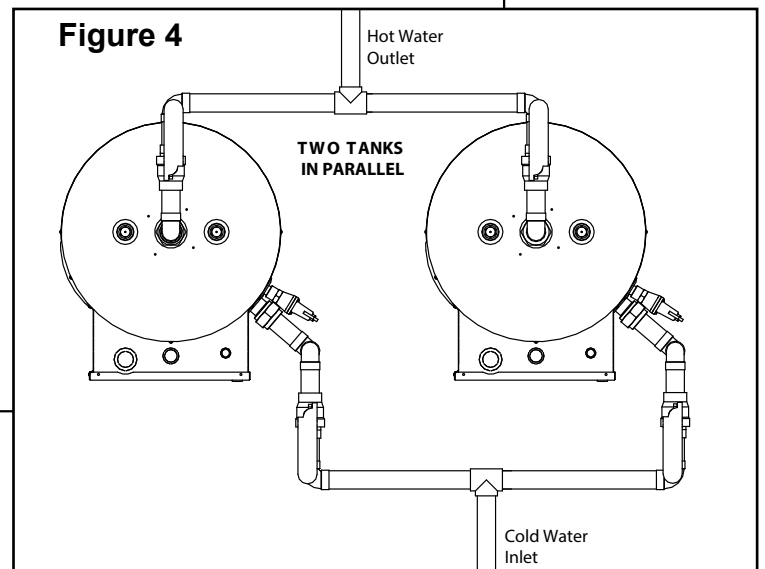
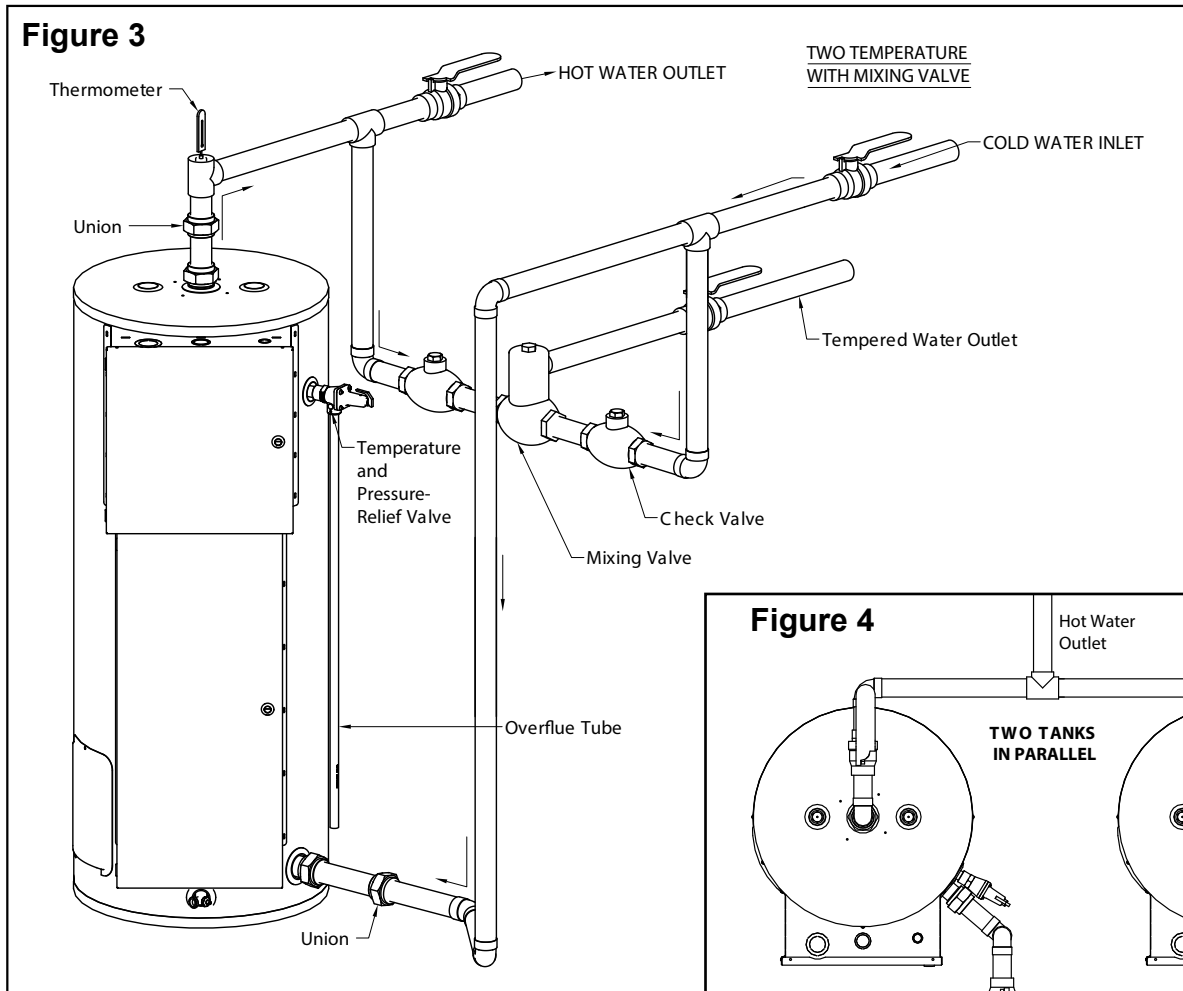

INSTALLATION INSTRUCTIONS

Figure 5

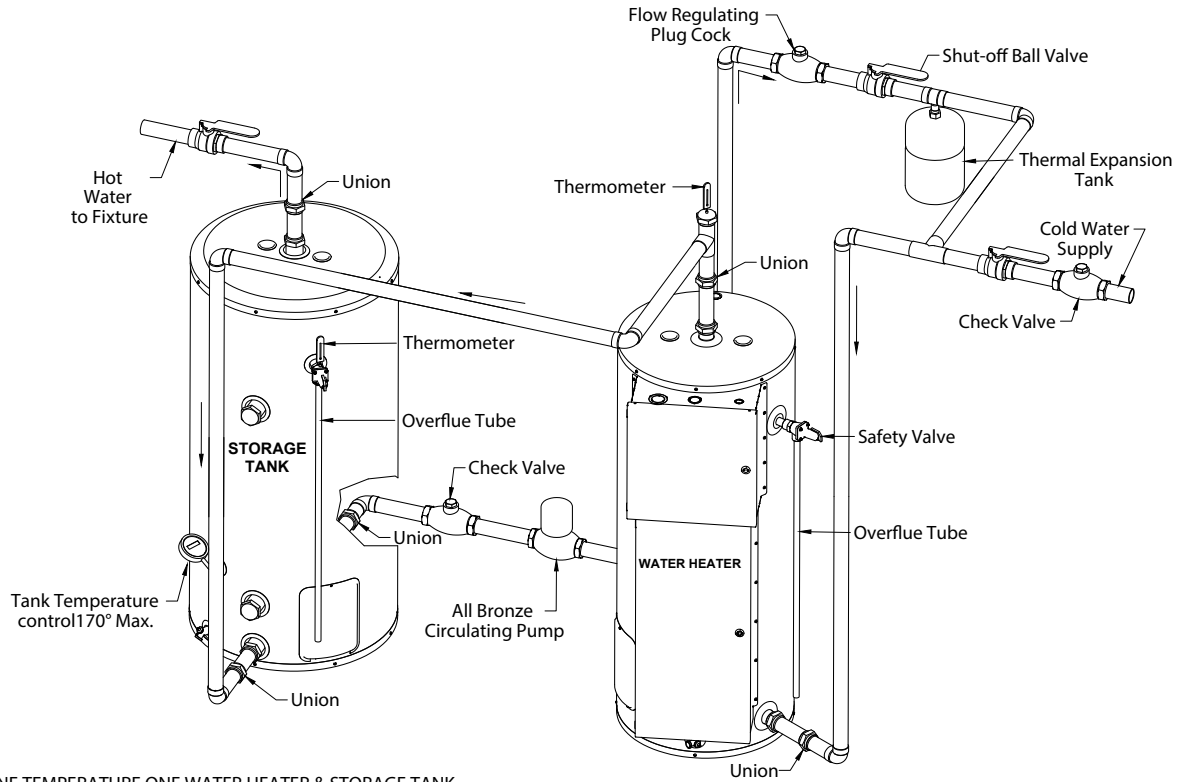

**ONE TEMPERATURE ONE WATER HEATER & STORAGE TANK
FORCED CIRCULATION WITHOUT BUILDING RECIRCULATION**

Figure 6

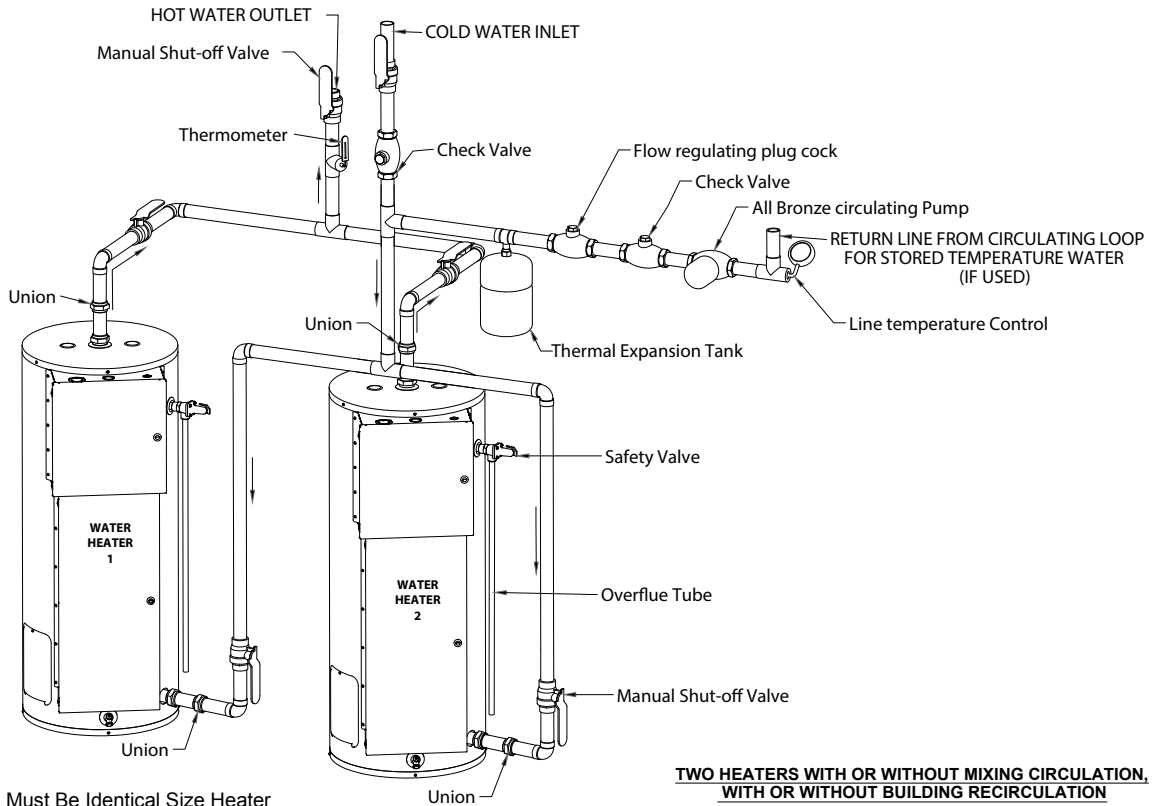

NOTE: Must Be Identical Size Heater

**TWO HEATERS WITH OR WITHOUT MIXING CIRCULATION,
WITH OR WITHOUT BUILDING RECIRCULATION**

INSTALLATION INSTRUCTIONS

Figure 9

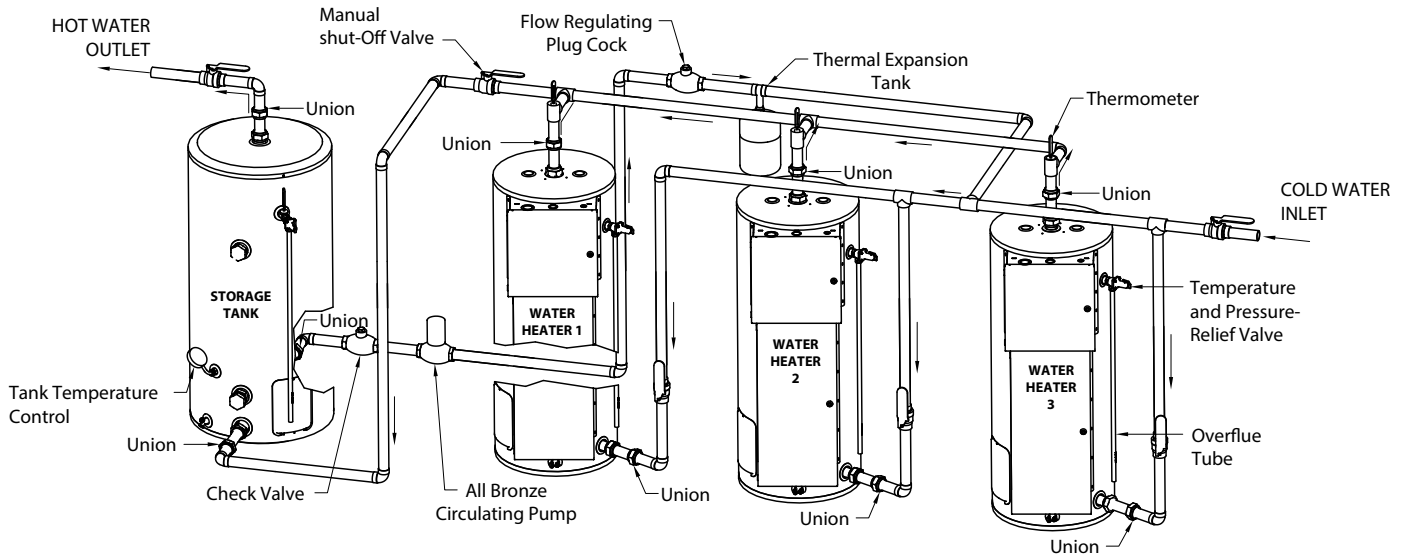

THREE WATER HEATERS WITH STORAGE TANK WITH OR WITHOUT BUILDING CIRCULATION

NOTE : Must Be Identical Power And Size Water Heaters

Electrical Connections

⚠ WARNING

This water heater uses an external electrical source for power. It must be electrically grounded in accordance with all local codes or, in the absence of local codes, CSA C22.1 Canadian Electrical Code, in Canada, and/or the National Electrical Code, ANSI/NFPA 70, in the United States. Failure to properly ground this water heater can result in property damage, personal injury, or death.

This water heater must be connected on a separate fuse branch circuit. Check the water heater rating plate for the element wattage and voltage and make sure that the power supply wiring and the fusing or circuit breaker are the correct size for this water heater (see **Table 1**). Verify that all of the wire connections on the elements and thermostat have been installed correctly, are secure, and that none of the wires are grounded, have split, or are broken (see **WIRING DIAGRAM, Figures 11 to 24**). If any of the original wiring needs replacing, use only TEW type wire that is approved for 221°F (105°C) of the same size or greater. To hook up the water heater to the power supply, connect the power supply wiring to the power distribution block in the electrical junction box.

Table 1 — Total Full Load Current in Amperes

Total Input, kW	Voltage								
	208 Volts		240 Volts		277 Volts	480 Volts		600 Volts	
	1ph	3ph	1ph	3ph	1ph	1ph	3ph	3 ph	347V
3	14.4	—	12.5	—	10.8	6.3	—	—	—
4.5	18.3	—	18.8	—	16.3	9.4	—	—	—
5	24.0	—	20.8	—	18.0	10.4	—	—	—
6	28.8	16.7	25.0	14.4	21.7	12.5	7.2	5.8	—
9	43.3	25.0	37.5	21.7	32.5	18.8	10.8	8.7	—
10	48.0	—	41.6	—	36.0	20.8	—	—	—
12	57.7	33.3	50.0	28.9	43.5	25.0	14.4	11.5	—
13.5	64.9	37.5	56.3	32.5	48.7	28.1	16.2	13.0	—
15	72.1	41.6	62.5	36.1	54.2	31.3	18.0	14.4	—
18	86.5	50.0	75.0	43.3	65.0	37.5	21.7	17.3	—
24	115.4	66.6	100.0	57.7	86.6	50.0	28.9	23.1	—
27	129.8	74.9	112.5	65.0	97.5	56.3	32.5	26.0	—
30	144.2	83.3	125.0	72.2	108.3	62.5	36.1	28.9	—
36	173.1	99.9	150.0	86.6	130.0	75.0	43.3	34.6	—
40.5	194.7	112.4	168.8	97.4	146.2	84.4	48.7	39.0	—
45	216.3	124.9	187.5	108.3	162.5	93.8	54.1	43.3	—
54	—	—	255.0	129.9	194.9	112.5	65.0	52.0	—
63	—	—	—	—	—	—	—	60.0	—

INSTALLATION INSTRUCTIONS

Voltage

When a control transformer is installed in the electrical junction box of the water heater, make sure that the voltage on the connection of the

Transformer primary circuit is the same as the voltage on the rating plate of the water heater.

Figure 10A

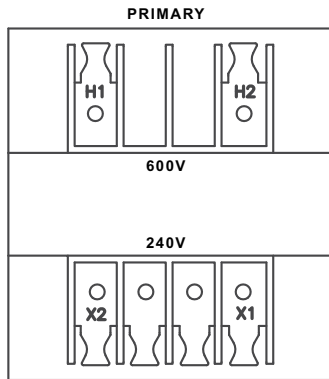

Figure 10B

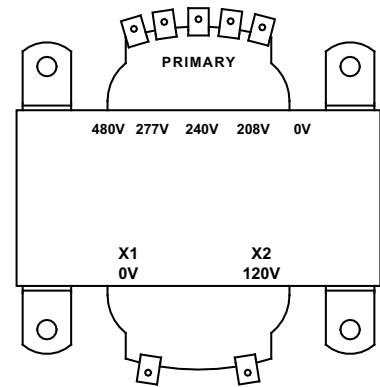
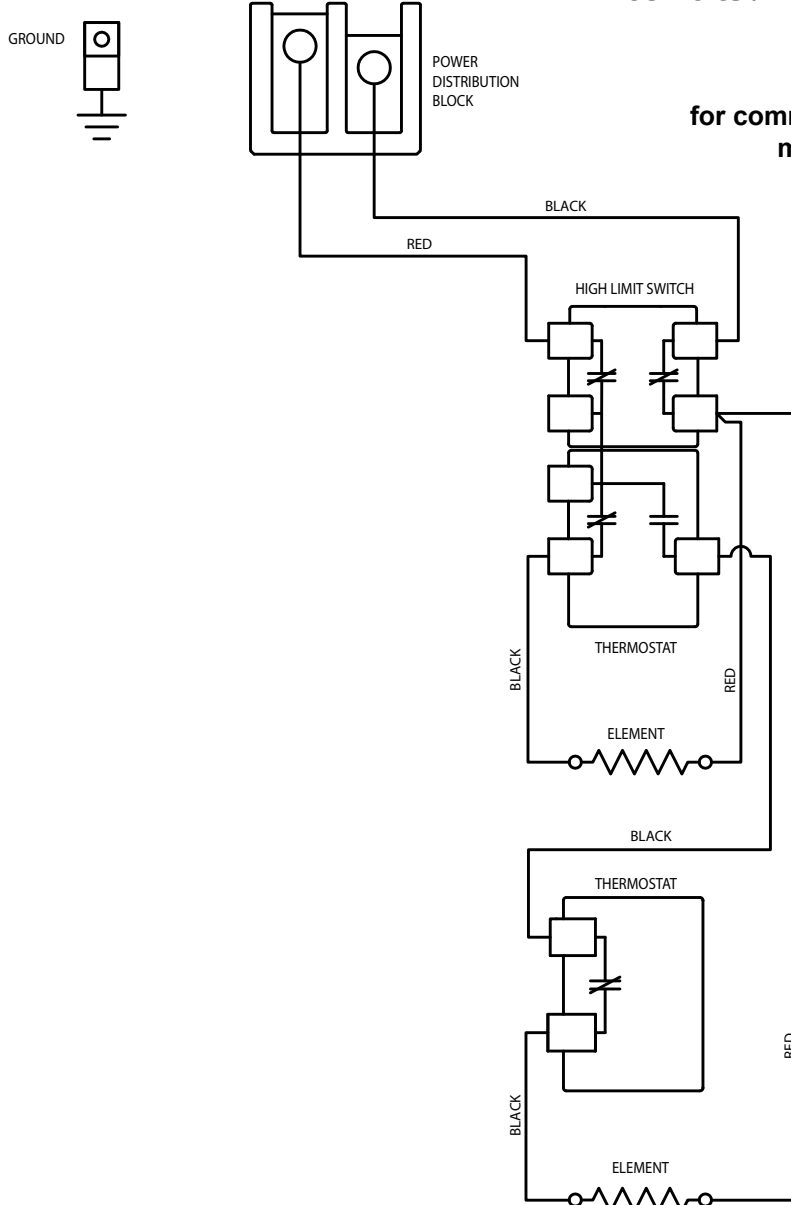

Figure 11



INSTALLATION INSTRUCTIONS

Figure 12

**208 Volts / 240 Volts / 277 Volts / 480 Volts
(single phase)**

**Wiring diagram
for commercial electric water heater
models 105, 108 & 112
with 4 elements**

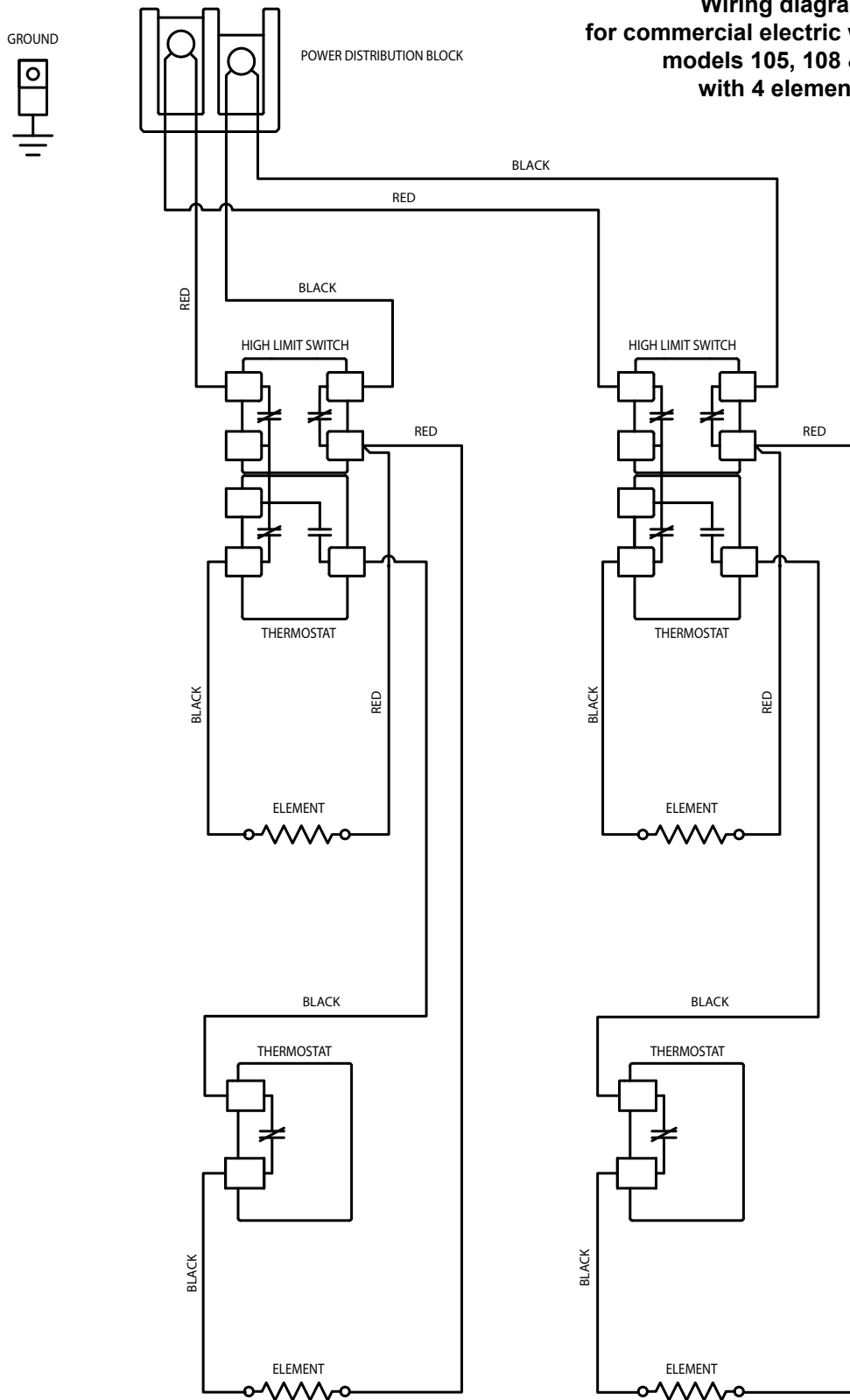

INSTALLATION INSTRUCTIONS

Figure 13

208 Volts / 240 Volts / 277 Volts / 480 Volts

Wiring diagram
for commercial electric water heater
models 105, 108
with 3 elements

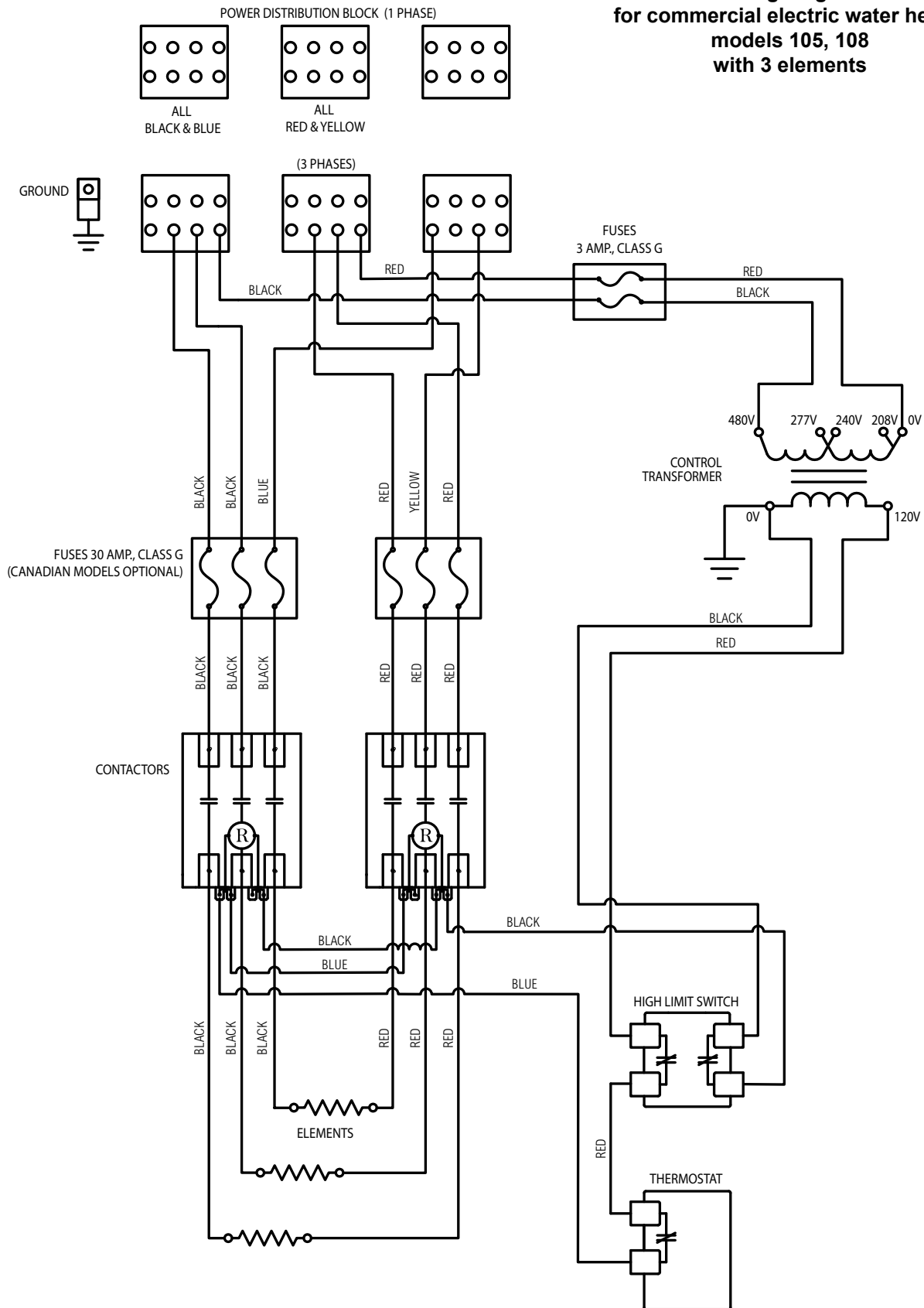

INSTALLATION INSTRUCTIONS

Figure 14

208 Volts / 240 Volts / 277 Volts / 480 Volts

Wiring diagram
for commercial electric
water heater
models 105, 108
with 6 elements

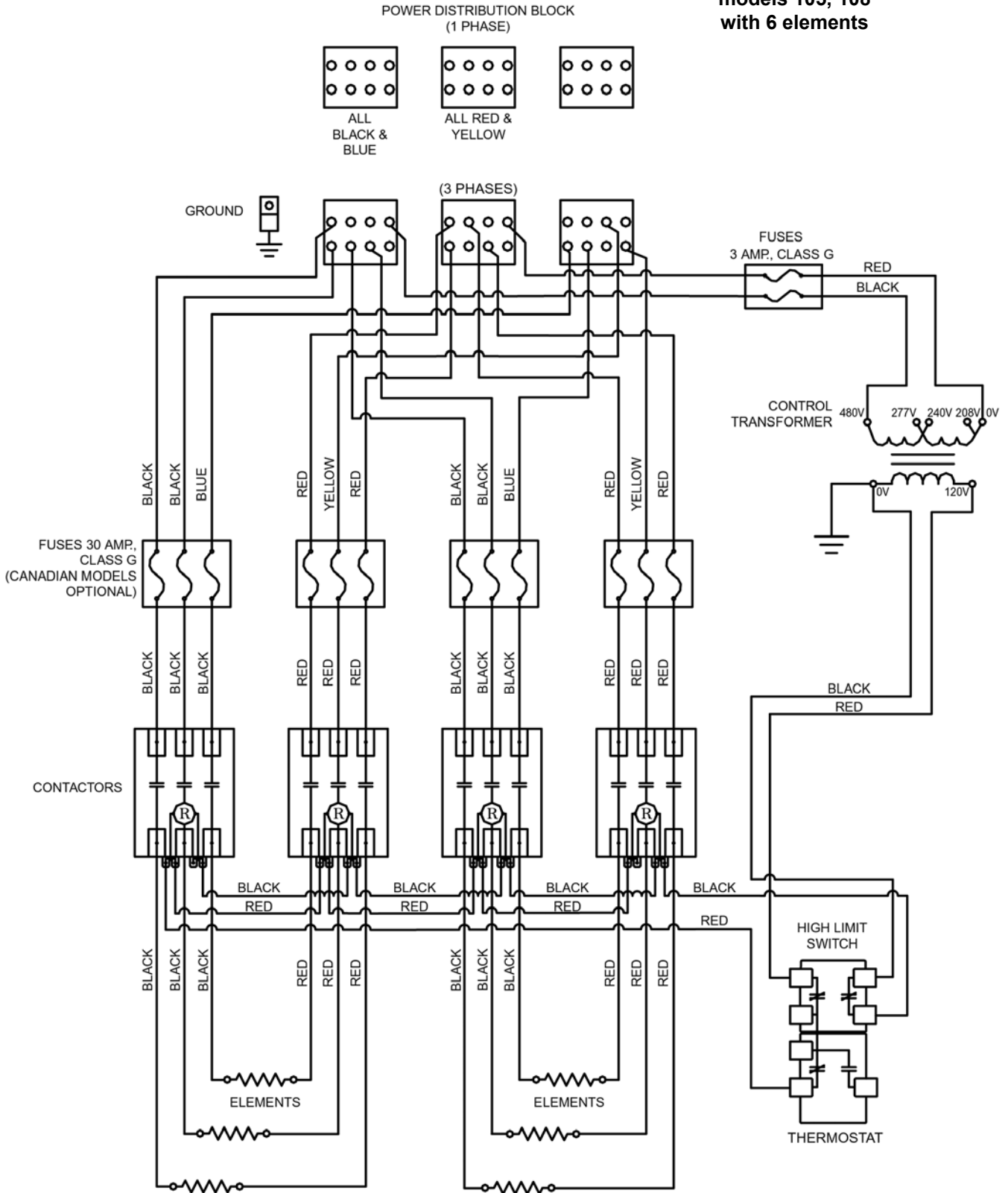

INSTALLATION INSTRUCTIONS

208 Volts / 240 Volts / 277 Volts / 480 Volts
Wiring diagram
for commercial electric water heater
models 105, 108
with 9 elements

Figure 15

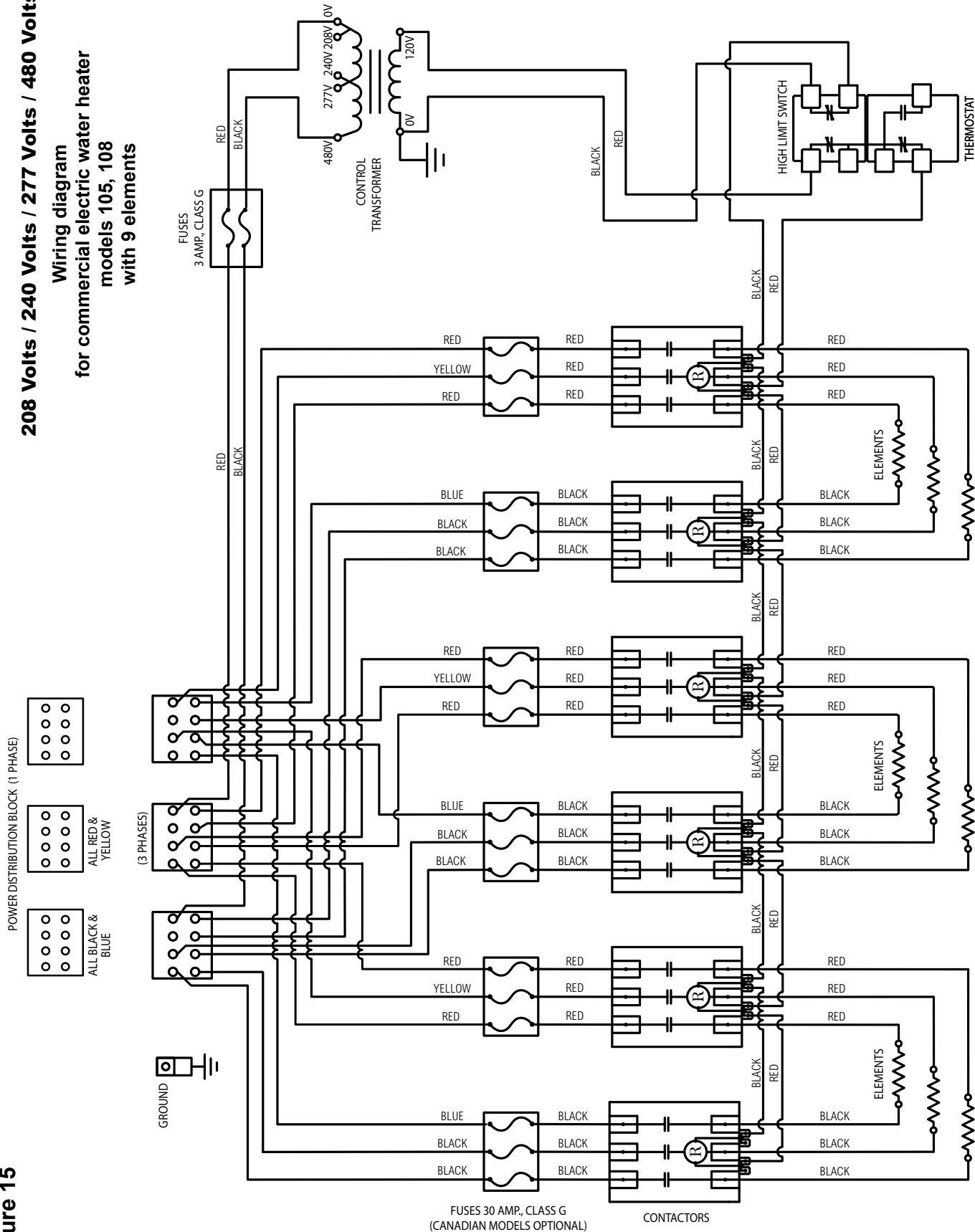

INSTALLATION INSTRUCTIONS

Figure 16

208 Volts / 240 Volts / 277 Volts / 480 Volts

Wiring diagram
for commercial electric
water heater
models 112
with 3 elements

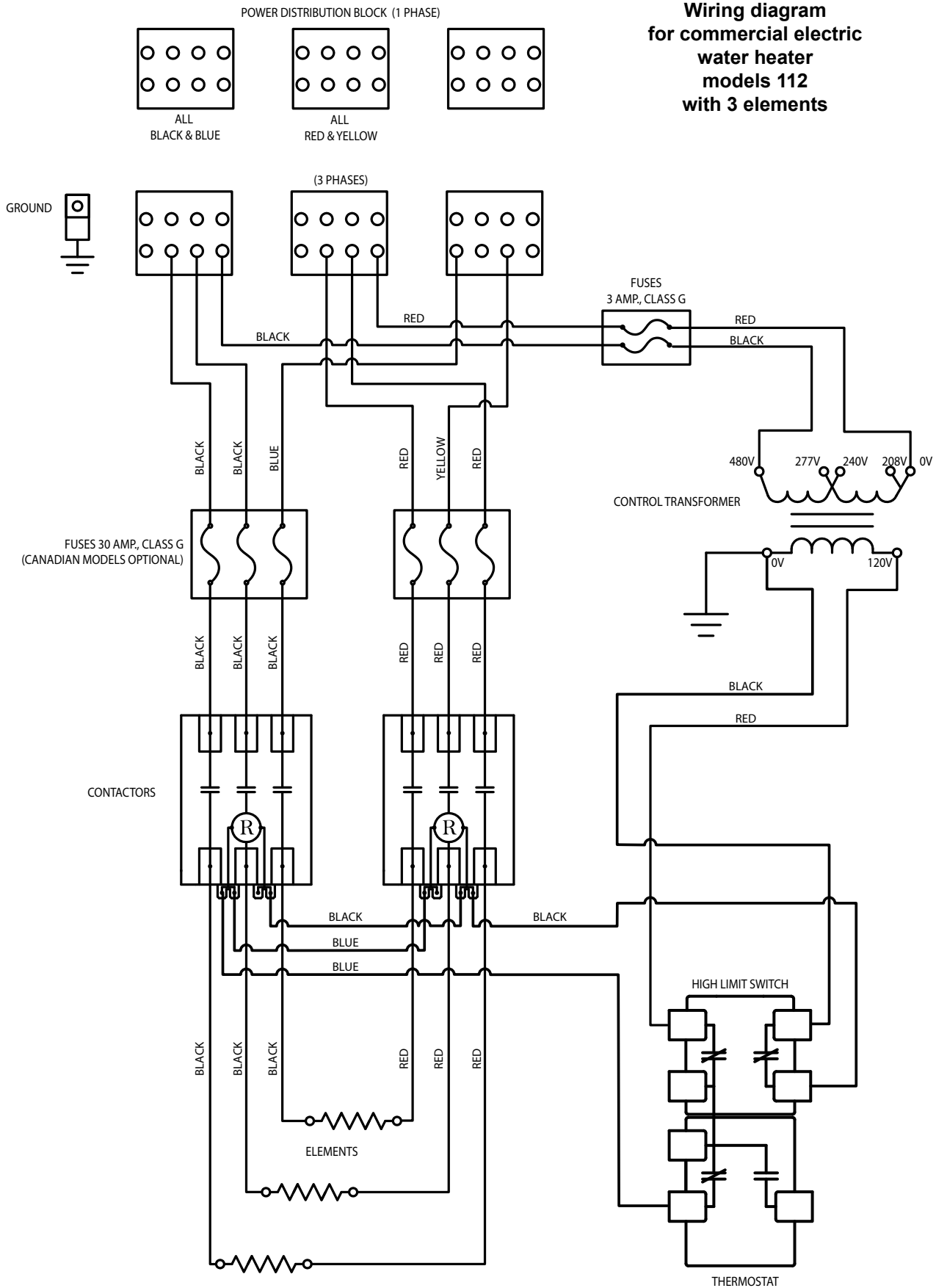

INSTALLATION INSTRUCTIONS

Figure 17

208 Volts / 240 Volts / 277 Volts / 480 Volts

Wiring diagram
for commercial electric
water heater
models 112
with 6 elements

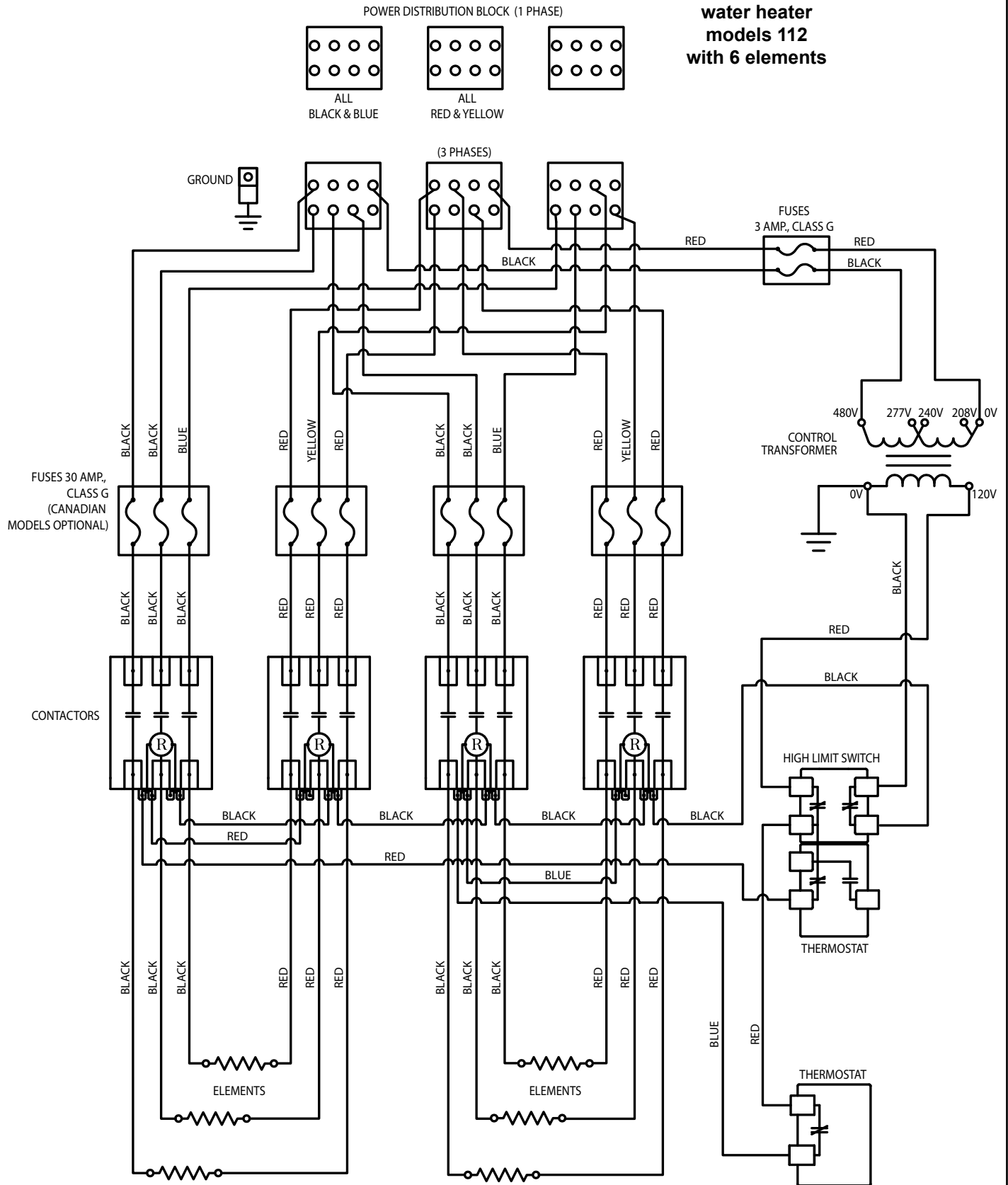

INSTALLATION INSTRUCTIONS

Figure 19

600 Volts / 3 Phases

Wiring diagram for commercial electric water heater models 105, 108 with 3 elements

(Canadian model only)

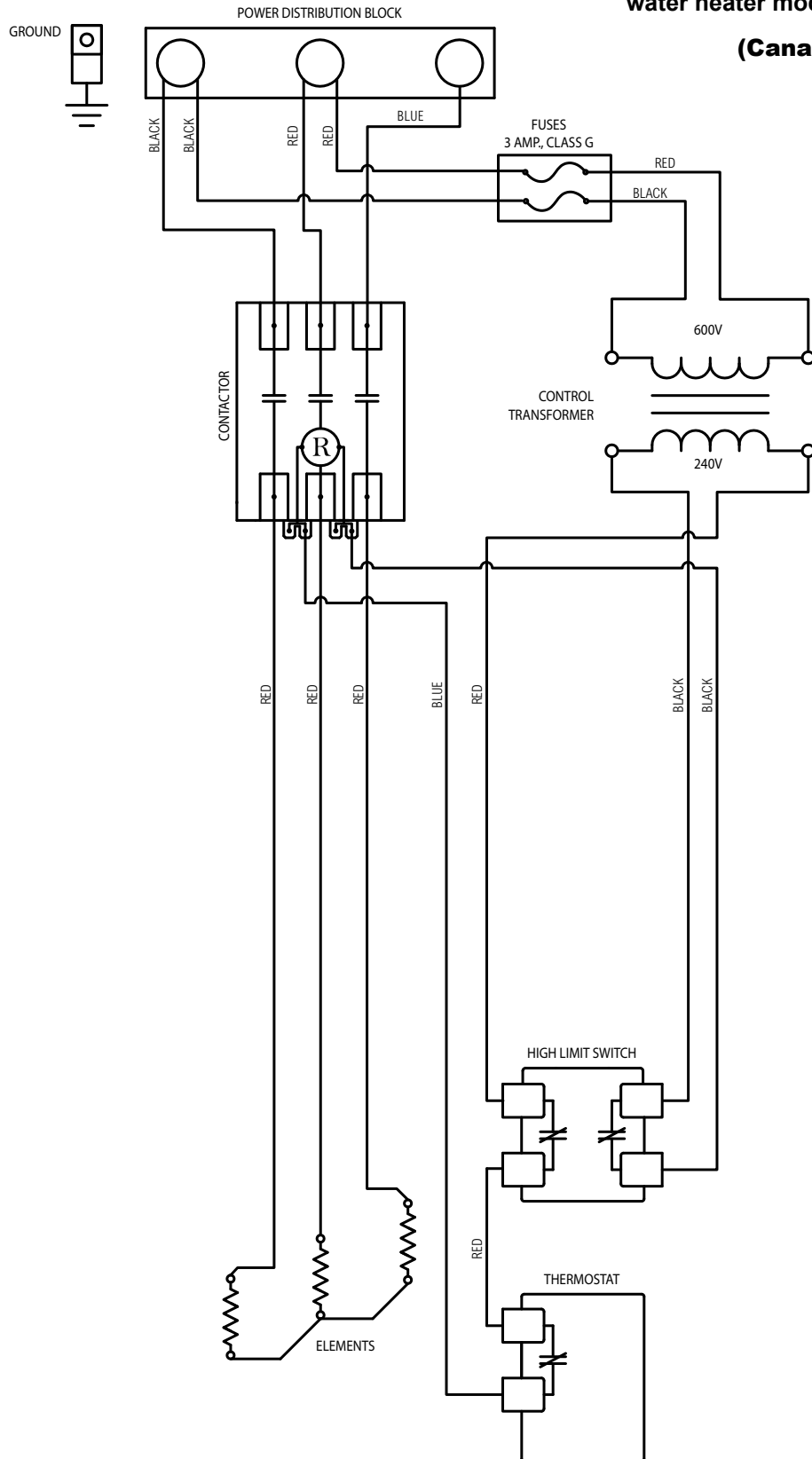

INSTALLATION INSTRUCTIONS

Figure 20

600 Volts / 3 Phases
Wiring diagram for commercial electric
water heater models 105, 108 with 6 elements
(Canadian model only)

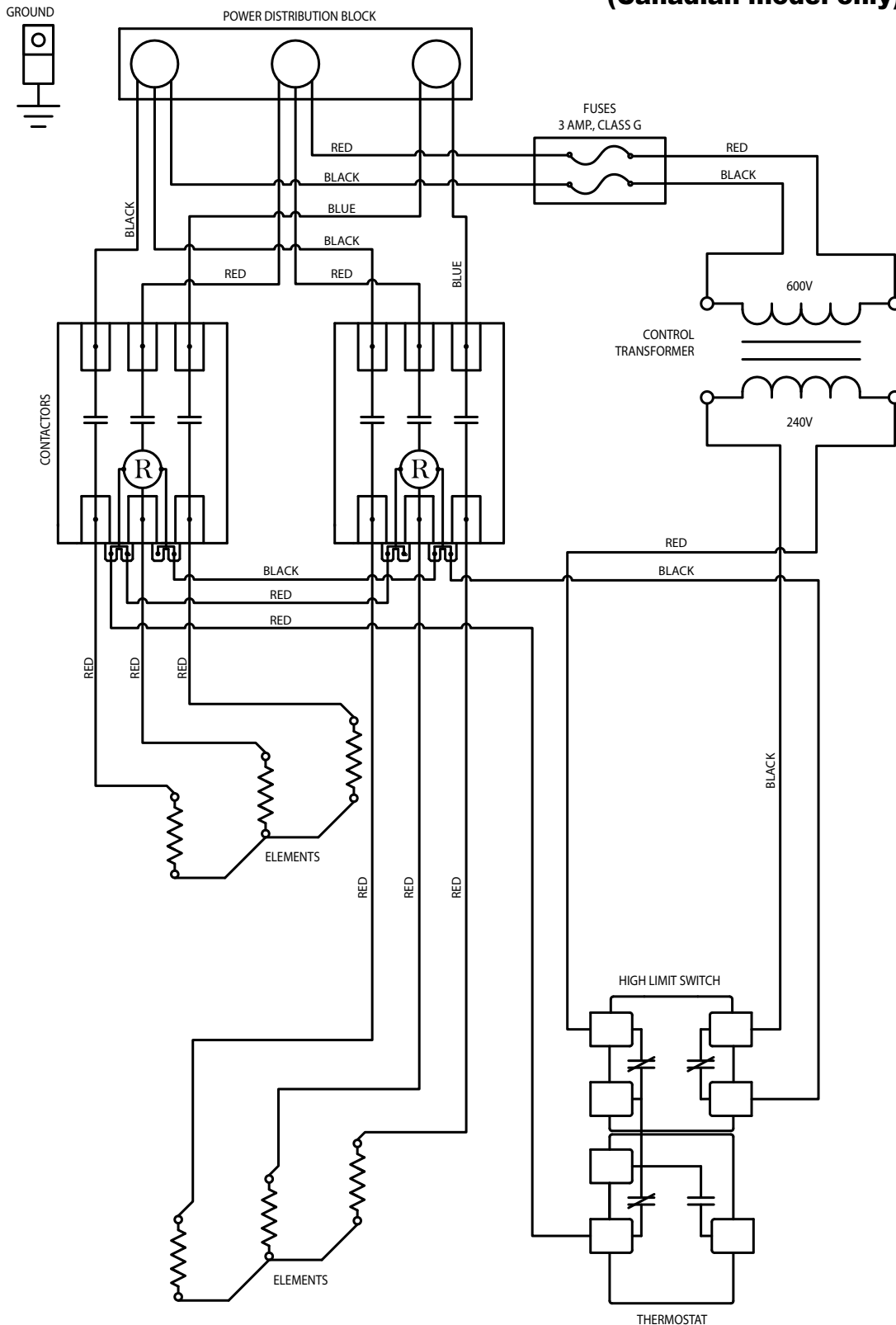

INSTALLATION INSTRUCTIONS

Figure 21

600 Volts / 3 Phases

**Wiring diagram for commercial electric water heater models 105, 108 with 9 elements
(Canadian model only)**

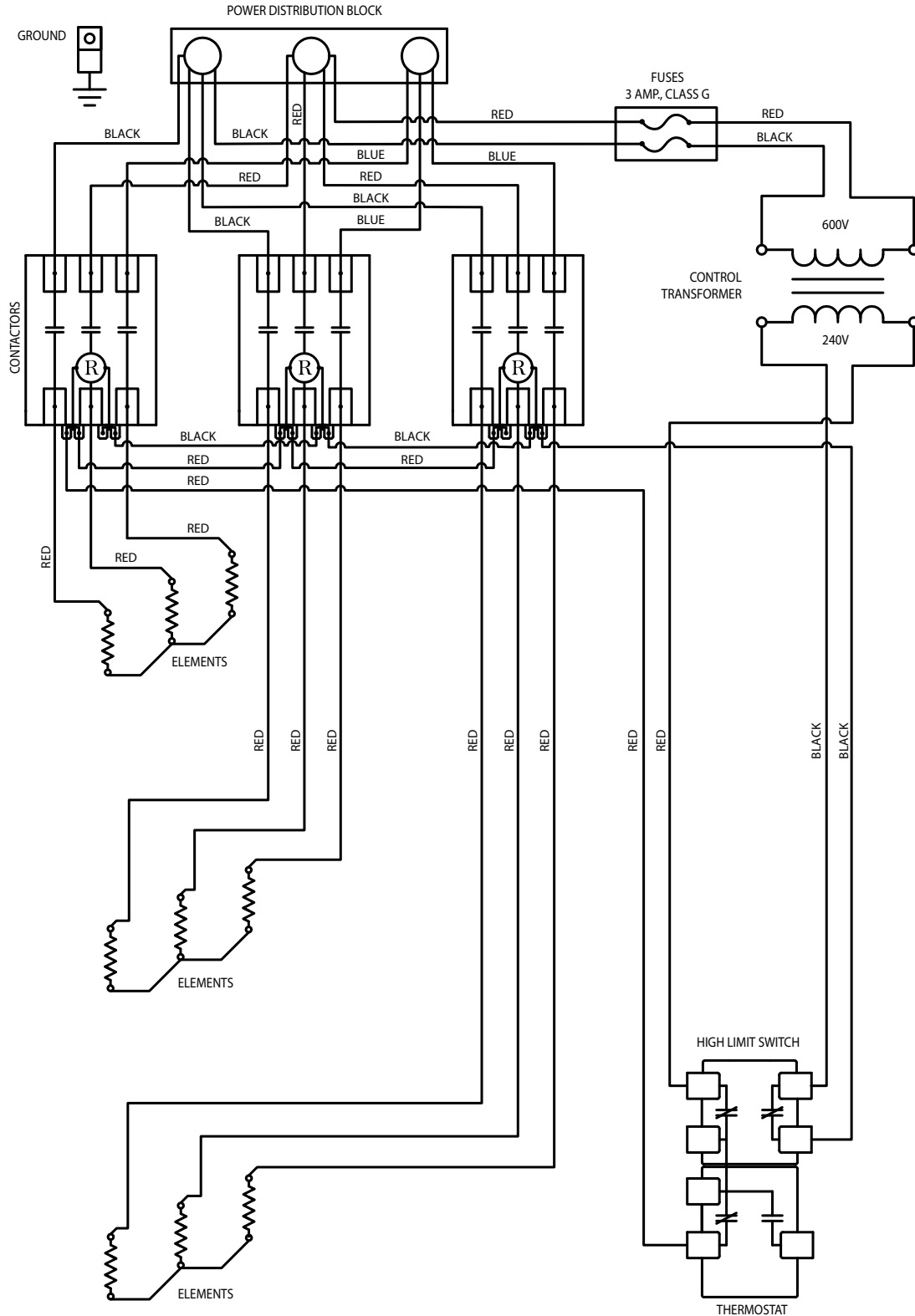

INSTALLATION INSTRUCTIONS

Figure 22

600 Volts / 3 Phases

Wiring diagram for commercial electric water heater models 112 with 3 elements

(Canadian model only)

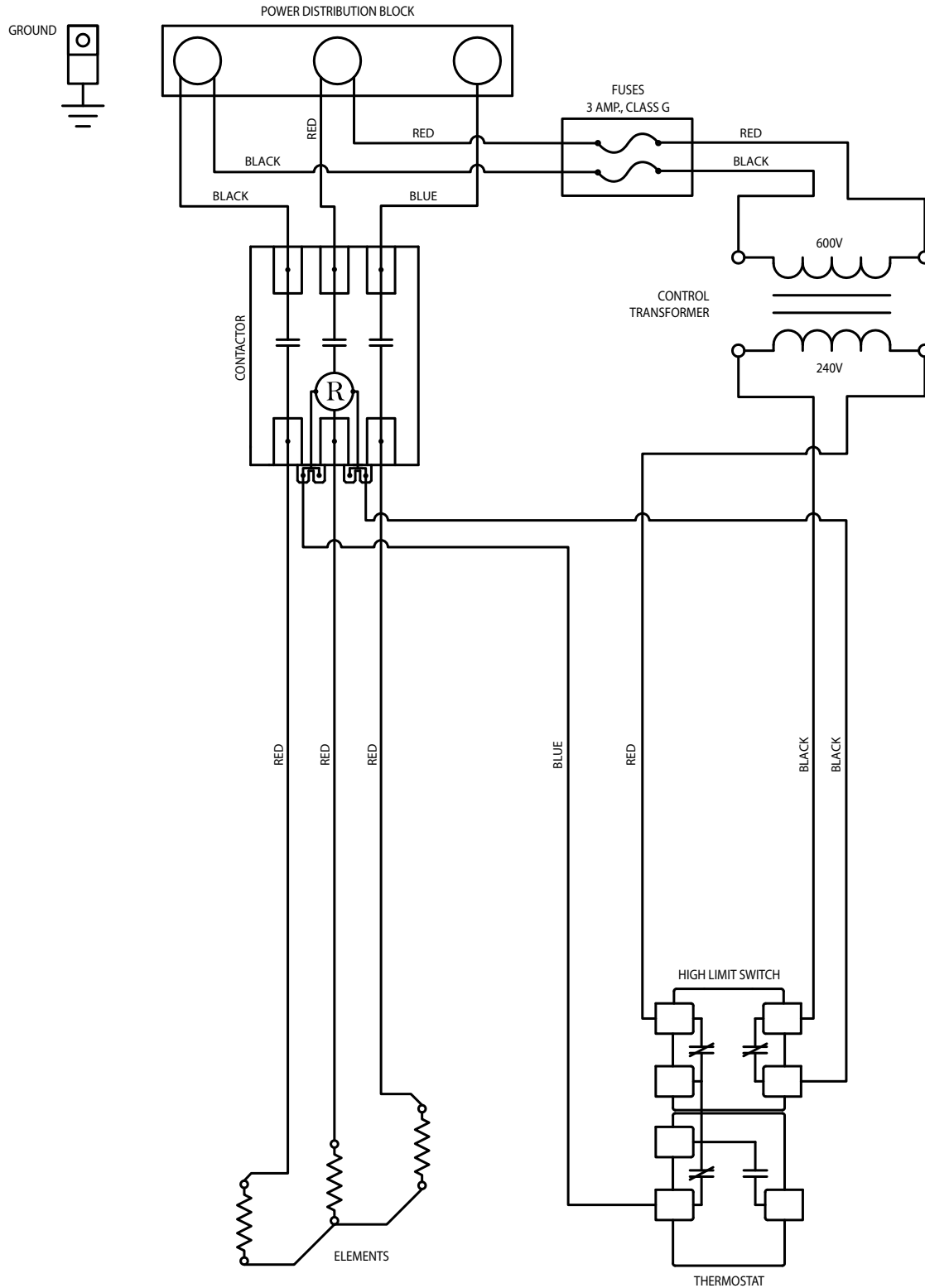

INSTALLATION INSTRUCTIONS

Figure 23

600 Volts / 3 Phases

Wiring diagram for commercial electric water heater models 112 with 6 elements

(Canadian model only)

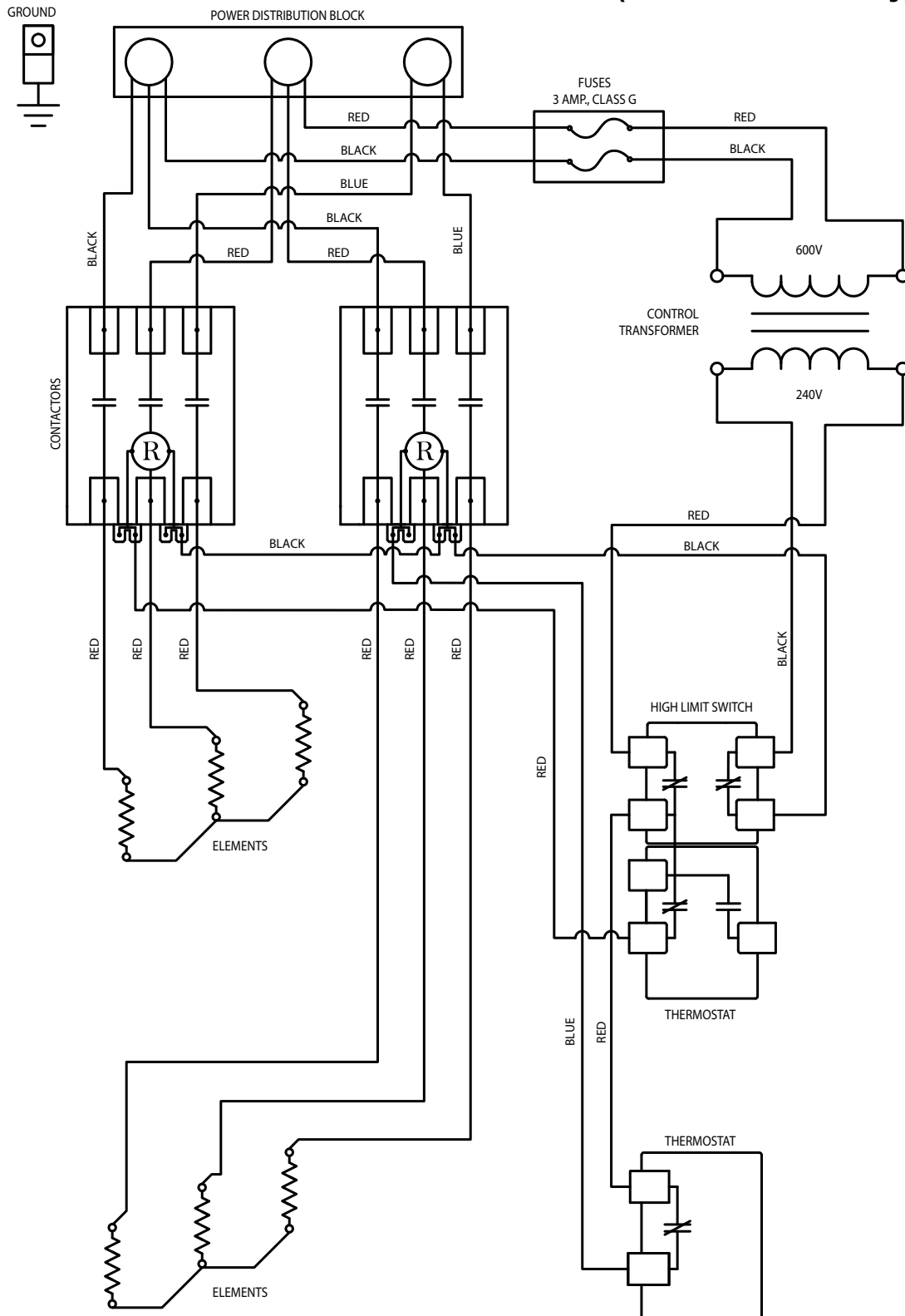

INSTALLATION INSTRUCTIONS

Figure 24

600 Volts / 3 Phases

Wiring diagram for commercial electric water heater models 112 with 9 elements

(Canadian model only)

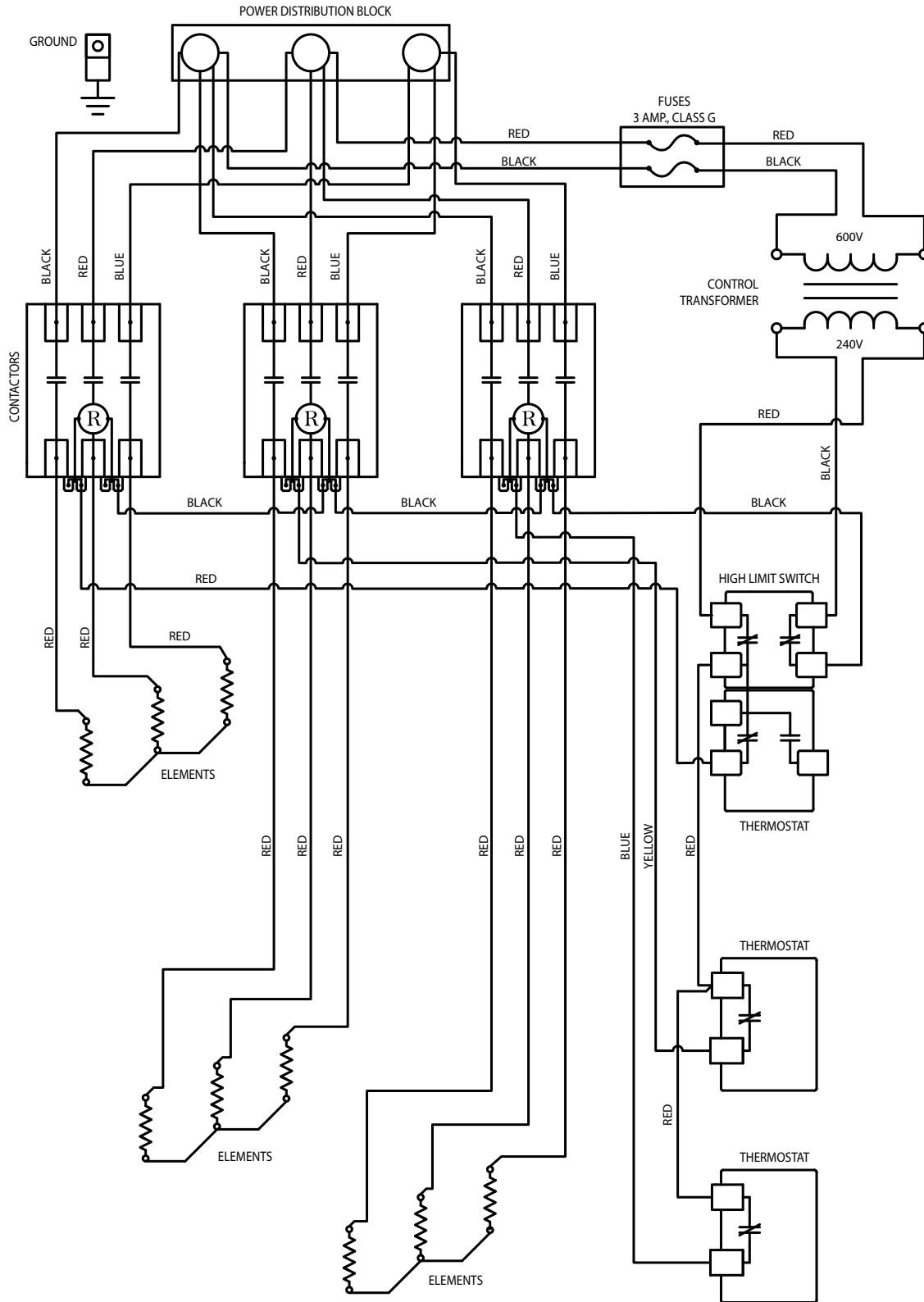

CONVERSION INSTRUCTIONS

Field Conversions

All water heaters are manufactured and shipped from the factory pre-wired for phase, voltage, and wattage conversion. **(No phase or voltage conversion on 600V Models. In addition, no other voltage can be converted to 600V).**

Phase Conversion

⚠ WARNING

600V Models cannot be converted to Single Phase.
277V Models cannot be converted to Three (3) Phases.

⚠ WARNING

Two (2) and four (4) elements water heaters are single phase and cannot be converted to three (3) phases.

⚠ WARNING

Disconnect from power supply before attempting the conversion procedure. Read all instructions before proceeding with the conversion procedure.

Surface mount thermostat

– Three (3) phases to single phase (See Figure 25)

Figure 25

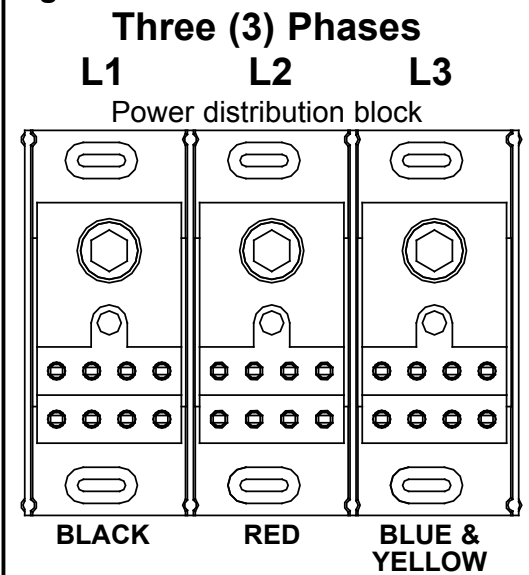

1. Disconnect all blue and yellow wires from terminal L3 on the power distribution block.
2. Reconnect all blue wires to terminal L1.
3. Reconnect all yellow wires to terminal L2.
4. Connect incoming power to terminal block L1 and L2.

Surface mount thermostat

– Single phase to three (3) phases (See Figure 26)

Figure 26

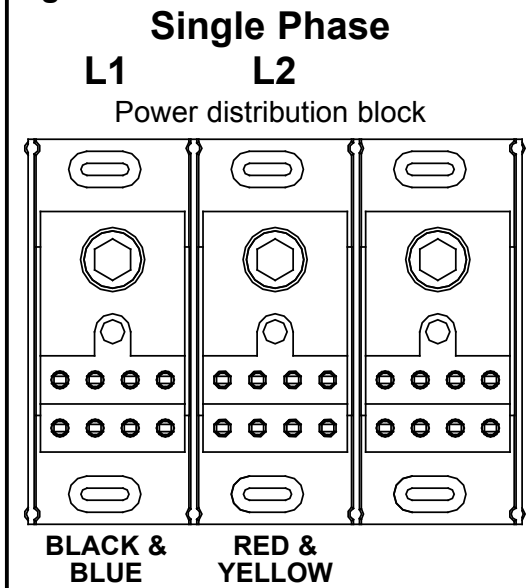

1. Disconnect all blue wires from terminal L1 on the distribution block.
2. Disconnect all yellow wires from terminal L2.
3. Reconnect all blue and yellow wires to terminal L3.
4. Connect incoming power to terminal block L1, L2, and L3

Check that all electrical connections are tightly secured and that wire routings are neat and orderly. Make sure that you have done the proper wiring as specified in these instructions and on the wiring diagram.

Note: Actual part may differ slightly from illustration depending on model.

THE STRUCTURE OF THE MODEL NUMBER

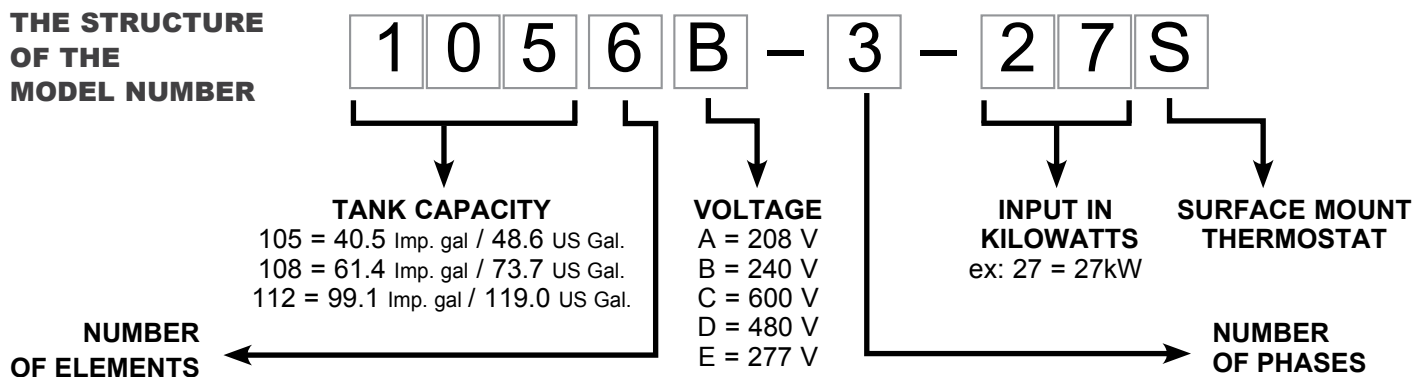

CONVERSION INSTRUCTIONS

WATTAGE AND VOLTAGE CONVERSION FOR 208V, 240V, 277V & 480V MODELS

Conversion kits are available to modify total power (kW) and/or voltage (V) of the water heater in the field. Refer to **Table 2** for the selection of the appropriate conversion kit.

1. Find the "Number of elements" in the water heater to be converted (4th digit of model number on the rating plate, **see page 23**).
2. Find the "Desired total input (kW)" in **Table 2** that matches the number of elements.

3. Then, move across the **Table 2** on the same row to the "Desired Voltage" column. The appropriate Conversion Kit part number will be the one where the "Desired total input" row intersects the "Desired Voltage" column.

Table 2

Model & Type		Number of elements	Desired Total Input, (kW)	DESIRED VOLTAGE				
				208 Volts	240 Volts	277 Volts	480 Volts	
105, 108, or 112 Models		Light Duty	2	3	06999301	06999309	06999317	06999325
			4.5	06999302	06999310	06999318	06999326	
			5	06999303	06999311	06999319	06999327	
			6	N/A	06999312	06999320	06999328	
		Medium Duty	4	6	06999305	06999313	06999321	06999329
				9	06999306	06999314	06999322	06999330
				10	06999307	06999315	06999323	06999331
				12	N/A	06999316	06999324	06999332
		Heavy Duty	3	6	06999101	06999113	06999128	06999143
				9	06999102	06999114	06999129	06999144
				12	06999103	06999115	06999130	06999145
				13.5	06999104	06999116	06999131	06999146
				15	06999105	06999117	06999132	06999147
				18	N/A	06999118	06999133	06999148
			6	18	06999106	06999119	06999134	06999149
				24	06999107	06999120	06999135	06999150
				27	06999108	06999121	06999136	06999151
				30	06999109*	06999122	06999137	06999152
				36	N/A	06999123*	06999138	06999153
				36	06999110	06999124	06999139	06999154
9	40.5	06999111	06999125	06999140	06999155			
	45	06999112	06999126	06999141	06999156			
	54	N/A	06999127	06999142	06999157			

*IMPORTANT: Any 6-element model cannot be converted to 30kW/208V - 1 phase nor 36kW/ 240V-1 phase

EXAMPLE: For a 6 element water heater to be converted to 27 kW / 480V, the appropriate Conversion Kit part number is **06999151**.

Number of elements	Desired Total Input, (kW)	Desired Voltage			
		208 Volts	240 Volts	277 Volts	480 Volts
6	18	06999106	06999119	06999134	06999149
	24	06999107	06999120	06999135	06999150
	27	06999108	06999121	06999136	06999151

Table 3

Model & Type	Number of elements	Desired Total Input, (kW)	Conversion Kit Part Numbers
105, 108, 112 600V/3 Phase Models	3	6	06999158
		9	06999159
		12	06999160
		13.5	06999161
		15	06999162
		18	06999163
	6	18	06999164
		24	06999165
		27	06999166
		30	06999167
	9	36	06999168
		36	06999169
		40.5	06999170
		45	06999171
		54	06999172

WATTAGE CONVERSION FOR 600V MODELS

Conversion kits are available to modify total power (kW) of the water heater in the field. Refer to **Table 3** for the selection of the appropriate conversion kit.

1. Find the "Number of elements" in the water heater you wish to convert.
2. Find the "Desired total input (kW)" in **Table 3** that matches your number of elements.
3. The appropriate Conversion Kit part number will be on the last column of this row.

⚠ WARNING
Voltage and phase conversion are not allowed on 600V models.

⚠ WARNING
No addition or removal of heating elements in reference to the original model is allowed in the conversion process. Failure to do so could result in electrical shock and/or property damage, personal injury, or death.

OPERATING INSTRUCTIONS

Installation Checklist

Location

- Is the water heater located close to an adequate power supply and the main use of hot water?.....
- Is the water heater protected from freezing temperatures?
- Has a drain pan been installed and piped to a free-flowing drain?.....
- Can the element and thermostat access panels be opened for inspection, adjustment, and servicing of the elements and thermostats?.....
- Is the area where the water heater is located free of flammable vapours?

Water Piping

- Has a temperature and pressure-relief valve been installed?
- Does this valve have a discharge line installed and is it piped to a free-flowing drain?.....
- Have all the plumbing connections been properly installed and are they leak free?.....
- Is the water heater completely filled with water and purged from all its air?
- Does the network have protection against thermal expansion?
- Is the piping network equipped with pre-fabricated water hammer(s) suitably selected and positioned, if required?

Wiring

- Does the power supply voltage match the voltage indicated on the water heater rating plate?
- Has the correct size of wire and fusing or circuit breaker been used to supply the water heater with power?.....
- Is the water heater electrically grounded?
- Have the electrical connections been checked, and are they secure?.....

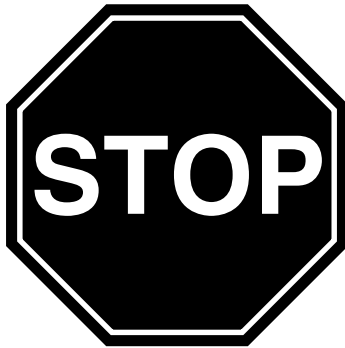

Starting the Water Heater

Before turning “ON” the power to your water heater, make sure that you have read and understood all of the instructions and warnings in this manual and on your water heater. If you have any questions about turning “ON” your water heater, immediately contact a qualified installer, service agency, or the local electric utility.

⚠ WARNING

DO NOT turn “ON” the power to this water heater if:

- It is not completely filled with water and purged from all its air.
- The power supply voltage does not match the voltage listed on the rating plate.
- Gasoline or other flammable vapours and liquids have been stored in the vicinity of the water heater.

Failure to follow these instructions can result in property damage, personal injury, or death.

⚠ WARNING

If the information in these instructions is not followed exactly, a fire or explosion may result causing property damage, personal injury, or death.

- **DO NOT** open the electrical junction box or the element access panel before the power to the water heater is turned “OFF”.
- **DO NOT ATTEMPT** to repair or replace any of the electrical components installed on the water heater before the power to the water heater is turned “OFF”.
- **DO NOT USE** the water heater on a voltage other than that specified on the water heater rating plate.
- **DO NOT CONNECT** the power supply wiring to anywhere other than the power distribution block in electrical junction box of the water heater.
- **DO NOT TURN ON** the power to the water heater unless it is completely filled with water and purged from all its air.
- **DO NOT DRAIN** the water heater unless the power to the water heater has been turned “OFF”.
- **DO NOT STORE** or use gasoline or other flammable vapours and liquids in the vicinity of this or any other appliance.

WHAT TO DO IF YOU SMELL SMOKE

- Immediately turn “OFF” the power to the water heater.
- If after turning “OFF” the power the smoke continues, call your local fire department.
- When the smoke has stopped, call a qualified service technician to identify and repair the problem.

OPERATING INSTRUCTIONS

Start-up Procedure

- 1) Turn «ON» the circuit breaker at the main service panel.
- 2) Make sure the fuse box or power switch (if one exists) next to the water heater is pushed to «ON».
- 3) If you smell smoke, refer to **What to do if you smell smoke**.
- 4) Hot water should be available at the faucet within thirty (30) to sixty (60) minutes.
- 5) If after one (1) hour you do not have any hot water, check that the fuse or circuit breaker is in working condition.
- 6) If at this time you still do not have any hot water, call a qualified service technician.

Note: If after one (1) hour you receive only a small amount of hot water, check that the plumbing connections are not reversed.

Safety Controls

This water heater is equipped with a combination thermostat and high limit switch that is located above the upper heating element. If for any reason the temperature of the water becomes excessively high, the high limit switch will open the circuit to the heating elements. Once the control opens, it must be reset manually (**See Figure 27**).

To reset the high limit switch:

- 1) Turn «OFF» the power to the water heater.
- 2) Open the elements and thermostat(s) access panel and remove the insulation.
- 3) Press the red reset button on the high limit switch.
- 4) Replace the insulation and close the element access panel before turning «ON» the power to the water heater.

Water Temperature Regulation

The higher the setting, the greater the risk of scalding. Hot water can cause third degree burns in less than one (1) second at 160°F (71°C), in five (5) seconds at 140°F (60°C), and in thirty (30) seconds at 130°F (54°C). In households where there are children, physically challenged individuals, or seniors, mixing valves for point of use are necessary as means of reducing the scalding potential of hot water. The thermostat is factory set at 140°F (60°C) on all models.

To adjust the temperature on the thermostat:

- 1) Turn «OFF» the power to the water heater.
- 2) Open the elements and thermostat(s) access panel and remove the insulation. (**DO NOT** remove the thermostat protective cover if so equipped).
- 3) Using a small flat-head screwdriver, turn the thermostat dial to the desired temperature setting (**see Table 4**).
- 4) Replace the insulation and close the elements and thermostat(s) access panel before turning «ON» the power to the water heater.

Table 4

TEMPERATURE EQUIVALENCE	
HOT	120°F / 48.9°C
A	130°F / 54.4°C
B	140°F / 60.0°C
C	150°F / 65.5°C
VERY HOT	160°F / 71.1°C

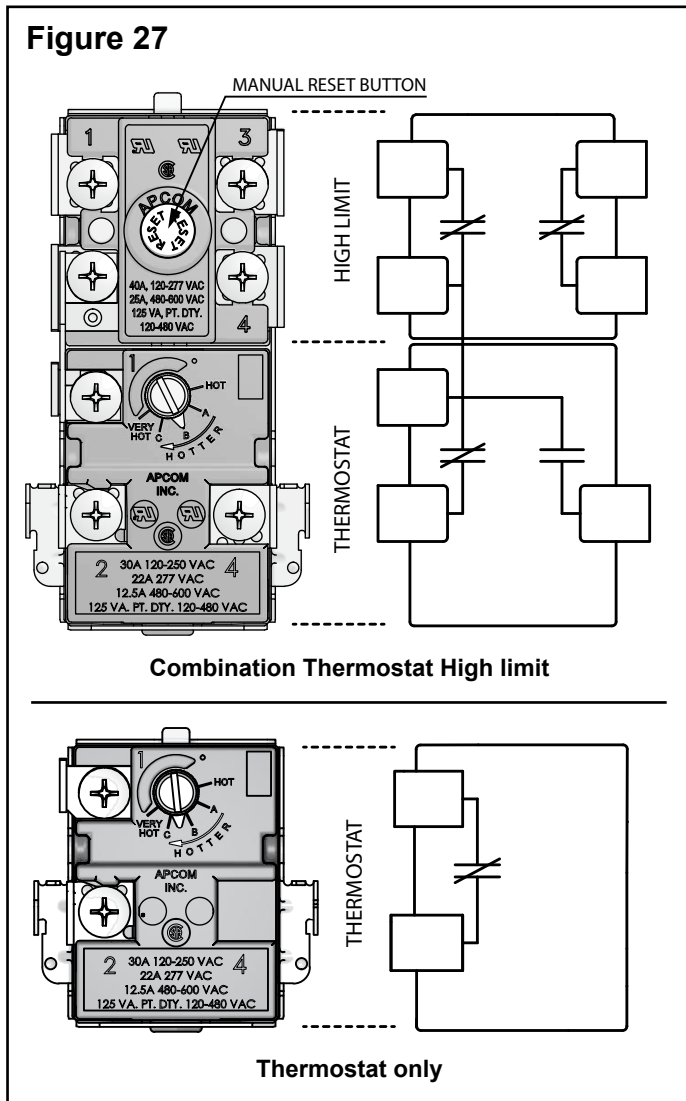

GENERAL MAINTENANCE

Clean Out Access

The water heater is supplied with a clean-out access door to enable removal of sediment inside the tank during the maintenance. Remove access door covering the clean-out door. **You must always turn off the power and drain the tank completely before removing the clean-out door by removing all six (6) screws.** When maintenance is complete install clean-out door with a new gasket making sure the surface is clean on the flange of the tank.

Element and Thermostat Replacement

⚠ WARNING

Before attempting to repair or replace any of the electrical components on this water heater, turn "OFF" the power to the water heater. Failure to do so could result in electrical shock and/or property damage, personal injury, or death.

Replacing an Element

- 1) Turn "OFF" the power to the water heater and drain all of the water from the water heater (see *Draining the Water Heater*, page 28).
- 2) Open the elements and thermostat(s) access cover and remove the insulation.
- 3) Disconnect the wires from the element terminals.
- 4) Unscrew the four (4) bolts securing the element to the water heater and pull element out of the tank. Make sure the TWIST-LOCK flange is in the right position (See Figure 28).

Figure 28 TWIST-LOCK

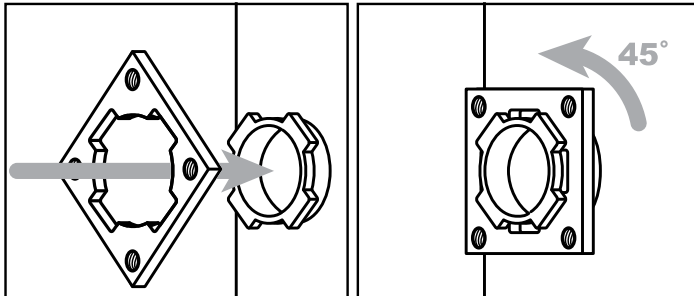

- 5) Replace the element with a new element of the same wattage and voltage. Make sure that the gasket surface is clean and that the element has been re-installed water-tight with a new gasket.

⚠ IMPORTANT

Make sure that the elements are properly oriented as illustrated on the following figures. (Orientation of the text on the element flange is important). (See Figures 29 and 30)

Figure 29

105 et 108 models

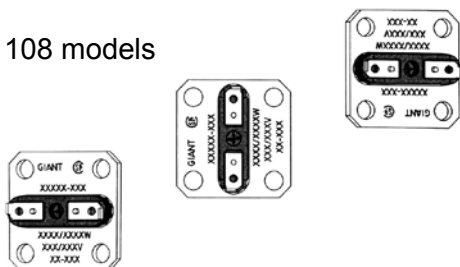
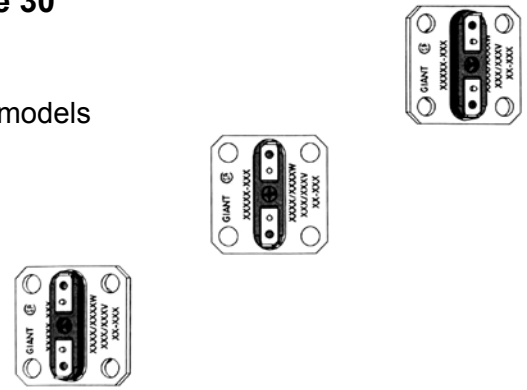

Figure 30

112 models



- 6) Re-connect the wires to the element and tighten securely.
- 7) Re-fill the water heater (see *Filing the Water Heater*, page 5). **DO NOT TURN THE POWER ON TO THE WATER HEATER UNLESS YOU ARE SURE IT IS COMPLETELY FILLED WITH WATER.**
- 8) Replace the insulation and close the elements and thermostat(s) access panel before turning "ON" the power to the water heater.

Replacing a Thermostat

(See *Replacement Parts*, page 29 to 33)

- 1) Turn "OFF" the power to the water heater.
- 2) Open the elements and thermostat(s) access panel and remove the insulation.
- 3) Disconnect the wires from the thermostat terminals.
- 4) Lift the thermostat bracket arms and slide the thermostat up to remove it.
- 5) Replace the thermostat with a new thermostat of the same manufacturer and type.
- 6) Reconnect the wires on the thermostat terminals referring to the corresponding wiring diagram in **Figures 11 to 24**.
- 7) Set the thermostat to the desired temperature (see *Water Temperature Regulation*, page 26).
- 8) Replace the insulation and close the elements and thermostat(s) access panel before turning "ON" the power to the water heater.

Temperature and Pressure-Relief Valve

Manually operate the temperature and pressure-relief valve at least once a year, standing clear of the outlet to avoid being burned. Lift and release the operating lever on the valve to make it operate freely. If, after manually operating the valve, it fails to completely reset itself and continues to discharge water, replace it with a new one.

Anodes

This water heater is equipped with two (2) magnesium anodes that are designed to prolong the life of the glass-lined inner tank. The anodes are slowly consumed, protecting the glass-lined tank from corrosion. They should be checked every two (2) years. If more than half of any anode has been consumed, it should be replaced. Instructions on how to change an anode can be obtained from the manufacturer.

GENERAL MAINTENANCE

The life expectancy of the water heater is reduced where a water softener is introduced to fight hard water, because the sodium salts added by a softener make this water extremely conductive. In these conditions, the magnesium anodes are consumed more rapidly and should be verified every year.

In certain water conditions, the magnesium anodes will react with the water, producing discoloured or smelly water. The most common complaint is hot water that smells like rotten eggs. This phenomenon is the result of the reaction between the magnesium anodes and hydrogen sulfide gas dissolved in the water, which occurs frequently in well systems. This problem can usually be eliminated or reduced by changing the anodes to a type more suitable for these conditions (aluminum anodes) and by chlorinating the water heater and the plumbing system. If the problem persists, special filtration equipment may be required. Under no circumstances are the anodes to be removed from the water heater on a permanent basis. **Removal of the anodes will lead to premature failure of the water heater and void the warranty.**

⚠ WARNING

Hydrogen gas can be produced in a hot water system that has not been used for a long period of time (generally two [2] weeks or more). **HYDROGEN GAS IS EXTREMELY FLAMMABLE.** It is highly recommended to open a hot water faucet for several minutes before you use any electrical appliances connected to the hot water system, such as a dishwasher or washing machine. If hydrogen gas is present, there will be an unusual sound, such as air escaping through the pipe, as the hot water faucet is opened. **DO NOT** smoke or introduce an open flame near the faucet when it is opened.

Draining the Water Heater

Drain a pail of water through the drain valve at least once a year. This will remove excess sediment from the bottom of the tank. This sediment, if allowed to accumulate, will reduce the efficiency and the life of the tank.

To completely drain the water heater:

- 1) Turn “**OFF**” the power to the water heater.
- 2) Close the cold water supply manual shut-off valve.
- 3) Connect one end of a garden hose to the water heater drain valve and put the other end next to a free-flowing drain.
- 4) Open the drain valve by inserting a flat-head screwdriver into the slot on the head of the drain valve and turning the knob counterclockwise .
- 5) Open a hot water faucet to allow air into the system.

Vacation

If you are planning a vacation or other prolonged absence, it is essential to turn “**OFF**” the power to the water heater and the cold water supply to the water heater. This preventive action will save energy, protect against property damage in the event the water heater leaks, and prevent the build-up of hydrogen gas. If the water heater and piping are exposed to freezing temperatures, they should both be drained. Remember to check the water heater thoroughly after it has been shut off for an extended period of time before putting it back in operation. Make sure that the water heater is completely full of water, and that the cold water supply manual shut-off valve is open, before turning “**ON**” the power to the water heater.

Getting Service for your Water Heater

If you are having problems with your water heater, follow these three easy steps:

- 1) Read the **Troubleshooting Guide** contained in this manual (see **Page 34**). It lists the most common problems experienced with your electric water heater. The solutions you find listed may provide a quick and simple solution to your problem and save you time and money.
- 2) If the solution listed in the **Troubleshooting Guide** does not solve the problem or if your particular problem is not listed in the guide, contact the installer of the water heater, or the local electric utility.
- 3) If you still cannot solve the problem, contact the manufacturer's Customer Service Department by e-mail at service@giantinc.com or by telephone at **1-800-363-9354** (option 1). To help serve you in a quick and efficient manner, **always have the following information ready:**
 - a) Model number.
 - b) Serial number.
 - c) Date of installation.
 - d) Where the water heater was purchased.
 - e) Complete address where the water heater is installed.
 - f) A description of the problem.

REPLACEMENT PARTS

Item	Part number	Description	Models
1	87000014-A	Snap-in plug	All
2	MS155410	Magnesium anodes	105
	MS155520		108
	MS166530		112
3	16000008-A	Outlet nipple 1½" X 3"	All
4	TB587001	Terminal block end	Single phase
5	99001204-A	Twist-lock flange with screws	All
6	18G0002	Square flange element gasket	All
7	SEE ELEMENT TABLE BELOW		
8	56000016-A	Combination thermostat / high limit	All
9	18G0001	Thermostat bracket	All
10	99000061-A	Jacket door	All
11	25004111-A	Clean-out cover	All
12	GA1N1110	Clean-out gasket	All
13	DV3Z0070	Brass drain valve	All
14	16001402-A	Inlet nipple 1½" X 4"	All
15	56000018-A	Lower thermostat	All
16	SV0N3020	T&P relief valve	All
17	16000015-A	Relief nipple ¾" X 3½"	All

**208 Volts, 240 Volts,
277 Volts, 480 Volts**

**105, 108 & 112 models
with 2 or 4 elements**

ELEMENT TABLE

Part #	Watts	Volts
9AG30/80	3,000W	208V
9AG45/80	4,500W	
9AG50/90	5,000W	
10G30/80	3,000W	240V
10G45/80	4,500W	
10G50/90	5,000W	
10G60/100	6,000W	
11G30/80	3,000W	277V
11G45/80	4,500W	
11G50/90	5,000W	
11G60/100	6,000W	
13G30/80	3,000W	480V
13G45/80	4,500W	
13G50/90	5,000W	
13G60/100	6,000W	

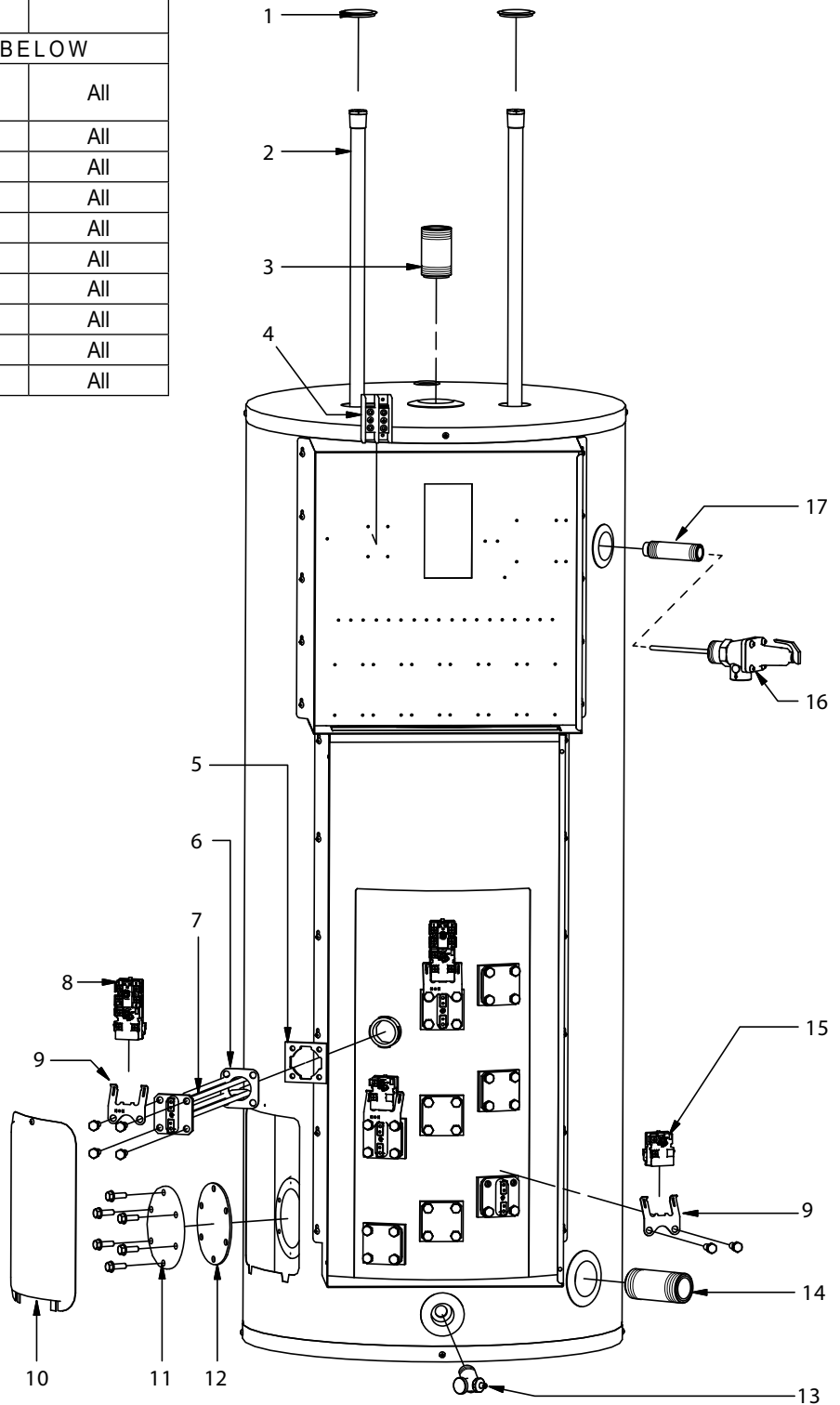

Illustration shows Model 108 with 4 elements

REPLACEMENT PARTS

Item	Part number	Description	Models
1	87000014-A	Snap-in plug	All
2	MS155410	Magnesium anodes	105
	MS155520		108
3	16000008-A	Outlet nipple 1½" X 3"	All
4	32000008-A	Terminal block three phases	3 elements
	32000007-A		6 elements
	32000009-A		9 elements
5	34001005-A	Fuse Holder (2P)	All
6	34000003-A	Fuses (3 amps Class G)	All
7	34001004-A	Fuse Holders (3P)	*US models (-US)
8	34000004-A	Fuses (30 amps Class G)	*US models
9	43000008-A	Contactors HCC-3XT02CY	All
10	99001204-A	Twist-lock flange with screws	All
11	18G0002	Square flange element gasket	All
12	SEE ELEMENT TABLE BELOW		
13	56000016-A	Combination thermostat / high limit	All except 1053 & 1083
	56000022-A	High limit	1053 & 1083
14	GA1N1110	Clean-out gasket	All
15	25004111-A	Clean-out cover	All
16	99000061-A	Jacket door	All
17	18G0001	Thermostat bracket	All
18	DV3Z0070	Brass drain valve	All
19	56000018-A	Lower thermostat	1053 & 1083
20	16001402-A	Inlet nipple 1½" X 4"	All
21	SV0N3020	T&P relief valve	All
22	16000015-A	Relief nipple ¾" X 3½"	All
23	44000004-A	Transformer Multi-tap /120V	All

* Optional for Canadian Models

ELEMENT TABLE

Part #	Watts	Volts
9AG20/80	2,000W	208V
9AG30/80	3,000W	
9AG40/80	4,000W	
9AG45/80	4,500W	
9AG50/90	5,000W	
10G20/80	2,000W	240V
10G30/80	3,000W	
10G40/80	4,000W	
10G45/80	4,500W	
10G50/90	5,000W	
10G60/100	6,000W	
11G20/80	2,000W	277V
11G30/80	3,000W	
11G40/80	4,000W	
11G45/80	4,500W	
11G50/90	5,000W	
11G60/100	6,000W	
13G20/80	2,000W	480V
13G30/80	3,000W	
13G40/80	4,000W	
13G45/80	4,500W	
13G50/90	5,000W	
13G60/100	6,000W	

**208 Volts, 240 Volts,
277 Volts, 480 Volts**

105, 108 models
with 3, 6, or 9 elements

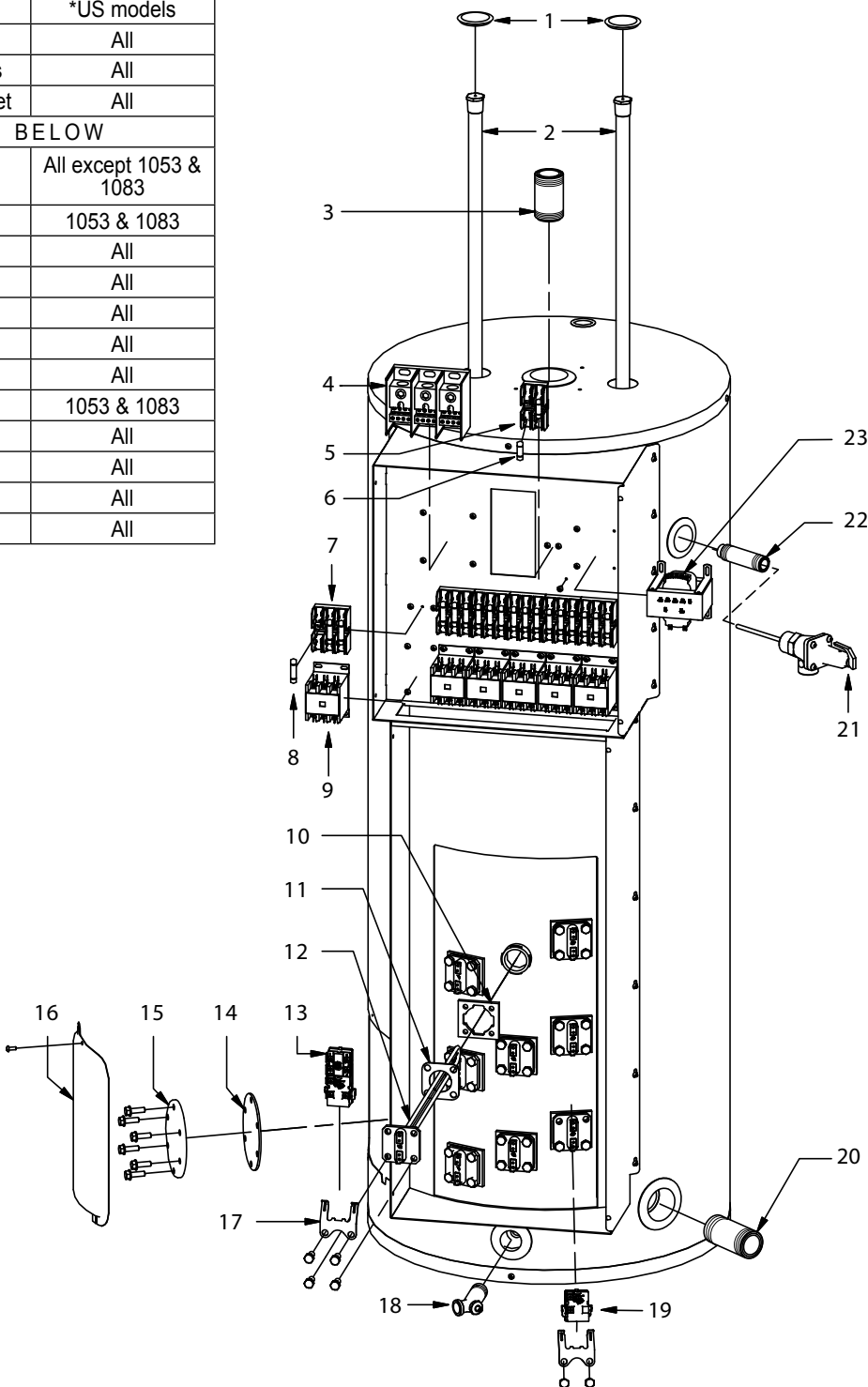

Illustration shows Model 108 with 9 elements

REPLACEMENT PARTS

Item	Part number	Description	Models
1	87000014-A	Snap-in plug	All
2	MS166530	Magnesium anodes	112
3	16000008-A	Outlet nipple 1½" X 3"	All
4	32000008-A	Terminal block three phases	All 3 elements
	32000007-A		All 6 elements
	32000009-A		All 9 elements
5	34001005-A	Fuse Holder (2P)	All
6	34000003-A	Fuses (3 amps Class G)	All
7	34001004-A	Fuse Holders (3P)	*US models (-US)
8	34000004-A	Fuses (30 amps Class G)	*US models
9	43000008-A	Contactors HCC-3XT02CY	All
10	25004111-A	Clean-out cover	All
11	GA1N1110	Clean-out gasket	All
12	99000061-A	Jacket door	All
13	DV3Z0070	Brass drain valve	All
14	16001402-A	Inlet nipple 1½" X 4"	All
15	56000018-A	Lower thermostat	All except 1123
16	56000018-A	Middle thermostat	1129 only
17	18G0001	Thermostat bracket	All
18	56000016-A	Combination thermostat / high limit	1126, 1129 top, 1123 bottom
19	SEE ELEMENT TABLE BELOW		
20	18G0002	Square flange element gasket	All
21	99001204-A	Twist-lock flange with screws	All
22	SV0N3020	T&P relief valve	All
23	16000015-A	Relief nipple ¾" X 3½"	All
24	44000004-A	Transformer Multi-tap /120V	All

* Optional for Canadian Models

ELEMENT TABLE

Part #	Watts	Volts
9AG20/80	2,000W	208V
9AG30/80	3,000W	
9AG40/80	4,000W	
9AG45/80	4,500W	
9AG50/90	5,000W	
10G20/80	2,000W	240V
10G30/80	3,000W	
10G40/80	4,000W	
10G45/80	4,500W	
10G50/90	5,000W	
10G60/100	6,000W	
11G20/80	2,000W	277V
11G30/80	3,000W	
11G40/80	4,000W	
11G45/80	4,500W	
11G50/90	5,000W	
11G60/100	6,000W	
13G20/80	2,000W	480V
13G30/80	3,000W	
13G40/80	4,000W	
13G45/80	4,500W	
13G50/90	5,000W	
13G60/100	6,000W	

**208 Volts, 240 Volts,
277 Volts, 480 Volts**

**112 model
with 3, 6, or 9 elements**

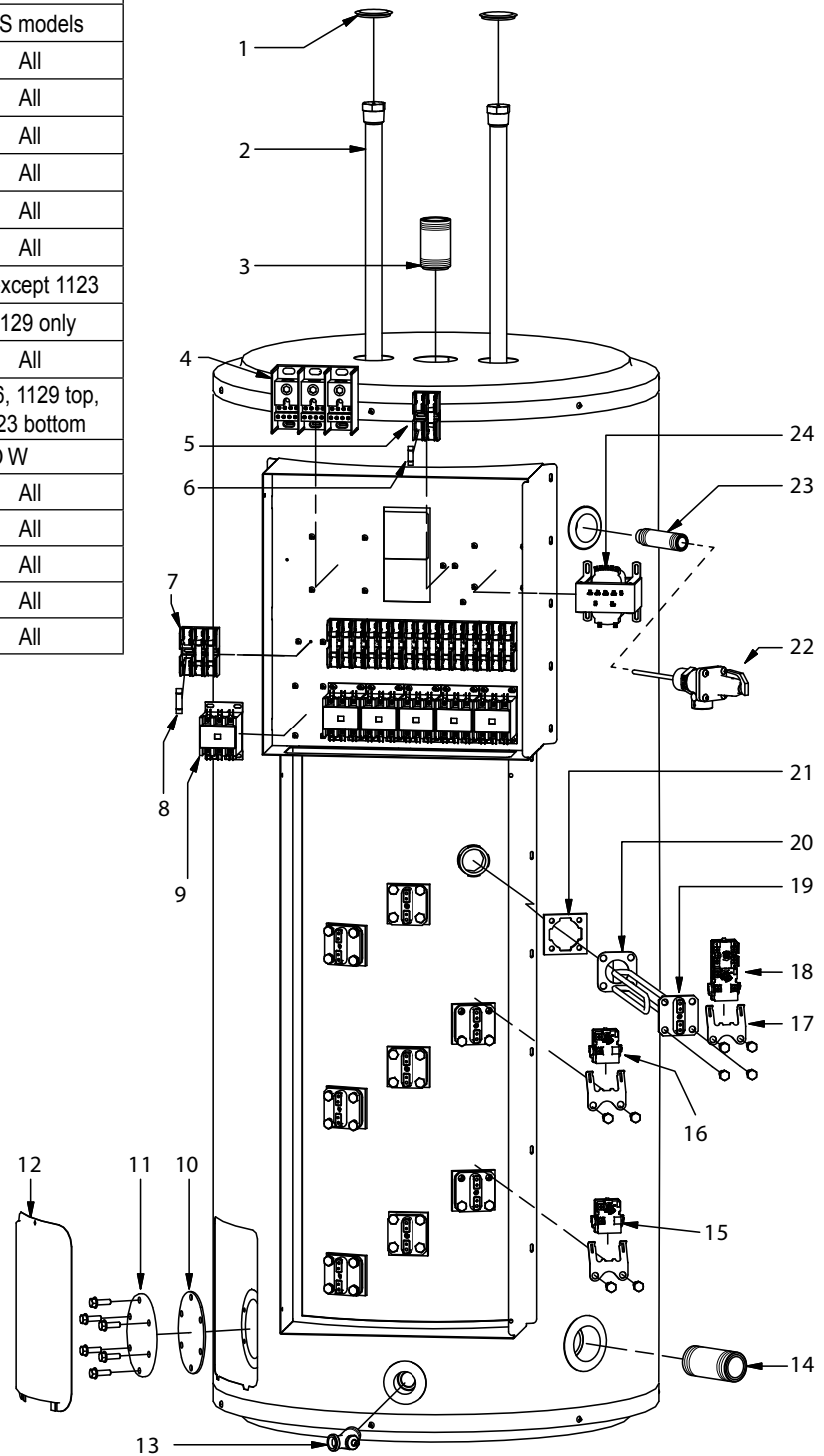

Illustration shows Model 112 with 9 elements

REPLACEMENT PARTS

Item	Part number	Description	Models
1	87000014-A	Snap-in plug	All
2	MS155410	Magnesium anodes	105
	MS155520		108
3	16000008-A	Outlet nipple 1½" X 3"	All
4	34001005-A	Fuse Holder (2P)	All
5	34000003-A	Fuses (3 amps Class G)	All
6	32000006-A	Terminal block three phases	All
7	CM586000	Contactors HCC-3XU02CY	All
8	99001204-A	Twist-lock flange with screws	All
9	18G0002	Square flange element gasket	All
10	SEE ELEMENT TABLE BELOW		
11	56000016-A	Combination thermostat / high limit	All except 1053,1083
	56000022-A	High limit	1053, 1083
12	GA1N1110	Clean-out gasket	All
13	25004111-A	Clean-out cover	All
14	99000061-A	Jacket door	All
15	18G0001	Thermostat bracket	All
16	DV3Z0070	Brass drain valve	All
17	56000018-A	Lower thermostat	1053, 1083
18	16001402-A	Inlet nipple 1½" X 4"	All
19	SV0N3020	T&P relief valve	All
20	16000015-A	Relief nipple ¾" X 3½"	All
21	TF485000	Transformer 600/240V	All

ELEMENT TABLE

Part #	Watts	Volts
12G20/80	2,000W	347V
12G30/80	3,000W	
12G40/80	4,000W	
12G45/80	4,500W	
12G50/90	5,000W	
12G60/100	6,000W	

600 Volts

105, 108 models
with 3, 6, or 9 elements

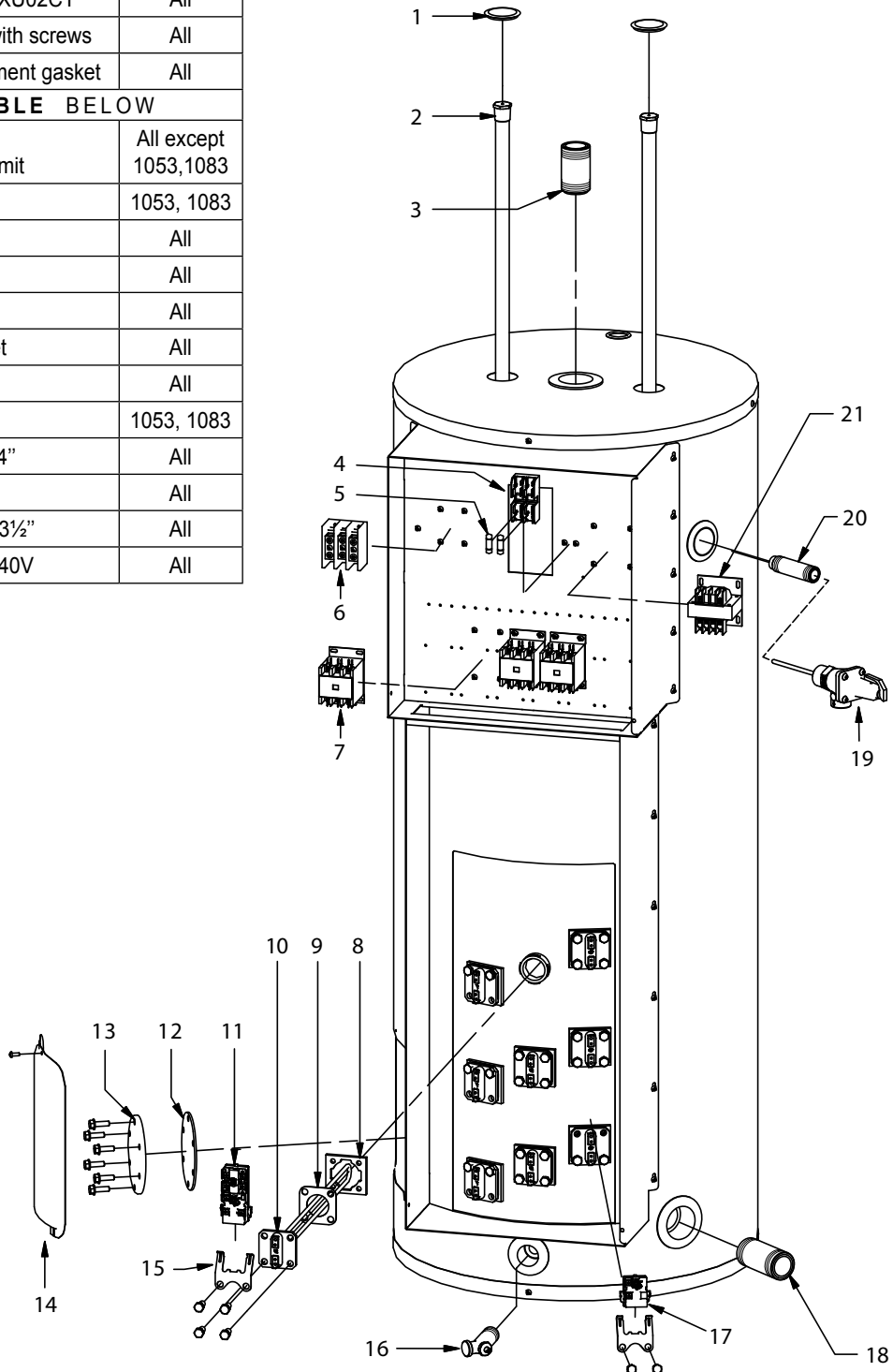

Illustration shows Model 108 with 9 elements

REPLACEMENT PARTS

Item	Part number	Description	Models
1	87000014-A	Snap-in plug	All
2	MS166530	Magnesium anodes	112
3	16000008-A	Outlet nipple 1½" X 3"	All
4	34001005-A	Fuse Holder (2P)	All
5	34000003-A	Fuses (3 amps Class G)	All
6	TB587000	Terminal block three phases	All
7	CU586000	Contactors HCC-3XU02CY	All
8	GA1N1110	Clean-out gasket	All
9	25004111-A	Clean-out cover	All
10	99000061-A	Jacket door	All
11	DV3Z0070	Brass drain valve	All
12	16001402-A	Inlet nipple 1½" X 4"	All
13	56000018-A	Lower thermostat	All except 1123
14	56000018-A	Middle thermostat	1129 only
15	18G0001	Thermostat bracket	All
16	56000016-A	Combination thermostat / high limit	1126, 1129 top 1123 bottom
17	SEE ELEMENT TABLE BELOW		
18	18G0002	Square flange element gasket	All
19	990012040A	Twist-Lock flange with screws	All
20	TF485000	Transformer 600/240V	All
21	SV0N3020	T&P relief valve	All except 63kW
22	16000015-A	Relief nipple ¾" X 3½"	63kW model only
23	17000017-A	T&P relief valve	63kW model only
24	90000006-A	Brass Tee 1½" X 1½" X 1"	63kW model only

ELEMENT TABLE

Part #	Watts	Volts
12G20/80	2,000W	347V
12G30/80	3,000W	
12G40/80	4,000W	
12G45/80	4,500W	
12G50/90	5,000W	
12G60/100	6,000W	
12G70/80	7,000W	

600 Volts

112 model with 3, 6, or 9 elements

112/600V at 63kW model

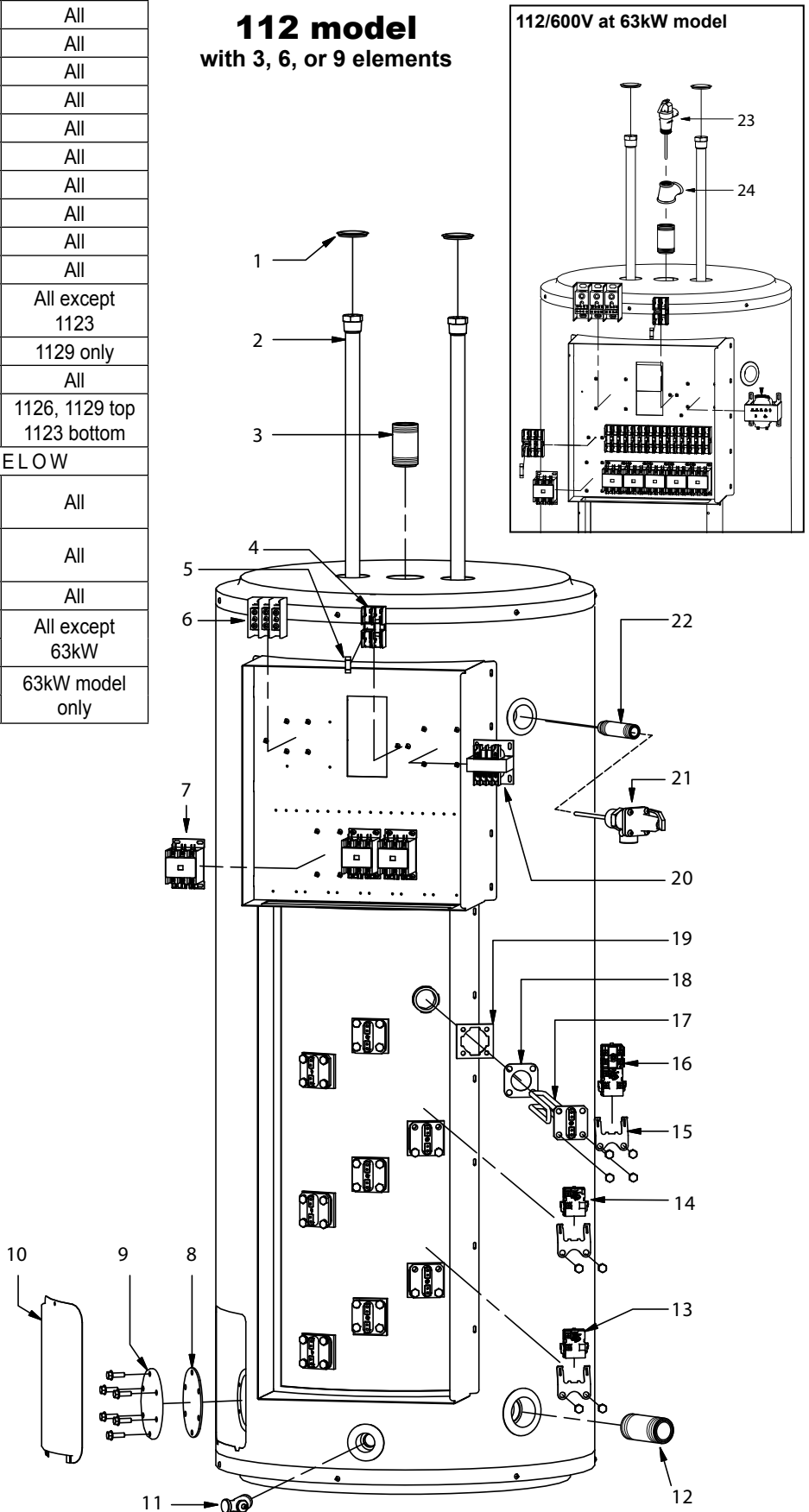

Illustration shows Model 112 with 9 elements

TROUBLESHOOTING GUIDE

CONDITION	CAUSE	REMEDY
No hot water.	Dry-fired element.	Replace with new element.
	Main power supply is "OFF".	Turn "ON" main power supply.
	Burnt fuse.	Replace with new fuse.
	Circuit breaker has tripped.	Reset circuit breaker.
	High limit reset control has tripped.	Reset high limit control by pushing the reset button.
	Circuit breaker is defective.	Replace with new circuit breaker.
	Defective thermostat.	Replace with new thermostat.
Not enough hot water.	Defective element.	Replace with new element.
	Water heater is undersized.	Install size of water heater that meets demand.
	High hot water demand.	Increase the temperature of the thermostat.
	Very cold water supply.	Increase the temperature of the thermostat.
	Wrong piping connections.	Correct piping.
	Sediment or lime accumulation at bottom of water heater.	Drain water heater. Check to see if water treatment is necessary.
	Hot water plumbing system leaks.	Check hot water plumbing system for leaks and repair.
	Thermostat adjusted too low.	Increase the temperature of the thermostat.
	Defective thermostat.	Replace with new thermostat.
	Defective element.	Replace with new element.
Boiling hot water.	Long runs or exposed piping.	Insulate piping.
	Hot water piping on outside wall.	Insulate piping.
	Thermostat temperature set too high.	Lower the temperature on the thermostat.
	Thermostat not in contact with water heater.	Position properly. Be sure insulation is not interfering with thermostat.
	Element attacked by CO ₂ .	Replace with new element.
Continuous operation.	Defective thermostat.	Replace with new thermostat.
	Water heater is undersized.	Install size of water heater that meets demand.
	Element wattage too small.	See Conversion Guide .
	Thermostat not in contact with water heater.	Position properly. Be sure insulation is not interfering with thermostat.
	Thermostat temperature set too low.	Increase the temperature of the thermostat.
	Defective thermostat.	Replace with new thermostat.
Element failure.	Defective high limit reset control.	Replace with new high limit reset control.
	Wiring connections are wrong.	See Figures 11 to 24 for correct wiring.
	Wiring connections are loose.	Locate, clean carefully, reconnect properly.
	Lightning/Power surge.	Inspect/replace fuse, element, and thermostat.
	High voltage.	Check with electrical utility and correct.
Thermostat failure.	Short circuit.	Locate short circuit and repair.
	No power.	Inspect fuse/circuit breaker, replace/reset.
	Loose wiring connection.	Locate, clean carefully, reconnect properly.
	Lightning/Power surge.	Inspect/replace fuse, element, and thermostat.
	Low/High voltage.	Check with electrical utility and correct.
Blown fuse/circuit breaker.	Short circuit.	Locate short circuit and repair.
	Power supply wiring undersized.	See Table 1 and consult electrical code for correct wire size.
	Wiring connections are wrong.	See Figures 11 to 24 for correct wiring.
	Wiring connections are loose.	Locate, clean carefully, reconnect properly.
	Lightning/Power surge.	Inspect/replace fuse, element, and thermostat.
	High voltage.	Check with electrical utility and correct.
Fuse burns instantly.	Short-circuit.	Locate short circuit and repair.
	Fuse contacts oxidized or fuse not screwed in tight enough.	Clean contacts and tighten fuse.
Fuse burns often.	Power supply wiring is undersized.	See Table 1 and consult electrical code for correct wire size.
CONDITION	CAUSE	REMEDY

TROUBLESHOOTING GUIDE

Smoking wiring.	Lightning/Power surge.	Inspect/replace fuse, element, and thermostat.
	Low/High voltage.	Check with electrical utility and correct.
	Power supply wiring undersized.	See Table 1 and consult electrical code for correct wire size.
Service wires charred or hot.	Wiring connections are wrong.	See Figures 11 to 24 for correct wiring.
	Water heater not properly grounded.	Properly ground the water heater.
	Lightning/Power surge.	Inspect/replace fuse, element, and thermostat.
	High voltage.	Check with electrical utility and correct.
	Short circuit.	Locate short circuit and repair.
	Power supply wiring undersized.	See Table 1 and consult electrical code for correct wire size.
Drain valve leaks.	Drain valve is open.	Close the drain valve.
	Defective drain valve.	Replace with new drain valve.
Water drips from the relief valve.	Excessive water pressure.	Install a pressure-reducing valve.
	Thermal expansion in a closed water system.	Install a suitable expansion tank on the cold water supply line.
	Improperly seated relief valve.	Check relief valve works properly and replace, if necessary.
	Defective thermostat.	Replace with new thermostat.
	Defective relief valve.	Replace with new relief valve.
Water on the floor/drain pan.	Water discharge from the relief valve.	See Pressure build-up in a water system.
	Element leaks.	Replace with new element and gasket.
	Water heater leaks.	Replace with new water heater.
Wet insulation.	Leaking plumbing connections.	Locate leak and repair.
	Leaking around heating element.	Tighten, clean, and smooth face of tank flange and replace element gasket.
	Water discharge from the relief valve.	See Pressure build-up in a water system.
Singing element.	Build up of mineral deposits on element.	Clean element, replace with new element if necessary.
Singing thermostat.	Thermostat not flush with tank.	Install thermostat properly.
	Wiring connections are loose.	Locate, clean carefully, reconnect properly.
Traces of rust in the hot water.	Anode rods has been eaten away.	Replace new anode rods.
Rusty water.	Water corrosion.	Replace with new water heater.
Rotten egg smell.	High sulfate or mineral content in water.	Change magnesium anodes to an aluminum anodes and bleach water heater.
Tank bulged.	No relief valve installed.	Install proper relief valve.
	Excessive water pressure.	Install a pressure-reducing valve.
	Thermal expansion in a closed water system.	Install a suitable expansion tank on the cold water supply line.
	“Water hammer”	Install anti-water hammers suitably selected and installed according to the manufacturer’s instructions

STANDARD BASIC LIMITED WARRANTY

ON COMMERCIAL WATER HEATERS, FLEXIBLE MODELS

(Hereunder referred to as "Unit" or "Equipment")

GENERAL

The manufacturer warrants that, subject to verification of your warranty claim within the warranty period described below, the necessary corrective actions will be taken to either repair or replace the defective unit or component part subject to the terms and conditions outlined in this document. Furthermore, any replacement unit or component part supplied under warranty will carry only the warranty remaining portion, based on the original unit installation date. However, the warranty is limited to ONE (1) replacement unit. If due to some unusual circumstance, a replacement unit or component part is found to be defective by our inspection department, another unit or component part will be provided in order to fulfill the obligation of the original warranty. This warranty applies only to the original owner that purchased the unit, to the unit original installation location, and it is not transferable. In order to benefit from this warranty, the warranty reply card must be completed and sent back to GIANT within forty-five (45) days of the unit purchase date, otherwise the warranty will be three (3) years from the date of manufacture, without exception.

THE INNER TANK

If the inner tank of a water heater leaks in the shortest period of THREE (3) years from the date of installation or FIFTY-FOUR (54) months from the date of manufacture, whichever comes first, a replacement will be provided to the original owner who purchased it. If an identical replacement model of the original model is not available, for any reason whatsoever, the manufacturer reserves the right to offer a comparable model, however, a surcharge will be applied for all component (s) which will have been incorporated into the water heater. Use of equipment for any purpose other than drinking water will void the warranty.

COMPONENT PARTS

If any component part is found to be defective within ONE (1) year from the date of original installation, provided said defective part is an in-house factory made piece or an original factory approved OEM piece, the manufacturer will furnish a replacement part after the receipt and testing of the part claimed to be defective.

THIS WARRANTY WILL NOT APPLY:

- 1) To defects or malfunctions resulting from failure to properly install, operate, or maintain the unit in accordance with the Owner's Manual.
- 2) If the installation does not conform to CSA &/or ETL Standards as well as any applicable national or local building codes.
- 3) To any damage or failure caused by abuse, fire, floods, freezing, or other acts of God.
- 4) To any damage or failure caused by operating the unit without an approved temperature & pressure-relief valve having been installed.
- 5) To any damage or failure caused by powering any energy source while the equipment is empty or partially empty or contains sediment build-up resulting in dry firing of the heating elements.

- 6) To any damage or failure caused by connecting the unit to any other source of energy not approved by GIANT or by operating the equipment for other use than with potable water without any additives such as salt, chlorine, or chemicals other than those added for the purpose of rendering the water fit to drink.

- 7) To any damage or failure caused by the removal of the anode and/or by not assuring that there is a working anode in the unit at all times. **"All anodes must be checked at least once every two (2) years & replaced, if necessary"**.

- 8) To any damage or failure caused by the use of the unit with a water softener if the magnesium anode has not been replaced by an aluminum anode approved by Giant, as well as the addition of zinc pellets.

- 9) To any damage or failure caused by having affixed to the unit any non-factory made or factory approved replacement part(s), such as elements, controls, dip-tubes, anode, induced-current anode, relief valves, etc.

- 10) To any damage caused by not having the unit installed adjacent to a free-flowing drain or in a pan or basin connected to such free-flowing drain.

- 11) For all equipment operated at water temperatures exceeding the maximum operating setting of the thermostat and/or the high limit control, at a pressure exceeding the one listed on the rating plate, for equipment subject to a water-hammer effect that reverses the bottom of the tank, units that are installed in a closed-looped system without any adequate expansion tank¹ being installed as well as equipment installed in a system equipped with a backflow preventer, a pressure-reducing valve, or any other device, such as a check valve, without an adequate expansion tank being installed.
 - i Or any other method accepted by the competent authority.

- 12) To any unit drained for wintering purposes.

- 13) To any performance issue caused by the poor selection of equipment, power supply, wiring, or fuse / breaker.

- 14) To any unit from which the rating plate has been removed or altered.

- 15) To any break or damage caused by a water-hammer effect coming from, but not limited to, a quick-closing valve, a solenoid valve, or any other valves without an adequate pre-fabricated expansion tank being installed in compliance with existing codes, standards, and good practices.

- 16) To any issue caused by the installation of water connections not compatible with the equipment input and output "NPT" connections.

- 17) To any unit installed outside of Canada or the United States.

SERVICE LABOUR RESPONSIBILITY

This warranty does not cover any labour expense for diagnostic, service, removal, or re-installation of a replacement unit. All such expenses are the responsibility of the unit owner.

SHIPPING COSTS

If a unit or component part is deemed to be replaced, the manufacturer will pay the transportation costs to ship said replacement unit or part to a convenient authorized distributor or retailer of our choice. The unit owner must pay for any local cartage including the cost of returning the replaced unit or component part to the authorized distributor or retailer.

CLAIM PROCEDURE

Any claim covered by the warranty must be made to GIANT within a maximum of thirty (30) days from the date the defect is first discovered. Failure to provide a written notice for such defect to the manufacturer within the allocated time frame will void the warranty. Any claim for warranty service should be made with your contractor, wholesaler, or retailer from whom the unit was purchased. In turn, said contractor, wholesaler, or retailer will contact the manufacturer. If this procedure cannot be followed, please contact a local contractor, wholesaler, or retailer distributing our products. For further warranty information, please call our customer service department at (514) 645-8893 or 1-800-363-9354, option 1. In order to answer your call promptly, prior to calling the factory, please make sure to have handy the unit model and serial number that is found on the rating plate, on the side of the unit. Proof of purchase showing the date and name of the business from whom the unit was purchased is mandatory if the manufacturing date goes beyond the warranty period offered by the manufacturer.

If an exact replacement unit is unavailable for whatever reason such as, but not limited to, changes in government standards, the manufacturer agrees to provide a unit or component part with comparable features. If government regulations or industry standards require the replacement unit or component part to have features not found on the defective unit or component part, the unit owner will be charged the difference in price associated with these required features. If such owner pays the difference in price for these required features, they will benefit from a complete new Standard Basic Limited Warranty for the replacement unit.

MISCELLANEOUS

No one is authorized to modify any conditions of this actual warranty. The manufacturer will not honour any other warranty of any kind other than what is offered. No claims for incidental or consequential damage (including damage from leakage) will be accepted. If the warranty card is not returned to us, a proof of purchase showing the name, date, and location of the original point of purchase is mandatory to process any warranty claim. Failure to provide such documentation will result in the lesser of the warranty periods being offered, as stated in the "GENERAL" section. **In order to avoid any confusion and/or disputes, we suggest that the warranty card be completed and returned to us no later than forty-five (45) days after installation.**