



Enhancing everyday living



ENGINEERING SUBMITTAL DATA SHEET

Energy Efficient Light Duty Commercial
Power Vent Water Heater

UG75 MODEL

63 imperial gallons / 284 Litres

insulated with 2" eco-friendly **GREENFOAM**

This model meets all safety and construction requirements of CSA 4.3 Standard and meets or exceeds the thermal efficiency and standby loss requirements of current ASHRAE 90.1 Standard.

Model	Storage Capacity			Type of gas	Input BTU	Recovery 90 °F / 50 °C			Altitude	Est. ship. weight lb (kg)
	(US) gal	Litres	Imp. gal			(US) gal	Litres	Imp. gal		
UG75-76MEPV1-N2U-RE	75	284	63	N	76,000	82.9	313.8	69	0 - 7,800	301.1 (136.6)

DIMENSIONS inches (cm)

Model	A	B	C	D	E	E1	E2	F	G	H	I	J	K	L	M
UG75	11 ¼ (29)	52 7/8 (134)	62 ½ (159)	16 ¼ (41)	64 ½ (163)	18 5/8 (47)	54 ½ (137)	72 ¾ (184)	11 (28)	26 (66)	3 - 4* (7.6 - 10.2)	55.8°	63.6°	4 ¾ (12)	2 ¾ (7)

*Refer to installation manual

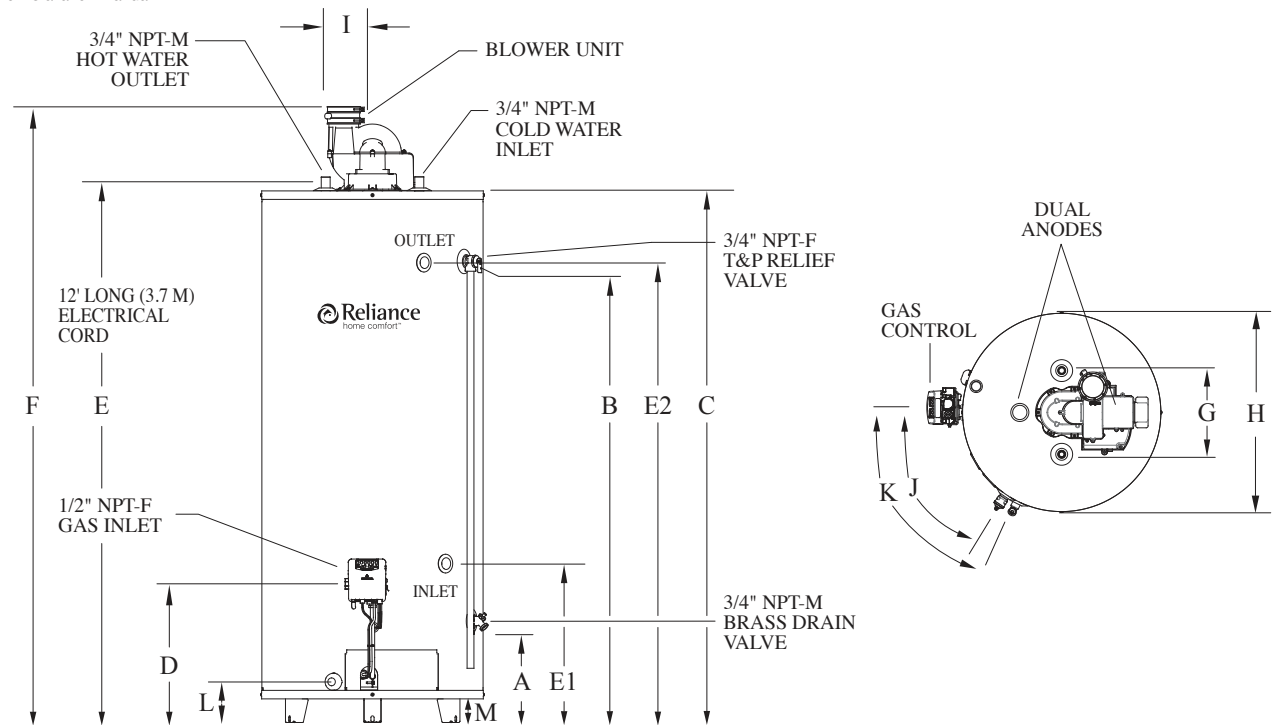

JOB TITLE

SUBMITTED DATE

ADDRESS

REQUIRED PRODUCT

CONTRACTOR

MODEL NO. SIZE QUANTITY

ADDRESS

MODEL NO. SIZE QUANTITY

ENGINEER

MODEL NO. SIZE QUANTITY

MODEL NO. SIZE QUANTITY

REQUIRED DATE

In accordance with our company policy of on-going product improvement, Giant Factories Inc. reserves the right to make changes without prior notice.

giantinc.com



40 Lesage Avenue, Montréal-East (Québec) Canada H1B 5H3 • Telephone: 514-645-8893 • Fax: 514-640-0969